

# Demonstration System EPC9113 Quick Start Guide

*6.78 MHz, ZVS Class-D Wireless Power System  
using EPC2108 / EPC2036*



**DESCRIPTION**

The EPC9113 wireless power demonstration system is a high efficiency, Zero Voltage Switching (ZVS), Voltage Mode class-D wireless power transfer demonstration kit capable of delivering up to 16 W into a DC load while operating at 6.78 MHz (Lowest ISM band). The purpose of this demonstration system is to simplify the evaluation process of wireless power technology using eGaN® FETs and ICs.

The EPC9113 wireless power system comprises the three boards (shown in Figure 1) namely:

- 1) A Source Board (Transmitter or Power Amplifier) EPC9509
- 2) A Class 3 AirFuel™ Alliance compliant Source Coil (Transmit Coil)
- 3) A Category 3 AirFuel compliant Device Coil with rectifier and DC smoothing capacitor.

The amplifier board features the enhancement-mode, half-bridge field effect transistor (FET), the 60 V rated EPC2108 eGaN FET with integrated synchronous bootstrap FET. The amplifier can be set to operate in either differential mode or single-ended mode and includes the gate driver/s, oscillator, and feedback controller for the pre-regulator that ensures operation for wireless power control based on the AirFuel standard. This allows for testing compliant to the AirFuel class 3 standard over a load range as high as  $\pm 50j \Omega$ . The pre-regulator features the 100 V rated 73 m $\Omega$  EPC2036 as the main switching device for a SEPIC converter.

The EPC9509 can operate in either Single ended or Differential mode by changing a jumper setting. This allows for high efficiency operation with load impedance ranges that allow for single ended operation.

The timing, the timing adjust circuits for the ZVS class-D amplifiers have been separated to further ensure highest possible efficiency setting and includes separate ZVS tank circuits.

The amplifier is equipped with a pre-regulator controller that adjusts the voltage supplied to the ZVS Class-D amplifier based on the limits of 3

parameters; coil current, DC power delivered, and maximum voltage. the coil current has the lowest priority followed by the power delivered with amplifier supply voltage having the highest priority. Changes in the device load power demand, physical placement of the device on the source coil and other factors such as metal objects in proximity to the source coil all contribute to variations in coil current, DC power, and amplifier voltage requirements. Under any conditions, the controller will ensure the correct operating conditions for the ZVS class-D amplifier based on the AirFuel standard. The pre-regulator can be bypassed to allow testing with custom control hardware. The board further allows easy access to critical measurement nodes that allow accurate power measurement instrumentation hookup. A simplified diagram of the amplifier board is given in Figure 2.

The Source and Device Coils are AirFuel Alliance compliant and have been pre-tuned to operate at 6.78 MHz with the EPC9509 amplifier. The source coil is class 3 and the device coil is category 3 compliant.

The device board includes a high frequency schottky diode based full bridge rectifier and output filter to deliver a filtered unregulated DC voltage. The device board comes equipped with two LED's, one green to indicate the power is being received with an output voltage equal or greater than 4 V and a second red LED that indicates that the output voltage has reached the maximum and is above 37 V.

For more information on the EPC2108 or EPC2036 please refer to the datasheet available from EPC at [www.epc-co.com](http://www.epc-co.com). The datasheet should be read in conjunction with this quick start guide.

The Source coil used in this wireless power transfer demo system is provided by NuCurrent ([nucurrent.com](http://nucurrent.com)). Reverse Engineering of the Source coil is prohibited and protected by multiple US and international patents. For additional information on the source coil, please contact NuCurrent direct or EPC for contact information.

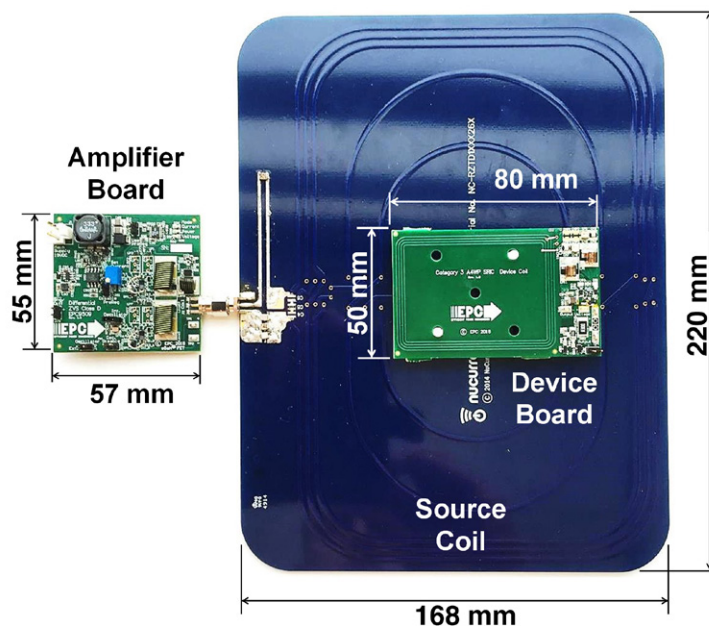

Figure 1: EPC9113 demonstration system.

**Table 1: Performance Summary (T<sub>A</sub> = 25°C) EPC9509**

Symbol	Parameter	Conditions	Min	Max	Units
V <sub>IN</sub>	Bus Input Voltage Range – Pre-Regulator Mode	Also used in bypass mode for logic supply	17	24	V
V <sub>IN</sub>	Amp Input Voltage Range – Bypass Mode		0	52	V
V <sub>OUT</sub>	Switch-Node Output Voltage			52	V
I <sub>OUT</sub>	Switch-Node Output Current (each)			1*	A
V <sub>extosc</sub>	External Oscillator Input Threshold	Input 'Low'	-0.3	0.8	V
		Input 'High'	2.4	5	V
V <sub>Pre_Disable</sub>	Pre-Regulator Disable Voltage Range	Floating	-0.3	5.5	V
I <sub>Pre_Disable</sub>	Pre-Regulator Disable Current	Floating	-10	10	mA
V <sub>Osc_Disable</sub>	Oscillator Disable Voltage Range	Open Drain/Collector	-0.3	5	V
I <sub>Osc_Disable</sub>	Oscillator Disable Current	Open Drain/Collector	-25	25	mA
V <sub>sgnDiff</sub>	Differential or Single-Select Voltage	Open Drain/Collector	-0.3	5.5	V
I <sub>sgnDiff</sub>	Differential or Single-Select Current	Open Drain/Collector	-1	1	mA

\*Maximum current depends on die temperature – actual maximum current will be subject to switching frequency, bus voltage and thermal.

**Table 2: Performance Summary (T<sub>A</sub> = 25 °C) Category 3 Device Board**

Symbol	Parameter	Conditions	Min	Max	Units
V <sub>OUT</sub>	Output Voltage Range		0	38	V
I <sub>OUT</sub>	Output Current Range		0	1.5#	A

# Actual maximum current subject to operating temperature limits

## MECHANICAL ASSEMBLY

The assembly of the EPC9113 Wireless Demonstration kit is simple and shown in Figure 1. The source coil and amplifier have been equipped with SMA connectors. The source coil is simply connected to the amplifier.

The device board does not need to be mechanically attached to the source coil.

The coil sets of the EPC9111 and EPC9112 (both the source and device coils) are not compatible with the EPC9113/4 kit. To prevent inadvertent connection of either, the connectors of the amplifier and coils have been changed from reverse polarity to standard polarity. Please contact EPC for modifications to the original coil set to ensure compatibility with the EPC9509 amplifier.

## DETAILED DESCRIPTION

### The Amplifier Board (EPC9509)

Figure 2 shows the system block diagram of the EPC9509 ZVS class-D amplifier with pre-regulator and Figure 3 shows the details of the ZVS class-D amplifier section. The pre-regulator is used to control the ZVS class-D wireless power amplifier based on three feedback parameters 1) the magnitude of the coil current indicated by the green LED, 2) the DC power drawn by the amplifier indicated by

the yellow LED and 3) a maximum supply voltage to the amplifier indicated by the red LED. Only one parameter at any time is used to control the pre-regulator with the highest priority being the maximum voltage supplied to the amplifier followed by the power delivered to the amplifier and lastly the magnitude of the coil current. The maximum amplifier supply voltage is pre-set to 52 V and the maximum power drawn by the amplifier is pre-set to 16 W. The coil current magnitude is pre-set to 800 mA<sub>RMS</sub> but can be made adjustable using P25. The pre-regulator comprises a SEPIC converter that can operate at full power from 17 V through 24 V.

The pre-regulator can be bypassed by connecting the positive supply directly to the ZVS class-D amplifier supply after removing the jumper at location JP1 and connecting the main positive supply to the bottom pin. JP1 can also be removed and replaced with a DC ammeter to directly measure the current drawn by the amplifier. When doing this observe a low impedance connection to ensure continued stable operation of the controller. Together with the Kelvin voltage probes (TP1 and TP2) connected to the amplifier supply, an accurate measurement of the power drawn by the amplifier can be made.

The EPC9509 is also provided with a miniature high efficiency switch-mode 5 V supply to power the logic circuits on board such as the gate drivers and oscillator.

The amplifier comes with its own low supply current oscillator that is pre-programmed to 6.78 MHz ± 678 Hz. It can be disabled by placing a jumper into JP70 or can be externally shutdown using an externally controlled open collector / drain transistor on the terminals of JP70 (note which is the ground connection). The switch needs to be capable of sinking at least 25 mA. An external oscillator can be used instead of the internal oscillator when connected to J70 (note which is the ground connection) and the jumper (JP71) is removed.

The pre-regulator can also be disabled in a similar manner as the oscillator using JP50. However, note that this connection is floating with respect to the ground so removing the jumper for external connection requires a floating switch to correctly control this function. Refer to the datasheet of the controller IC and the schematic in this QSG for specific details.

The ZVS timing adjust circuits for the ZVS class D amplifiers are each independently settable to ensure highest possible efficiency setting and includes separate ZVS tank circuits. This allows OOK modulation capability for the amplifier.

The EPC9509 is provided with 3 LED's that indicate the mode of operation of the system. If the system is operating in coil current limit mode, then the green LED will illuminate. For power limit mode, the yellow LED will illuminate. Finally, when the pre-regulator reaches maximum output voltage the red LED will illuminate indicating that the system is no longer AirFuel compliant as the load impedance is too high for the amplifier to drive. When the load impedance is too high to reach power limit or voltage limit mode, then the current limit LED will illuminate incorrectly indicating current limit mode. This mode also falls outside the AirFuel standard and by measuring the amplifier supply voltage across TP1 and TP2 will show that it has nearly reach the maximum value limit.

**Single ended or Differential Mode operation**

The EPC9509 amplifier can be operated in one of two modes; single-ended or differential mode. Single ended operation offers higher amplifier efficiency but reduced imaginary impedance drive capability. If the reflected impedance of the tuned coil load exceeds the capability of the amplifier to deliver the desired power, then the amplifier can be switched over to differential mode. In differential mode, the amplifier is capable of driving an impedance range of 1 Ω through 56 Ω and ±50j Ω and maintains either the 800 mA<sub>RMS</sub> coil current or deliver up to 16 W of power. The EPC9509 is set by default to differential mode and can be switched to single ended mode by inserting a jumper into J75. When inserted the amplifier operates in the single-ended mode. Using an external pull down with floating collector/ drain connection will have the same effect. The external transistor must be capable of sinking 25 mA and withstand at least 6 V."

For differential mode only operation, the two ZVS inductors L<sub>ZVS1</sub> and L<sub>ZVS2</sub> can be replaced by a single inductor L<sub>ZVS12</sub> and by removing C<sub>ZVS1</sub> and C<sub>ZVS2</sub>.

**ZVS Timing Adjustment**

Setting the correct time to establish ZVS transitions is critical to achieving high efficiency with the EPC9509 amplifier. This can be done by selecting the values for R71, R72, R77, and R78 or P71, P72, P77, and P78 respectively. This procedure is best performed using a potentiometer installed at the appropriate locations that is used to determine the fixed resistor values. The procedure is the same for both single-ended and differential mode of operation. The timing MUST initially be set WITHOUT the source coil connected to the amplifier. The timing diagrams are given in Figure 10 and should be referenced when following this procedure. Only perform these steps if changes have been made to the board as it is shipped preset. The steps are:

1. With power off, remove the jumper in JP1 and install it into JP50 to place the EPC9509 amplifier into Bypass mode. Connect the main input power supply (+) to JP1 (bottom pin – for bypass mode) with ground connected to J1 ground (-) connection.
2. With power off, connect the control\_input power supply bus (19 V) to (+) connector (J1). Note the polarity of the supply connector.
3. Connect a LOW capacitance oscilloscope probe to the probe-hole of the half-bridge to be set and lean against the ground post as shown in Figure 9.
4. Turn on the control supply – make sure the supply is approximately 19 V.
5. Turn on the main supply voltage starting at 0 V and increasing to the required predominant operating value (such as 24 V but NEVER exceed the absolute maximum voltage of 52 V).
6. While observing the oscilloscope adjust the applicable potentiometers to so achieve the green waveform of Figure 10.
7. Repeat for the other half-bridge.
8. Replace the potentiometers with fixed value resistors if required Remove the jumper from JP50 and install it back into JP1 to revert the EPC9509 back to pre-regulator mode.

**Determining component values for L<sub>ZVS</sub>**

The ZVS tank circuit is not operated at resonance, and only provides the necessary negative device current for self-commutation of the output voltage at turn off. The capacitors C<sub>ZVS1</sub> and C<sub>ZVS2</sub> are chosen to have a very small ripple voltage component and are typically around 1 μF. The amplifier supply voltage, switch-node transition time will determine the value of inductance for L<sub>ZVSx</sub>, which needs to be sufficient to maintain ZVS operation over the DC device load resistance range and coupling between the device and source coil range and can be calculated using the following equation:

$$L_{ZVS} = \frac{\Delta t_{vt}}{8 \cdot f_{sw} \cdot C_{OSSQ} + C_{well}} \tag{1}$$

**Where:**

- Δt<sub>vt</sub> = Voltage Transition Time [s]
- f<sub>sw</sub> = Operating Frequency [Hz]
- C<sub>OSSQ</sub> = Charge Equivalent Device Output Capacitance [F]
- C<sub>well</sub> = Gate driver well capacitance [F]. Use 20 pF for the LM5113

**NOTE.** that the amplifier supply voltage V<sub>AMP</sub> is absent from the equation as it is accounted for by the voltage transition time. The C<sub>OSS</sub> of the EPC2108 eGaN FETs is very low and lower than the gate driver well capacitance C<sub>well</sub> which as a result must now be included in the ZVS timing calculation. The charge equivalent capacitance can be determined using the following equation:

$$C_{OSSQ} = \frac{1}{V_{AMP}} \cdot \int_0^{V_{AMP}} C_{OSS}(v) \cdot dv \tag{2}$$

To add additional immunity margin for shifts in coil impedance, the value of L<sub>ZVS</sub> can be decreased to increase the current at turn off of the devices (which will increase device losses). Typical voltage transition times range from 2 ns through 12 ns. For the differential case the voltage and charge (C<sub>OSSQ</sub>) are doubled when calculating the ZVS inductance.

**The Source Coil**

Figure 4 shows the schematic for the source coil which is Class 3 AirFuel compliant. The matching network includes both series and shunt tuning. The matching network series tuning is differential to allow balanced connection and voltage reduction for the capacitors.

**The Device Board**

Figure 5 shows the basic schematic for the device coil which is Category 3 AirFuel compliant. The matching network includes both series and shunt tuning. The matching network series tuning is differential to allow balanced connection and voltage reduction for the capacitors.

The device board comes equipped with a kelvin connected output DC voltage measurement terminal and a built in shunt to measure the output DC current.

Two LEDs have been provided to indicate that the board is receiving power with an output voltage greater than 4 V (green LED) and that the board output voltage limit has been reached (greater than 36 V using the red LED).

## QUICK START PROCEDURE

The EPC9113 demonstration system is easy to set up and evaluate the performance of the eGaN FET in a wireless power transfer application. Refer to Figure 1 to assemble the system and Figures 6 and 8 for proper connection and measurement setup before following the testing procedures.

The EPC9509 can be operated using any one of two alternative methods:

- a. Using the pre-regulator
- b. Bypassing the pre-regulator

### **a. Operation using the pre-regulator**

The pre-regulator is used to supply power to the amplifier in this mode and will limit the coil current, power delivered or maximum supply voltage to the amplifier based on the pre-determined settings.

The main 19 V supply must be capable of delivering 2 ADC. DO NOT turn up the voltage of this supply when instructed to power up the board, instead simply turn on the supply. The EPC9509 board includes a pre-regulator to ensure proper operation of the board including start up.

1. Make sure the entire system is fully assembled prior to making electrical connections and make sure jumper JP1 is installed. Also make sure the source coil and device coil with load are connected.
2. With power off, connect the main input power supply bus to J1 as shown in Figure 3. Note the polarity of the supply connector.
3. Make sure all instrumentation is connected to the system.
4. Turn on the main supply voltage to the required value (19 V)
5. Once operation has been confirmed, observe the output voltage and other parameters on both the amplifier and device boards.
6. For shutdown, please follow steps in the reverse order.

### **b. Operation bypassing the pre-regulator**

In this mode, the pre-regulator is bypassed and the main power is connected directly to the amplifier. This allows the amplifier to be operated using an external regulator.

*In this mode there is no protection for ensuring the correct operating conditions for the eGaN FETs.*

1. Make sure the entire system is fully assembled prior to making electrical connections and make sure jumper JP1 has been removed and installed in JP50 to disable the pre-regulator and to place the EPC9509 amplifier in bypass mode. Also make sure the source coil and device coil with load are connected.
2. With power off, connect the main input power supply bus +V<sub>IN</sub> to the bottom pin of JP1 and the ground to the ground connection of J1 as shown in Figure 3.
3. With power off, connect the control input power supply bus to J1. Note the polarity of the supply connector. This is used to power the gate drivers and logic circuits.
4. Make sure all instrumentation is connected to the system.
5. Turn on the control supply – make sure the supply is 19 V range.
6. Turn on the main supply voltage to the required value (it is recommended to start at 0 V and do not exceed the absolute maximum voltage of 52 V).

7. Once operation has been confirmed, adjust the main supply voltage within the operating range and observe the output voltage, efficiency and other parameters on both the amplifier and device boards.
8. For shutdown, please follow steps in the reverse order. Start by reducing the main supply voltage to 0 V followed by steps 6 through 2.

#### **NOTE.**

1. When measuring the high frequency content switch-node (Source Coil Voltage), care must be taken to avoid long ground leads. An oscilloscope probe connection (preferred method) has been built into the board to simplify the measurement of the Source Coil voltage (shown in Figure 4).
2. To maintain control stability, the red LED for voltage mode indicator on the EPC9509 version 1.0 has been disabled. This will be corrected in subsequent revisions of the board. For questions regarding this LED function, please contact EPC.
3. AVOID using a Lab Benchtop programmable DC as the load for the category 3 device board. These loads have low control bandwidth and will cause the EPC9113 system to oscillate at a low frequency and may lead to failure. It is recommended to use a fixed low inductance resistor as an initial load. Once a design matures, a post regulator, such as a Buck converter, can be used.

## THERMAL CONSIDERATIONS

The EPC9113 demonstration system showcases the EPC2108 and EPC2036 in a wireless energy transfer application. Although the electrical performance surpasses that of traditional silicon devices, their relatively smaller size does magnify the thermal management requirements. The operator must observe the temperature of the gate driver and eGaN FETs to ensure that both are operating within the thermal limits as per the datasheets.

**NOTE.** The EPC9113 demonstration system has limited current and thermal protection only when operating off the Pre-Regulator. When bypassing the pre-regulator there is no current or thermal protection on board and care must be exercised not to over-current or over-temperature the devices. Excessively wide coil coupling and load range variations can lead to increased losses in the devices.

### **Pre-Cautions**

The EPC9113 demonstration system has no enhanced protection systems and therefore should be operated with caution. Some specific precautions are:

1. Never operate the EPC9113 system with a device board that is AirFuel compliant as this system does not communicate with the device to correctly setup the required operating conditions and doing so can lead to the failure of the device board. Please contact EPC should operating the system with an AirFuel compliant device is required to obtain instructions on how to do this. Please contact EPC at info@epc-co.com should the tuning of the coil be required to change to suite specific conditions so that it can be correctly adjusted for use with the ZVS class-D amplifier.
2. There is no heat-sink on the devices and during experimental evaluation it is possible present conditions to the amplifier that may cause the devices to overheat. Always check operating conditions and monitor the temperature of the EPC devices using an IR camera.
3. Never connect the EPC9509 amplifier board into your VNA in an attempt to measure the output impedance of the amplifier. Doing so will severely damage the VNA.

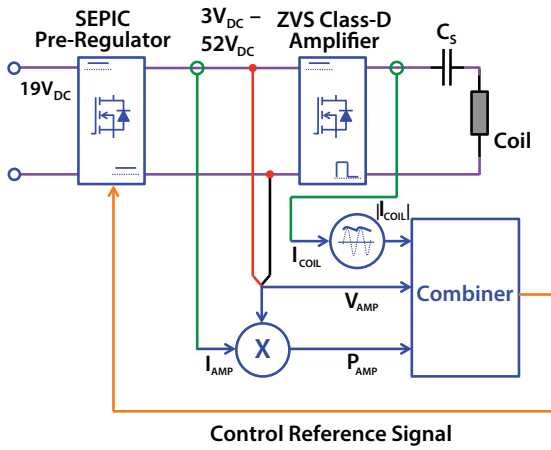

Figure 2: Block diagram of the EPC9509 wireless power amplifier.

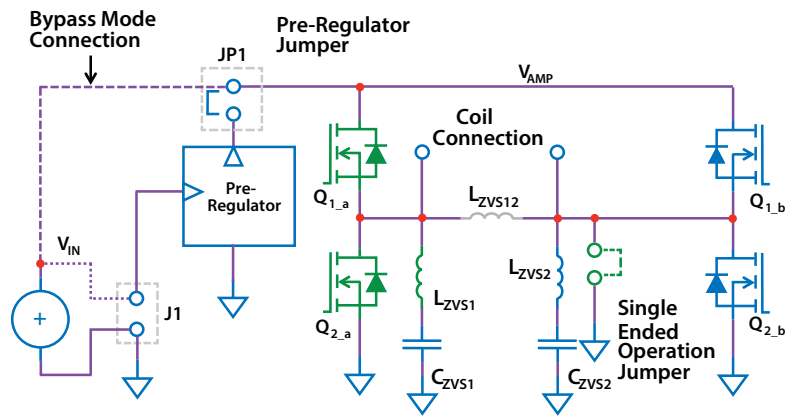

Figure 3: Diagram of EPC9509 amplifier circuit.

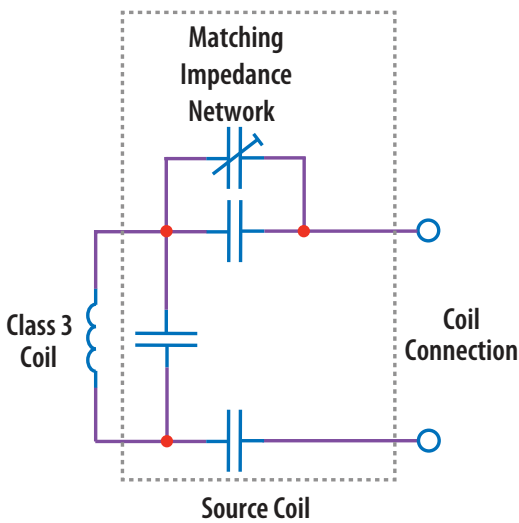

Figure 4: Basic schematic of the AirFuel Class 3 source coil.

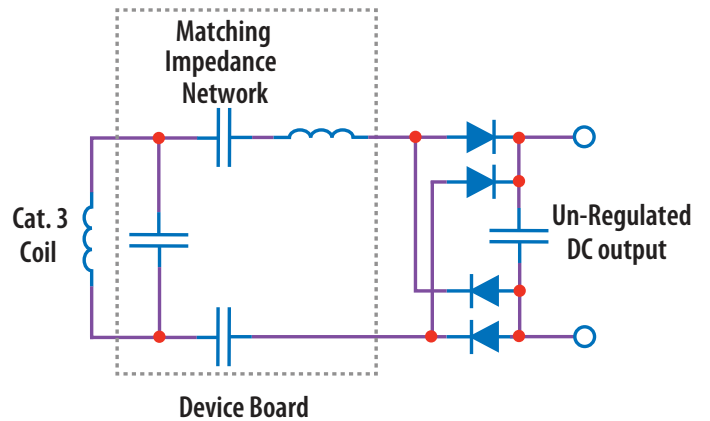

Figure 5: Basic schematic of the AirFuel Category 3 device board.

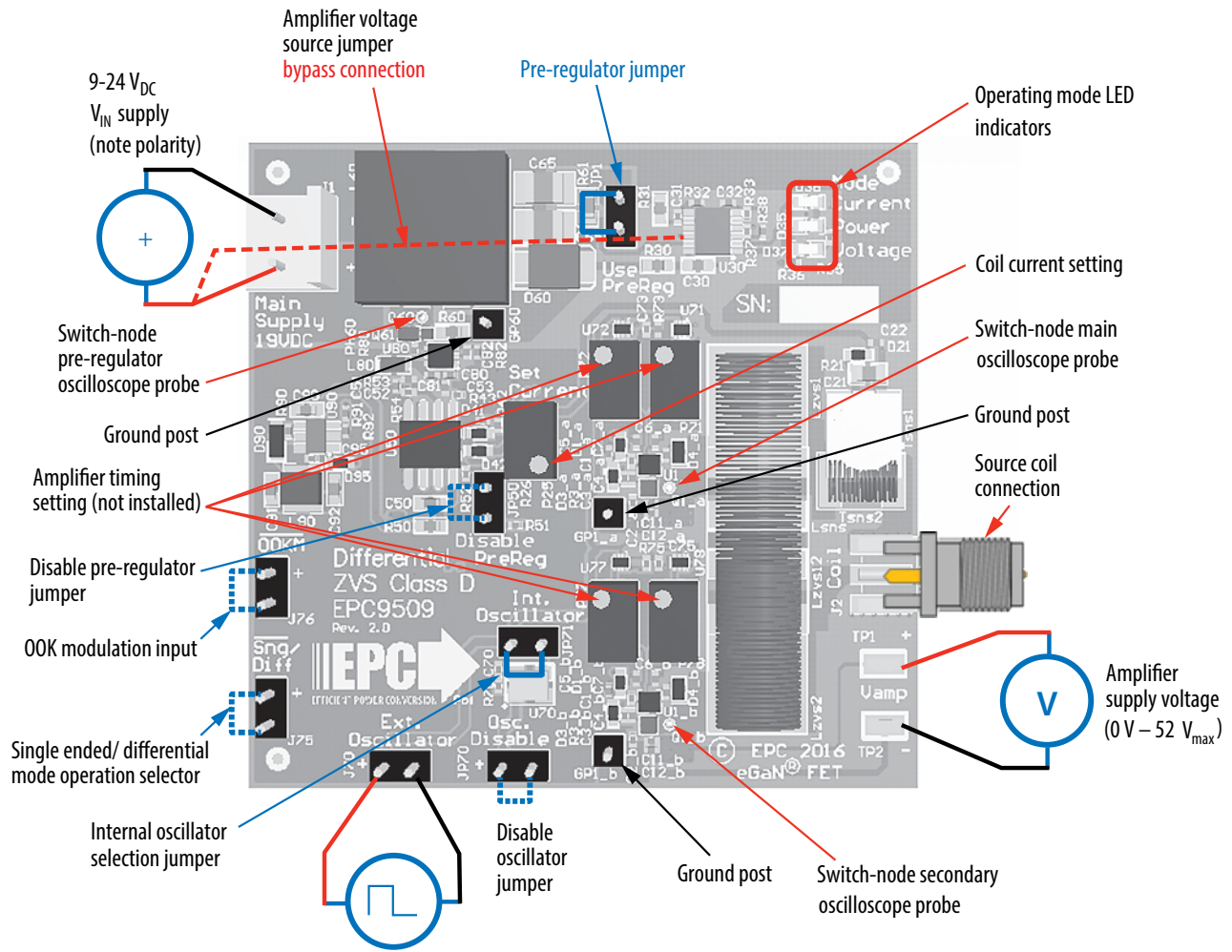

Figure 6: Proper connection and measurement setup for the amplifier board.

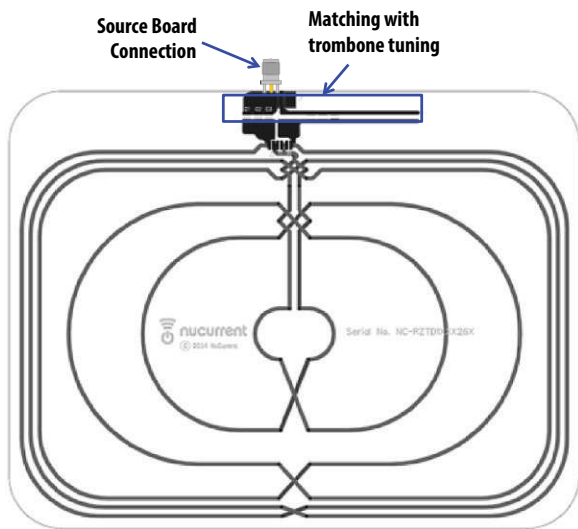

Figure 7: Proper connection for the source coil.

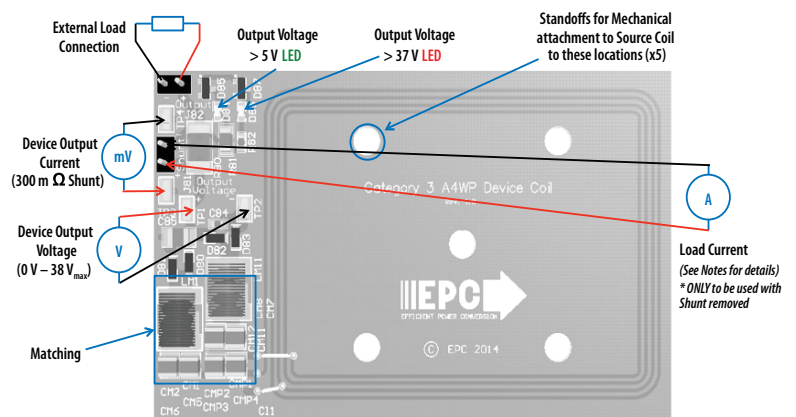

Figure 8: Proper connection and measurement setup for the device board.

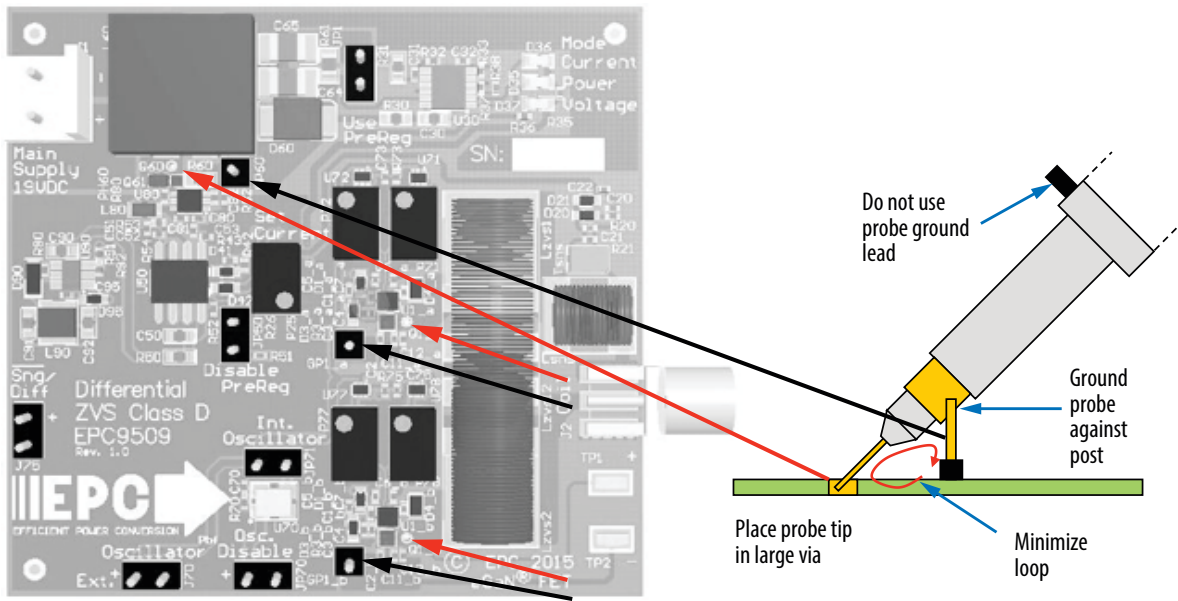

Figure 9 : Proper measurement of the switch nodes using the hole and ground post.

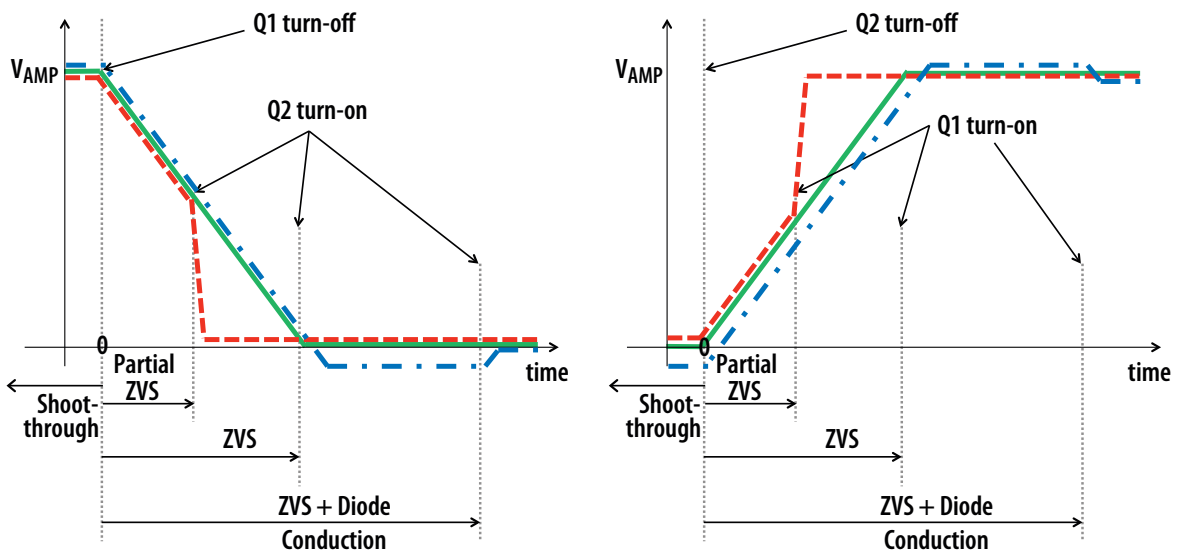

Figure 10: ZVS timing diagrams.



**Table 3: Bill of Materials - Amplifier Board**

Item	Qty	Reference	Part Description	Manufacturer	Part #
1	3	C1_a, C1_b, C80	1 $\mu$ F, 10 V	TDK	C1005X7S1A105M050BC
2	12	C2_a, C2_b, C4_a, C4_b, C35, C51, C70, C71, C72, C77, C78, C81	100 nF, 16 V	Würth	885012205037
3	3	C3_a, C3_b, C95	22 nF, 25 V	Würth	885012205052
4	2	C5_a, C5_b	DNP (100 nF, 16 V)	Würth	885012205037
5	1	C20	DNP (1 nF, 50 V)	Murata	GRM155R71H102KA01D
6	1	C73	DNP (22 pF, 50 V)	Würth	885012005057
7	1	R20	DNP (10k)	Panasonic	ERJ-2GEJ103X
8	8	C6_a, C6_b, C7_a, C7_b, C31, C44, C75, C82	22 pF, 50 V	Würth	885012005057
9	4	C11_a, C11_b, C12_a, C12_b	10 nF, 100 V	TDK	C1005X7S2A103K050BB
10	4	C15_a, C15_b, C64, C65	2.2 $\mu$ F, 100 V	Taiyo Yuden	HMK325B7225KN-T
11	1	C21	680 pF, 50 V	Murata	GRM155R71H681KA01D
12	1	C22	1 nF, 50 V	Murata	GRM155R71H102KA01D
13	2	C30, C50	100 nF, 100 V	Murata	GRM188R72A104KA35D
14	1	C32	1 nF, 50 V	Murata	GRM1555C1H102JA01D
15	1	C52	100 pF	Murata	GRM1555C1H101JA01D
16	2	C53, CR43 (on top of R43)	10 nF, 50 V	Murata	GRM155R71H103KA88D
17	2	C61, C62	4.7 $\mu$ F, 50 V	Taiyo Yuden	UMK325BJ475MM-T
18	1	C63	10 $\mu$ F, 35 V	Taiyo Yuden	GMK325BJ106KN-T
19	3	C90, C91, C92	1 $\mu$ F, 25 V	Würth	885012206076
20	2	C <sub>zvs1r</sub> , C <sub>zvs2</sub>	1 $\mu$ F, 50 V	Würth	885012207103
21	3	D1_a, D1_b, D95	40 V, 300 mA	ST	BAT54KFILM
22	10	D2_a, D2_b, D21, D40, D41, D42, D71, D72, D77, D78	40 V, 30 mA	Diodes Inc.	SDM03U40
23	3	D3_a, D3_b, D20	40 V, 30 mA	Diodes Inc.	SDM03U40
24	2	D4_a, D4_b	5V1, 150 mW	Bournes	CD0603-Z5V1
25	1	D35	LED 0603 Yellow	Lite-On	LTST-C193KSKT-5A
26	1	D36	LED 0603 Green	Lite-On	LTST-C193KGKT-5A
27	1	D37	LED 0603 Red	Lite-On	LTST-C193KRKT-5A
28	1	D60	100 V, 1 A	On-Semi	MBRS1100T3G
29	1	D90	40 V, 1 A	Diodes Inc.	PD3S140-7
30	3	GP1_a, GP1_b, GP60	.1" Male Vert.	Würth	61300111121
31	1	J1	.156" Male Vert.	Würth	645002114822
32	1	J2	SMA Board Edge	Linx	CONSAM003.062
33	6	J70, J75, JP1, JP50, JP70, JP71	.1" Male Vert.	Würth	61300211121
34	1	JMP1	DNP		
35	1	L60	33 $\mu$ H, 2.8 A	CoilCraft	MSD1278-334
36	1	L80	10 $\mu$ H, 150 mA	Taiyo Yuden	LBR2012T100K
37	1	L90	47 $\mu$ H, 250mA	Würth	7440329470
38	1	L <sub>sns</sub>	110 nH	CoilCraft	22225Q-111JE
39	2	L <sub>zvs1r</sub> , L <sub>zvs2</sub> see addendum statement	390 nH	CoilCraft	29295Q-391JE
40	1	L <sub>zvs12</sub>	DNP	CoilCraft	TBD
41	5	P25, P71, P72, P77, P78	10k, DNP (1k)	Bournes, Murata	3266Y-1-103LF, PV37Y102C01B00
42	2	Q1_a, Q1_b	60 V, 150 m $\Omega$ with SB	EPC	EPC2108
43	1	Q60	100 V, 65 m $\Omega$	EPC	EPC2036
44	1	Q61	DNP (100 V, 6 A, 30 m $\Omega$ )	EPC	EPC2007C
45	3	R2_a, R2_b, R82	20 $\Omega$	Stackpole	RMCF0402JT20R0
46	2	R3_a, R3_b	27k	Panasonic	ERJ-2GEJ273X
47	2	R4_a, R4_b	4.7 $\Omega$	Panasonic	ERJ-2GEJ4R7X

(continued on next page)

**Table 3: Bill of Materials - Amplifier Board (continued)**

Item	Qty	Reference	Part Description	Manufacturer	Part #
48	1	R20	DNP (10k)	Panasonic	ERJ-2GEJ103X
49	1	R21	100k	Panasonic	ERJ-2GEJ104X
50	1	R25	7.5k	Panasonic	ERJ-2RKF7501X
51	1	R26	2k	Panasonic	ERJ-2RKF2001X
52	1	R30	100 Ω	Panasonic	ERJ-3EKF1000V
53	1	R31	51.0k 1%	Panasonic	ERJ-3EKF5102V
54	1	R32	8.2k 1%	Panasonic	ERJ-2RKF8201X
55	2	R33, R70	47k	Panasonic	ERJ-2RKF4702X
56	2	R35, R36	634 Ω	Panasonic	ERJ-2RKF6340X
57	1	R37	150k 1%	Panasonic	ERJ-2RKF1503X
58	2	R38, R91	49.9k 1%	Panasonic	ERJ-2RKF4992X
59	1	R40	196k	Panasonic	ERJ-3EKF1963V
60	1	R41	6.04k	Panasonic	ERJ-2RKF6041X
61	1	R42	24.9k	Panasonic	ERJ-2RKF2492X
62	1	R43	10.5k	Panasonic	ERJ-2RKF1052X
63	2	R44, R90	100k 1%	Panasonic	ERJ-2RKF1003X
64	1	R50	10 Ω	Panasonic	ERJ-3EKF10R0V
65	1	R51	124k 1%	Panasonic	ERJ-2RKF1243X
66	1	R52	71.5k 1%	Panasonic	ERJ-2RKF7152X
67	1	R53	1.00k	Panasonic	ERJ-2RKF1001X
68	1	R54	0 Ω	Yageo	RC0402JR-070RL
69	1	R60	40 mΩ, 0.4 W	Vishay Dale	WSLP0603R0400FEB
70	1	R61	150 mΩ, 0.25 W	Vishay Dale	WSL0805R1500FEA18
71	2	R71, R78	124 Ω	Panasonic	ERJ-2RKF1240X
72	2	R72, R77	22 Ω	Panasonic	ERJ-2RKF22R0X
73	2	R73, R75	10k	Panasonic	ERJ-2GEJ103X
74	1	R80	2.2 Ω	Yageo	RC0402JR-072R2L
75	1	R92	9.53k 1%	Panasonic	ERJ-2RKF9531X
76	2	TP1, TP2	SMD Probe Loop	Keystone	5015
77	1	Tsns	10 μH, 1:1, 96.9%	CoilCraft	PFD3215-103ME
78	2	U1_a, U1_b	100 V eGaN Driver	Texas Instruments	LM5113TM
79	1	U30	Power & Current Monitor	Linear	LT2940IMS#PBF
80	1	U35	DNP (Comparator)	Texas Instruments	TLV3201AIDBVR
81	1	U50	Boost Controller	Texas Instruments	LM3478MAX/NOPB
82	1	U70	Programmable Oscillator	KDS Daishinku America	DSO221SHF 6.780
83	2	U71, U77	2 In NAND	Fairchild	NC7SZ00L6X
84	2	U72, U78	2 In AND	Fairchild	NC7SZ08L6X
85	1	U80	Gate Driver with LDO	Texas Instruments	UCC27611DRV
86	1	U90	1.4 MHz, 24 V, 0.5A Buck	MPS	MP2357DJ-LF

*Addendum Statement: Ongoing testing of the EPC9509 revealed that the improvement in performance of the EPC2108 based design exceeded that of earlier design criteria and as such the design could further be improved to increase efficiency by changing Lzvs1 and Lzvs2 from 390nH (Coilcraft 2929SQ-391JEB) to 500nH (Coilcraft 2929SQ-501JEB).*

**Table 4: Bill of Materials - Source Coil**

Item	Qty	Reference	Part Description	Manufacturer	Part #
1	1	Ctrombone	120 pF, 1000 V	Vishay	VJ1111D12KXGAT
2	1	C1	3.3 pF, 1500 V	Vishay	VJ1111D3R3CXRAJ
3	1	C2	12 pF, 1500 V	Vishay	VJ1111D1120JXRAJ
4	1	C3	120 pF, 1000 V	Vishay	VJ1111D121KXGAT
5	1	PCB1	Class 3 Coil Former	NuCurrent	R26_RZTX_D1
6	2	C4, C6	DNP	—	—
7	1	C5	0 Ω, 0612	Vishay	RCL06120000Z0EA
8	1	J1	SMA PCB Edge	Linx	CON SMA013.031

**Table 5: Bill of Materials - Device Board**

Item	Qty	Reference	Part Description	Manufacturer	Part #
1	1	C84	100 nF, 50 V	Murata	GRM188R71H104KA93D
2	1	C85	10 μF, 50 V	Murata	GRM32DF51H106ZA01L
3	1	PCB1	Cat3PRU	Coastal Circuits	Cat3DeviceBoard
4	2	CM1, CM11	470 pF	Vishay	VJ1111D471KXLAT
5	4	CM2, CM12, CMP1, CMP2	DNP	—	—
6	3	CM5, CM7, CMP3, CMP4	DNP	—	—
7	1	CM6	56 pF	Vishay	VJ0505D560JXPAJ
8	1	CMP8	68 pF	Vishay	VJ0505D680JXCAJ
9	4	D80, D81, D82, D83	40 V, 1 A	Diodes Inc.	PD3S140-7
10	1	D84	LED 0603 Green	Lite-On	LTST-C193KGKT-5A
11	1	D85	2.7 V 250 mW	NXP	BZX84-C2V7,215
12	1	D86	LED 0603 Red	Lite-On	LTST-C193KRKT-5A
13	1	D87	33 V, 250 mW	NXP	BZX84-C33,215
14	2	J81, J82	.1" Male Vert.	Würth	61300211121
15	2	LM1, LM11	82 nH	Würth	744912182
16	1	R80	300 mΩ, 1 W	Stackpole	CSRN2512FKR300
17	1	R81	4.7k Ω	Stackpole	RMCF1206FT4K70
18	1	R82	422 Ω	Yageo	RMCF0603FT422R
19	4	TP1, TP2, TP3, TP4	SMD Probe Loop	Keystone	5015
20	1	JPR1	Wire Jumper at CM11	—	—

EPC would like to acknowledge Würth Electronics ([www.we-online.com/web/en/wuerth\\_elektronik/start.php](http://www.we-online.com/web/en/wuerth_elektronik/start.php)), Coilcraft ([www.coilcraft.com](http://www.coilcraft.com)), and KDS Daishinku America ([www.kdsamerica.com](http://www.kdsamerica.com)) for their support of this project.

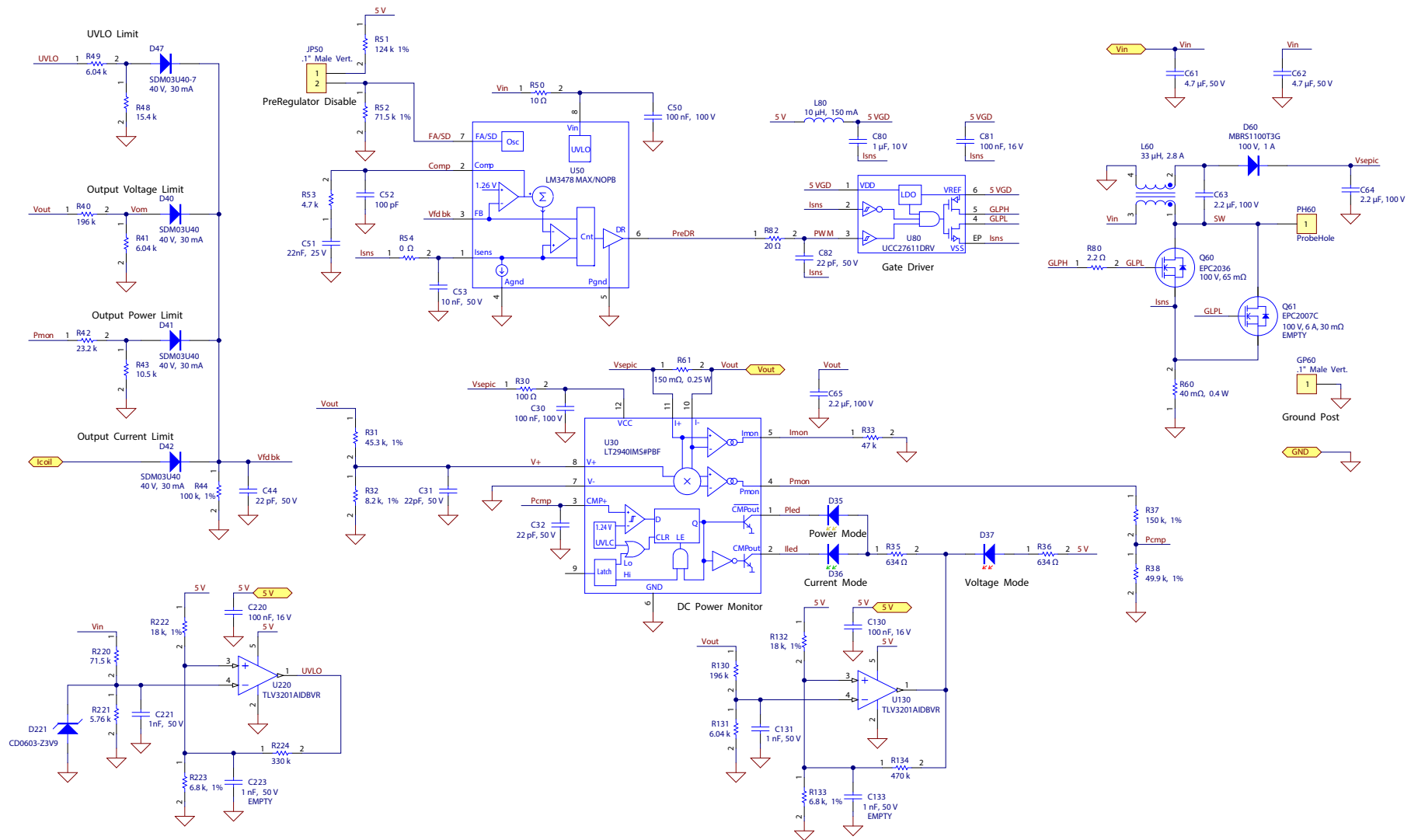

Addendum Statement; Ongoing testing of the EPC9509 revealed that the improvement in performance of the EPC2108 based design exceeded that of earlier design criteria and as such the design could further be improved to increase efficiency by changing Lzvs1 and Lzvs2 from 390nH (Coilcraft 2929SQ-391JEB) to 500nH (Coilcraft 2929SQ-501JEB).

Figure 11: EPC9509 - ZVS class-D amplifier schematic.

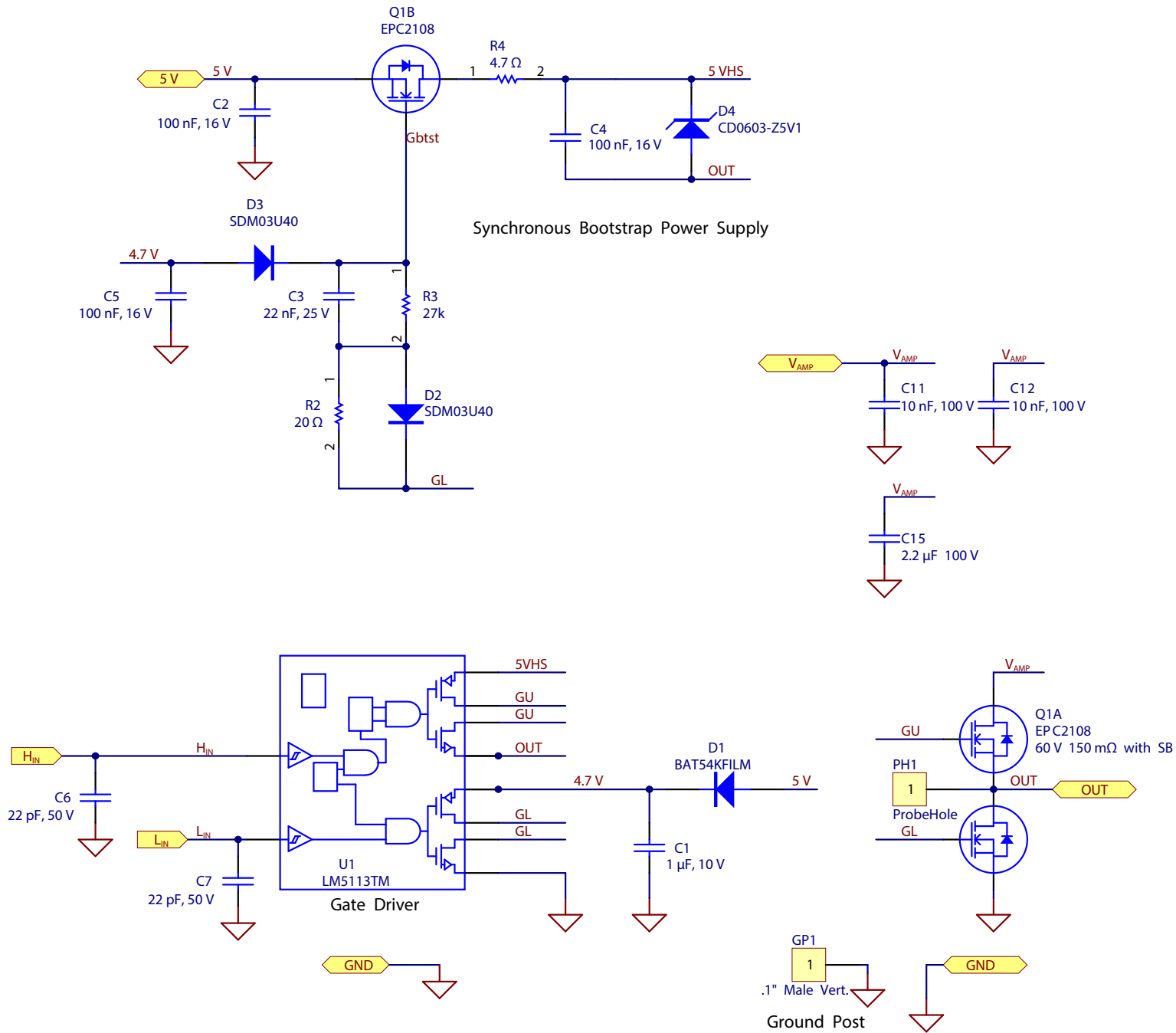

Figure 12: EPC9509 - Gate driver and power devices schematic  
 This schematic is repeated for each single-ended ZVS class D amplifier.

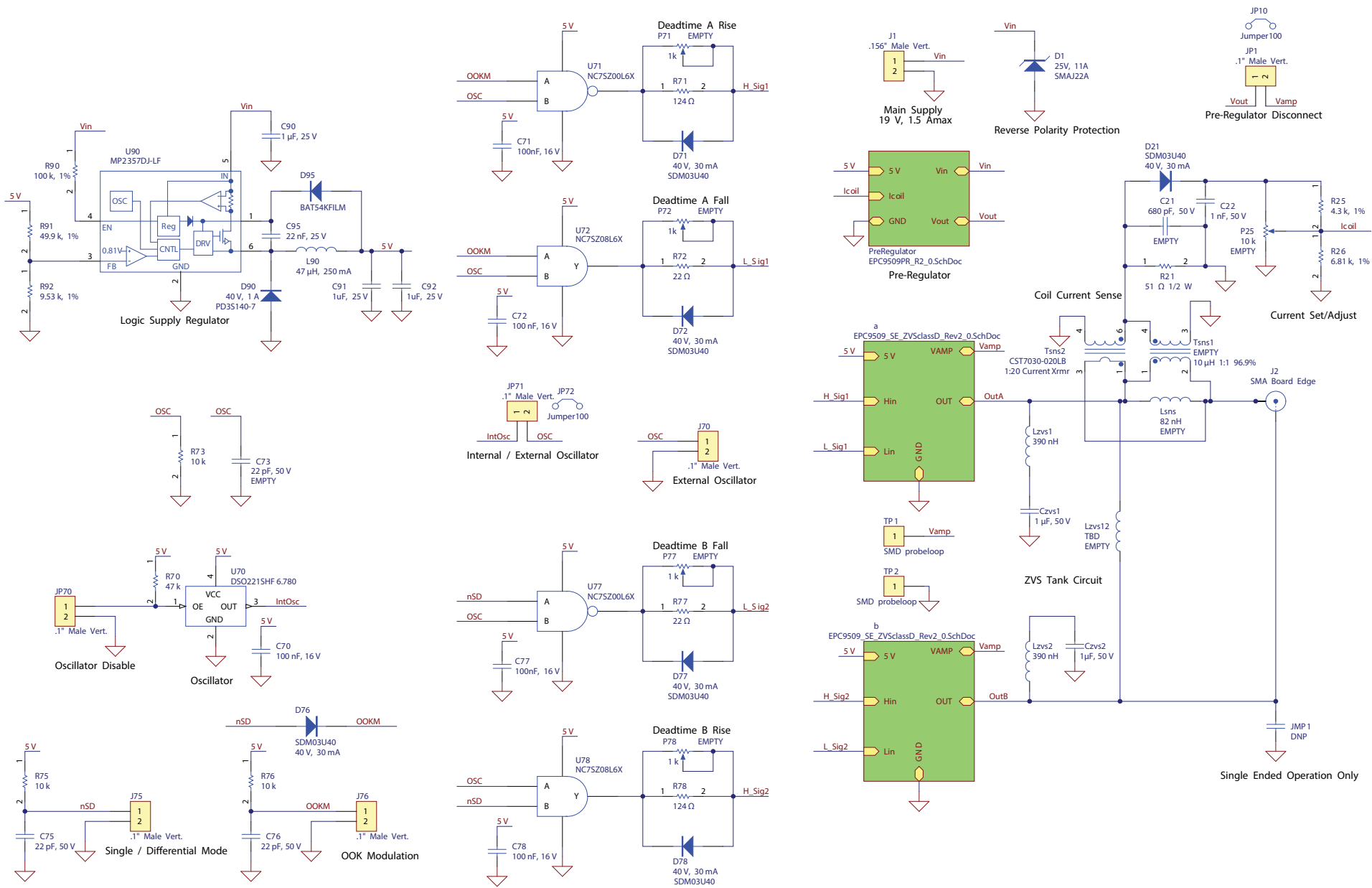

Figure 13: EPC9509 - Pre-regulator schematic.

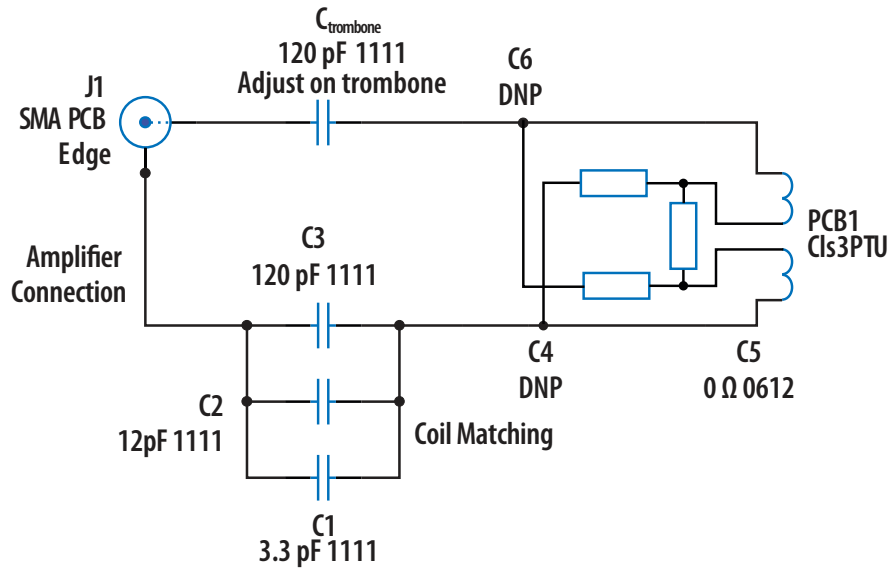

Figure 14: Class 3 source board schematic.

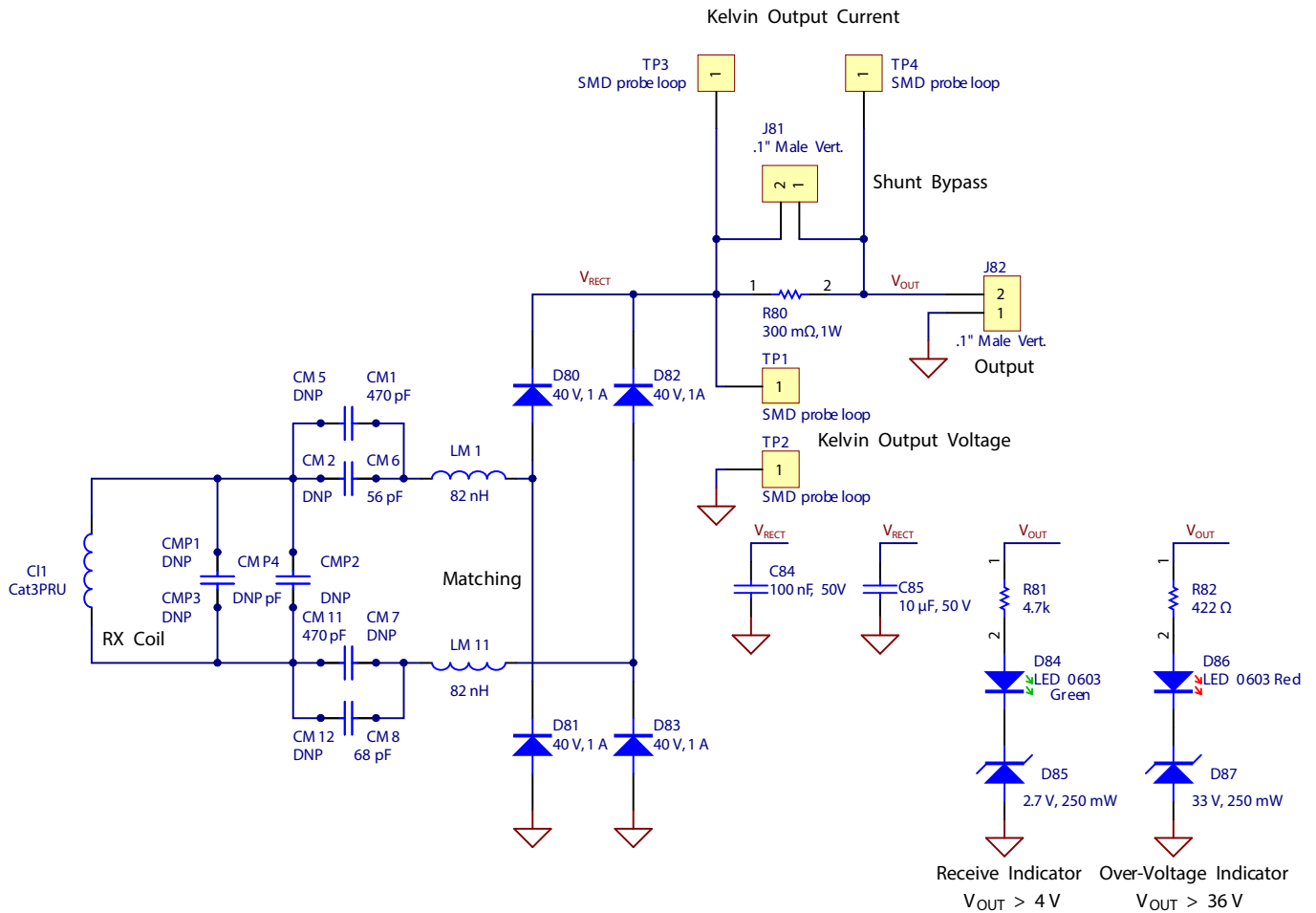

Figure 15: Category 3 device board schematic.

## For More Information:

Please contact [info@epc-co.com](mailto:info@epc-co.com)  
or your local sales representative

Visit our website:

[www.epc-co.com](http://www.epc-co.com)

Sign-up to receive  
EPC updates at  
[bit.ly/EPCupdates](http://bit.ly/EPCupdates)  
or text "EPC" to 22828



EPC Products are distributed through Digi-Key.

[www.digikey.com](http://www.digikey.com)

### Demonstration Board Warning and Disclaimer

The EPC9113 board is intended for product evaluation purposes only and is not intended for commercial use. Replace components on the Evaluation Board only with those parts shown on the parts list (or Bill of Materials) in the Quick Start Guide. Contact an authorized EPC representative with any questions.

This board is intended to be used by certified professionals, in a lab environment, following proper safety procedures. Use at your own risk.

As an evaluation tool, this board is not designed for compliance with the European Union directive on electromagnetic compatibility or any other such directives or regulations. As board builds are at times subject to product availability, it is possible that boards may contain components or assembly materials that are not RoHS compliant. Efficient Power Conversion Corporation (EPC) makes no guarantee that the purchased board is 100% RoHS compliant.

The Evaluation board (or kit) is for demonstration purposes only and neither the Board nor this Quick Start Guide constitute a sales contract or create any kind of warranty, whether express or implied, as to the applications or products involved.

Disclaimer: EPC reserves the right at any time, without notice, to make changes to any products described herein to improve reliability, function, or design. EPC does not assume any liability arising out of the application or use of any product or circuit described herein; neither does it convey any license under its patent rights, or other intellectual property whatsoever, nor the rights of others.