

Dual Channel Sensorless Motor Control IC for Appliances

Features

- **MCE™ (Motion Control Engine) - Hardware based computation engine for high efficiency sinusoidal sensorless control of permanent magnet AC motor**
- **Integrated Power Factor Correction control**
- **Supports both interior and surface permanent magnet motors**
- **Built-in hardware peripheral for single shunt current feedback reconstruction**
- **No external current or voltage sensing operational amplifier required**
- **Dual channel three/two-phase Space Vector PWM**
- **Three-channel analog output (PWM)**
- **Embedded 8-bit high speed microcontroller (8051) for flexible I/O and man-machine control**
- **JTAG programming port for emulation/debugger**
- **Two serial communication interface (UART)**
- **I²C/SPI serial interface**
- **Watchdog timer with independent analog clock**
- **Three general purpose timers/counters**
- **Two special timers: periodic timer, capture timer**
- **External EEPROM and internal RAM facilitate debugging and code development**
- **Pin compatible with IRMCK312, OTP-ROM version**
- **1.8V/3.3V CMOS**

Product Summary

Maximum crystal frequency	60 MHz
Maximum internal clock (SYSCLK) frequency	128 MHz
Sensorless control computation time	11 µsec typ
MCE™ computation data range	16 bit signed
Program RAM loaded from external EEPROM	48K bytes
Data RAM	8K bytes
GateKill latency (digital filtered)	2 µsec
PWM carrier frequency counter	16 bits/ SYSCLK
A/D input channels	11
A/D converter resolution	12 bits
A/D converter conversion speed	2 µsec
8051 instruction execution speed	2 SYSCLK
Analog output (PWM) resolution	8 bits
UART baud rate (typ)	57.6K bps
Number of I/O (max)	36
Package (lead-free)	QFP100

Description

IRMCF312 is a high performance RAM based motion control IC designed primarily for appliance applications. IRMCF312 is designed to achieve low cost and high performance control solutions for advanced inverterized appliance motor control. IRMCF312 contains two computation engines. One is Motion Control Engine (MCE™) for sensorless control of permanent magnet motors; the other is an 8-bit high-speed microcontroller (8051). Both computation engines are integrated into one monolithic chip. The MCE™ contains a collection of control elements such as Proportional plus Integral, Vector rotator, Angle estimator, Multiply/Divide, Low loss SVPWM, Single Shunt IFB. The user can program a motion control algorithm by connecting these control elements using a graphic compiler. Key components of the sensorless control algorithms, such as the Angle Estimator, are provided as complete pre-defined control blocks implemented in hardware. A unique analog/digital circuit and algorithm to fully support single shunt current reconstruction is also provided. The 8051 microcontroller performs 2-cycle instruction execution (60MIPS at 120MHz). The MCE and 8051 microcontroller are connected via dual port RAM to process signal monitoring and command input. An advanced graphic compiler for the MCE™ is seamlessly integrated into the MATLAB/Simulink environment, while third party JTAG based emulator tools are supported for 8051 developments. IRMCF312 comes with a small QFP100 pin lead-free package.

TABLE OF CONTENTS

1	Overview.....	4
2	IRMCF312 Block Diagram and Main Functions	5
3	Pinout.....	7
4	Input/Output of IRMCF312.....	8
4.1	8051 Peripheral Interface Group.....	9
4.2	Motion Peripheral Interface Group.....	10
4.3	Analog Interface Group	11
4.4	Power Interface Group.....	12
4.5	Test Interface.....	12
5	Application Connections	13
6	DC Characteristics.....	14
6.1	Absolute Maximum Ratings	14
6.2	System Clock Frequency and Power Consumption.....	14
6.3	Digital I/O DC Characteristics.....	15
6.4	PLL and Oscillator DC Characteristics.....	16
6.5	Analog I/O DC Characteristics	16
6.6	Analog I/O DC Characteristics	17
6.7	Under Voltage Lockout DC Characteristics	18
6.8	CMEXT and AREF Characteristics.....	18
7	AC Characteristics.....	19
7.1	PLL AC Characteristics	19
7.2	Analog to Digital Converter AC Characteristics	20
7.3	Op Amp AC Characteristics	21
7.4	Op Amp AC Characteristics	21
7.5	SYNC to SVPWM and A/D Conversion AC Timing.....	22
7.6	GATEKILL to SVPWM AC Timing.....	23
7.7	Interrupt AC Timing	23
7.8	I ² C AC Timing.....	24
7.9	SPI AC Timing.....	25
7.9.1	SPI Write AC timing.....	25
7.9.2	SPI Read AC Timing.....	26
7.10	UART AC Timing	27
7.11	CAPTURE Input AC Timing	28
7.12	JTAG AC Timing	29
8	Pin List.....	30
9	Package Dimensions.....	34
10	Part Marking Information.....	35

TABLE OF FIGURES

Figure 1.	Typical Application Block Diagram Using IRMCF312.....	4
Figure 2.	IRMCF312 Internal Block Diagram.....	5
Figure 3.	IRMCF312 Pin Configuration.....	7
Figure 4.	Input/Output of IRMCF312.....	8
Figure 5.	Application Connection of IRMCF312.....	13
Figure 6.	Clock Frequency vs. Power Consumption.....	14

TABLE OF TABLES

Table 1.	Absolute Maximum Ratings.....	14
Table 2.	System Clock Frequency.....	14
Table 3.	Digital I/O DC Characteristics.....	15
Table 4.	PLL DC Characteristics.....	16
Table 5.	Analog I/O DC Characteristics.....	16
Table 6.	Analog I/O DC Characteristics.....	17
Table 7.	UVcc DC Characteristics.....	18
Table 8.	CMEXT and AREF DC Characteristics.....	18
Table 9.	PLL AC Characteristics.....	19
Table 10.	A/D Converter AC Characteristics.....	20
Table 11.	Current Sensing OP Amp AC Characteristics.....	21
Table 12.	Voltage sensing OP Amp AC Characteristics.....	21
Table 13.	SYNC AC Characteristics.....	22
Table 14.	GATEKILL to SVPWM AC Timing.....	23
Table 15.	Interrupt AC Timing.....	23
Table 16.	I ² C AC Timing.....	24
Table 17.	SPI Write AC Timing.....	25
Table 18.	SPI Read AC Timing.....	26
Table 19.	UART AC Timing.....	27
Table 20.	CAPTURE AC Timing.....	28
Table 21.	JTAG AC Timing.....	29
Table 22.	Pin List.....	33

1 Overview

IRMCF312 is a new International Rectifier integrated circuit device primarily designed as a one-chip solution for complete inverter controlled appliance dual motor control applications. Unlike a traditional microcontroller or DSP, the IRMCF312 provides a built-in closed loop sensorless control algorithm using the unique Motion Control Engine (MCE™) for permanent magnet motors. The MCE™ consists of a collection of control elements, motion peripherals, a dedicated motion control sequencer and dual port RAM to map internal signal nodes. IRMCF312 also employs a unique single shunt current reconstruction circuit to eliminate additional analog/digital circuitry and enables a direct shunt resistor interface to the IC. The sensorless control is the same for both motors with a single shunt current sensing capability. Motion control programming is achieved using a dedicated graphical compiler integrated into the MATLAB/Simulink™ development environment. Sequencing, user interface, host communication, and upper layer control tasks can be implemented in the 8051 high-speed 8-bit microcontroller. The 8051 microcontroller is equipped with a JTAG port to facilitate emulation and debugging tools. Figure 1 shows a typical application schematic using IRMCF312.

IRMCF312 is intended for development purpose and contains 48K bytes of RAM, which can be loaded from external EEPROM for 8051 program execution. For high volume production, IRMCK312 contains OTP ROM in place of program RAM to reduce the cost. Both IRMCF312 and IRMCK312 come in the same 100-pin QFP package with identical pin configuration to facilitate PC board layout and transition to mass production

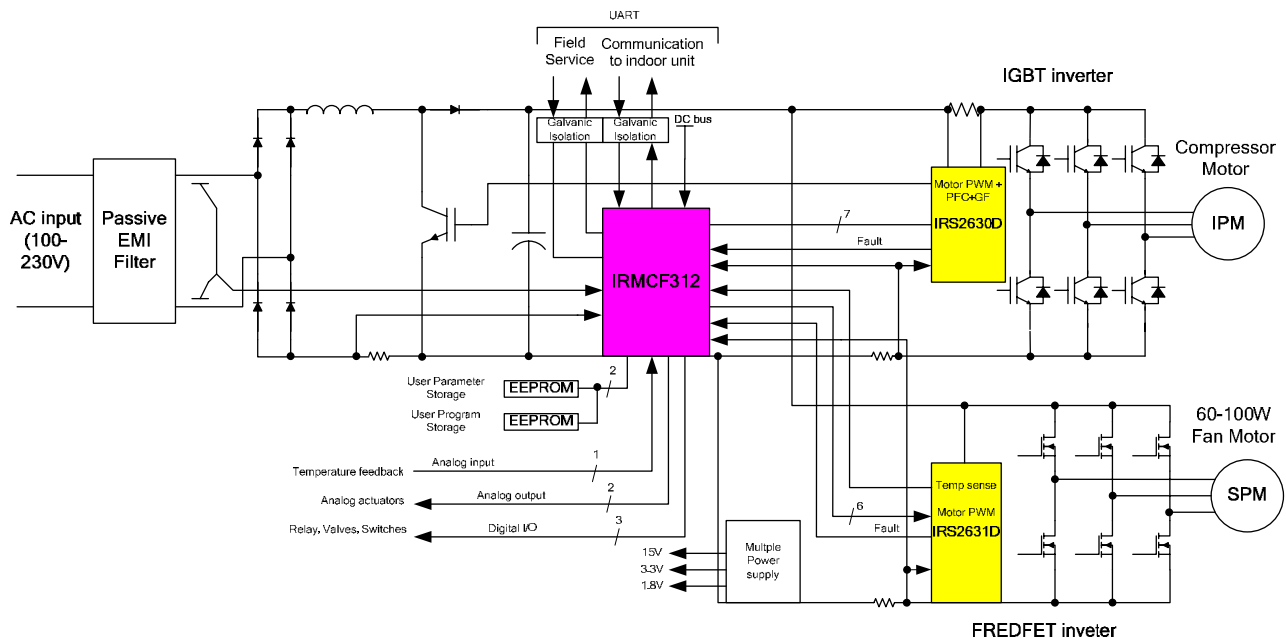

Figure 1. Typical Application Block Diagram Using IRMCF312

2 IRMCF312 Block Diagram and Main Functions

IRMCF312 block diagram is shown in Figure 2.

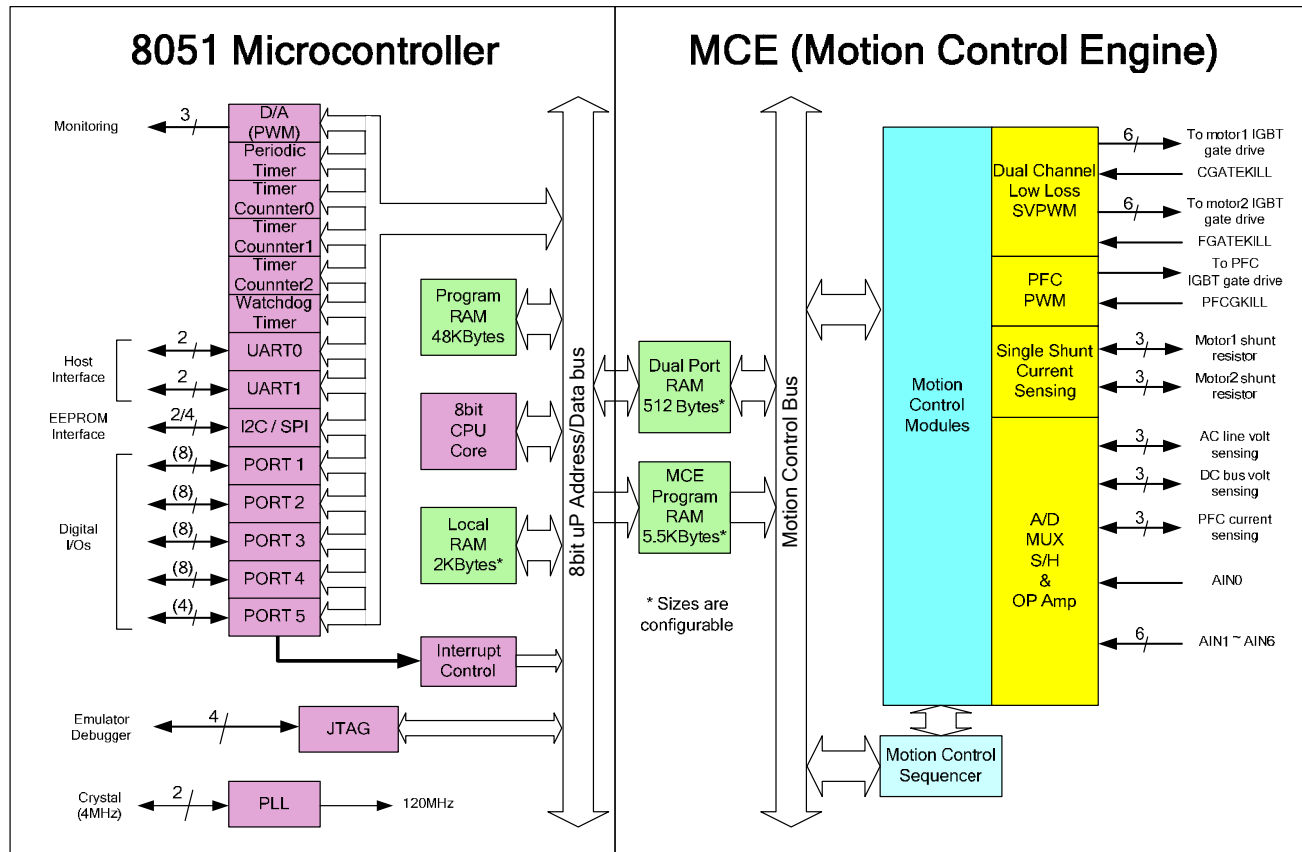

Figure 2. IRMCF312 Internal Block Diagram

IRMCF312 contains the following functions for sensorless AC motor control applications:

- Motion Control Engine (MCE™)
 - Proportional plus Integral block
 - Low pass filter
 - Differentiator and lag (high pass filter)
 - Ramp
 - Limit
 - Angle estimate (sensorless control)
 - Inverse Clark transformation
 - Vector rotator
 - Bit latch

- Peak detect
 - Transition
 - Multiply-divide (signed and unsigned)
 - Divide (signed and unsigned)
 - Adder
 - Subtractor
 - Comparator
 - Counter
 - Accumulator
 - Switch
 - Shift
 - ATAN (arc tangent)
 - Function block (any curve fitting, nonlinear function)
 - 16-bit wide Logic operations (AND, OR, XOR, NOT, NEGATE)
 - MCE™ program and data memory (6K byte).^{Note 1}
 - MCE™ control sequencer
- 8051 microcontroller
 - Three 16-bit timer/counters
 - 16-bit periodic timer
 - 16-bit analog watchdog timer
 - 16-bit capture timer
 - Up to 36 discrete I/Os
 - Eleven-channel 12-bit A/D
 - Five buffered channels (0 – 1.2V input)
 - Six unbuffered channels (0 – 1.2V input)
 - JTAG port (4 pins)
 - Up to three channels of analog output (8-bit PWM)
 - Two UART
 - I²C/SPI port
 - 48K byte program RAM loaded from external EEPROM
 - 2K byte data RAM.^{Note 1}

Note 1: Total size of RAM is 8K byte including MCE program, MCE data, and 8051 data. Different sizes can be allocated depending on applications.

3 Pinout

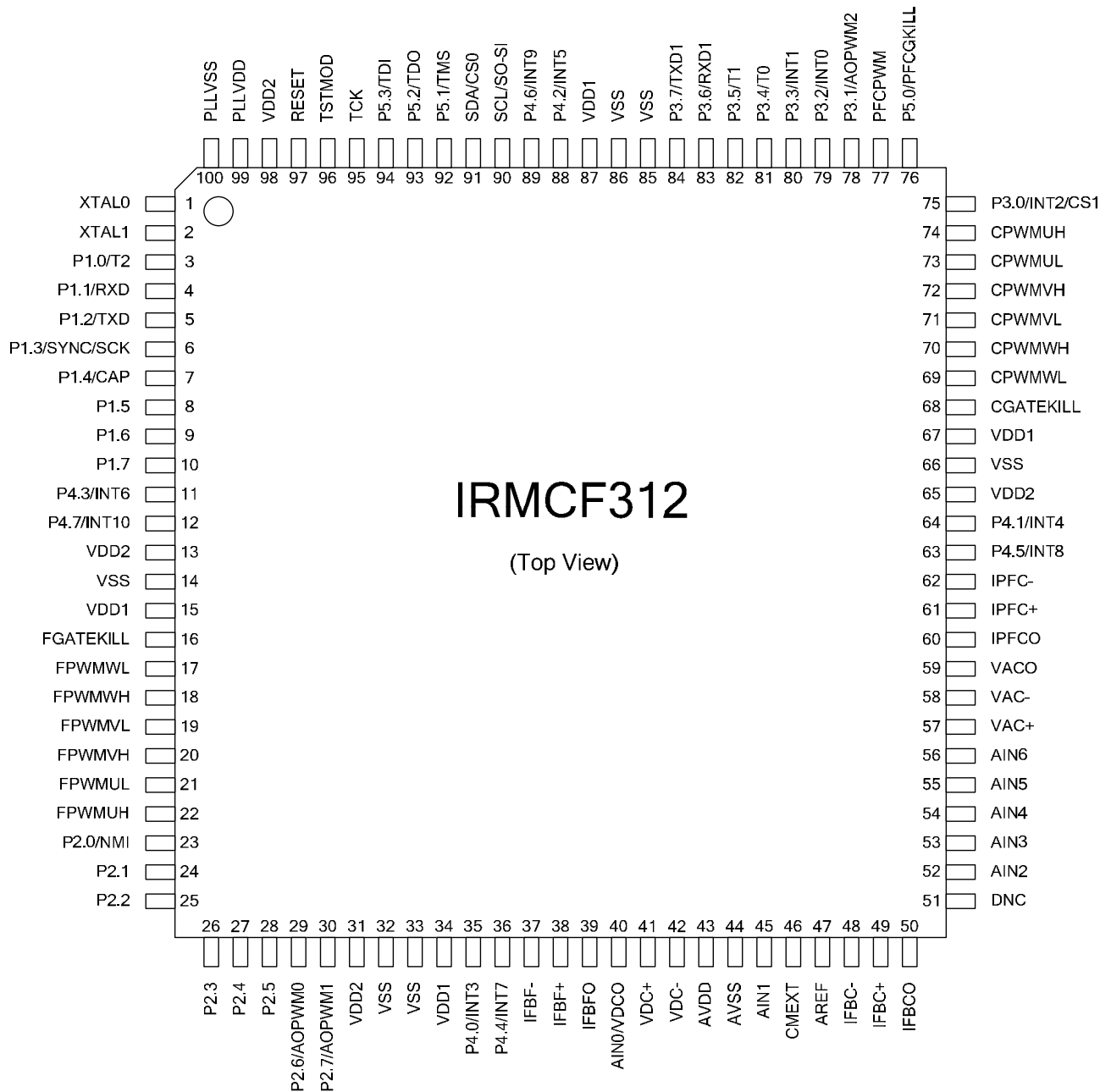

Figure 3. IRMCF312 Pin Configuration

Attention: Pin 51 must be left floating. Do not connect.

4 Input/Output of IRMCF312

All I/O signals of IRMCF312 are shown in Figure 4. All I/O pins are 3.3V logic interface except A/D interface pins.

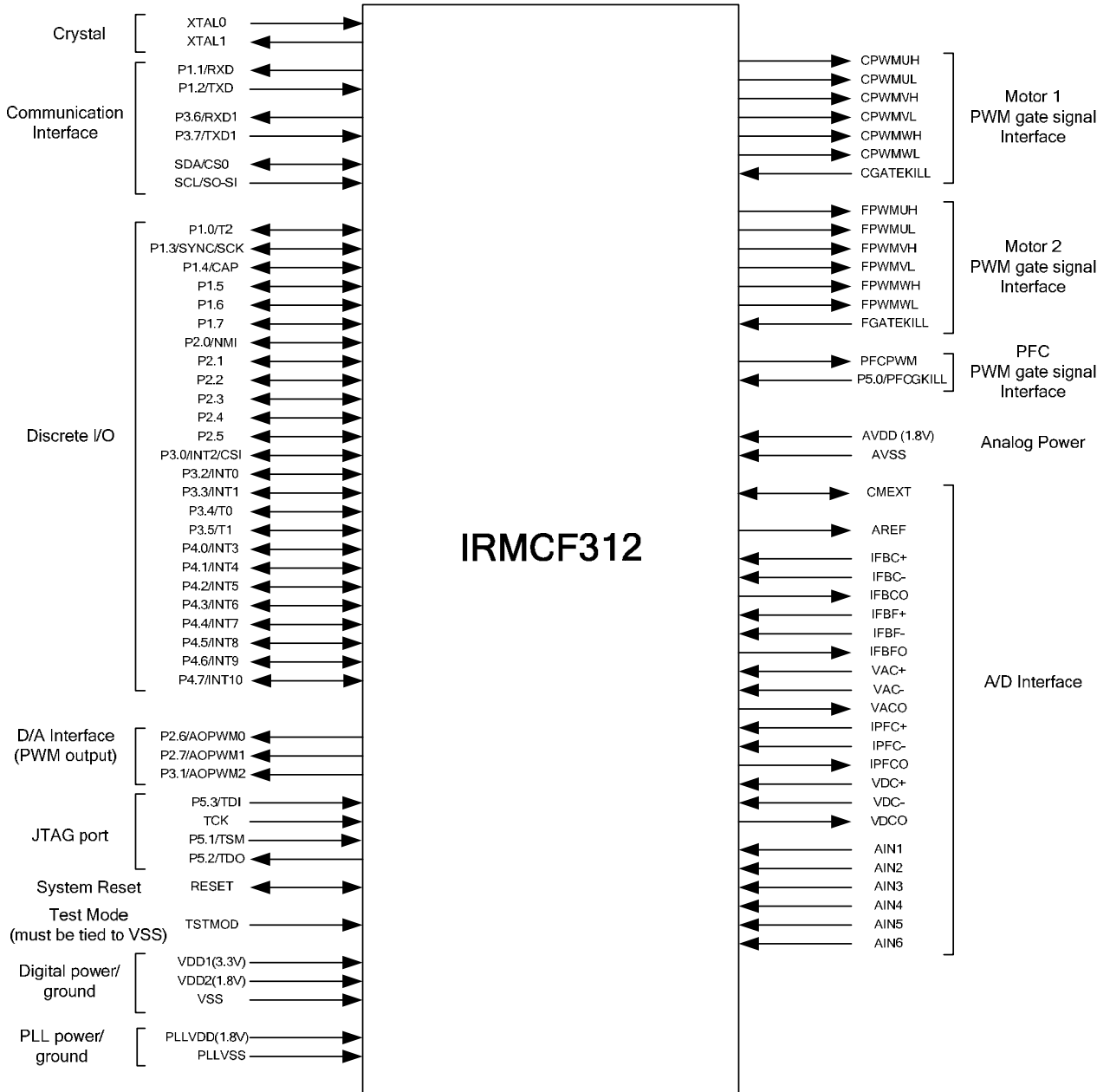

Figure 4. Input/Output of IRMCF312

4.1 8051 Peripheral Interface Group

UART Interface

P1.1/RXD	Input, Receive data to IRMCF312, can be configured as P1.1
P1.2/TXD	Output, Transmit data from IRMCF312, can be configured as P1.2
P3.6/RXD1	Input, 2 nd channel Receive data to IRMCF312, can be configured as P3.6
P3.7/TXD1	Output, 2 nd channel Transmit data from IRMCF312, can be configured as P3.7

Discrete I/O Interface

P1.0/T2	Input/output port 1.0, can be configured as Timer/Counter 2 input
P1.3/SYNC/SCK	Input/output port 1.3, can be configured as SYNC output or SPI clock, needs to be pulled up to VDD1 in order to boot from I ² C EEPROM
P1.4/CAP	Input/output port 1.4, can be configured as Capture Timer input
P1.5	Input/output port 1.5
P1.6	Input/output port 1.6
P1.7	Input/output port 1.7
P2.0/NMI	Input/output port 2.0, can be configured as non-maskable interrupt
P2.1	Input/output port 2.1
P2.2	Input/output port 2.2
P2.3	Input/output port 2.3
P2.4	Input/output port 2.4
P2.5	Input/output port 2.5
P3.0/INT2/CS1	Input/output port 3.0, can be configured as external interrupt 2 or SPI chip select 1
P3.2/INT0	Input/output port 3.2, can be configured as external interrupt 0
P3.3/INT1	Input/output port 3.3, can be configured as external interrupt 1
P3.4/T0	Input/output port 3.4, can be configured as Timer/Counter 0 input
P3.5/T1	Input/output port 3.5, can be configured as Timer/Counter 1 input
P4.0/INT3	Input/output port 4.0, can be configured as external interrupt 3
P4.1/INT4	Input/output port 4.1, can be configured as external interrupt 4
P4.2/INT5	Input/output port 4.2, can be configured as external interrupt 5
P4.3/INT6	Input/output port 4.3, can be configured as external interrupt 6
P4.4/INT7	Input/output port 4.4, can be configured as external interrupt 7
P4.5/INT8	Input/output port 4.5, can be configured as external interrupt 8
P4.6/INT9	Input/output port 4.6, can be configured as external interrupt 9
P4.7/INT10	Input/output port 4.7, can be configured as external interrupt 10
P5.0/PFCGKILL	Input/output port 5.0, can be configured as PFCGKILL
P5.1/TMS	Input/output port 5.1, can be configured as JTAG TMS pin
P5.2/TDO	Input/output port 5.2, can be configured as JTAG TDO pin
P5.3/TDI	Input/output port 5.3, can be configured as JTAG TDI pin

Analog Output Interface

P2.6/AOPWM0	Input/output, can be configured as 8-bit PWM output 0 with programmable carrier frequency
P2.7/AOPWM1	Input/output, can be configured as 8-bit PWM output 1 with programmable carrier frequency
P3.1/AOPWM2	Input/output, can be configured as 8-bit PWM output 2 with programmable carrier frequency

Crystal Interface

XTAL0	Input, connected to crystal
XTAL1	Output, connected to crystal

Reset Interface

RESET	Inout, system reset, needs to be pulled up to VDD1 but doesn't require external RC time constant
-------	--

I²C/SPI Interface

SCL/SO-SI	Output, I ² C clock output, SPI SO-SI
SDA/CS0	Input/output, I ² C Data line, Chip Select 0 of SPI
P3.0/INT2/CS1	Input/output port 3.0, can be configured as external interrupt 2 or SPI chip select 1
P1.3/SYNC/SCK	Input/output port 1.3, can be configured as SYNC output or SPI clock, needs to be pulled up to VDD1 in order to boot from I ² C EEPROM

4.2 Motion Peripheral Interface Group

PWM

CPWMUH	Output, motor 1 PWM phase U high side gate signal
CPWMUL	Output, motor 1 PWM phase U low side gate signal
CPWMVH	Output, motor 1 PWM phase V high side gate signal
CPWMVL	Output, motor 1 PWM phase V low side gate signal
CPWMWH	Output, motor 1 PWM phase W high side gate signal
CPWMWL	Output, motor 1 PWM phase W low side gate signal
FPWMUH	Output, motor 2 PWM phase U high side gate signal
FPWMUL	Output, motor 2 PWM phase U low side gate signal
FPWMVH	Output, motor 2 PWM phase V high side gate signal
FPWMVL	Output, motor 2 PWM phase V low side gate signal
FPWMWH	Output, motor 2 PWM phase W high side gate signal
FPWMWL	Output, motor 2 PWM phase W low side gate signal
PFCPWM	Output, PFC PWM

Fault

CGATEKILL	Input, upon assertion, this negates all six PWM signals for motor 1, programmable logic sense
P5.0/PFCGKILL	Input, upon assertion, this negates PFCPWM signal, programmable logic sense, can be configured as discrete I/O in which case CGATEKILL negates PFCPWM
FGATEKILL	Input, upon assertion, this negates all six PWM signals for motor 2, programmable logic sense

4.3 Analog Interface Group

AVDD	Analog power (1.8V)
AVSS	Analog power return
AREF	Buffered 0.6V output
CMEXT	Unbuffered 0.6V, input to the AREF buffer, capacitor needs to be connected.
IFBC+	Input, Operational amplifier positive input for shunt resistor current sensing of motor 1
IFBC-	Input, Operational amplifier negative input for shunt resistor current sensing of motor 1
IFBCO	Output, Operational amplifier output for shunt resistor current sensing of motor 1
IFBF+	Input, Operational amplifier positive input for shunt resistor current sensing of motor 2
IFBF-	Input, Operational amplifier negative input for shunt resistor current sensing of motor 2
IFBFO	Output, Operational amplifier output for shunt resistor current sensing of motor 2
IPFC+	Input, Operational amplifier positive input for PFC current sensing
IPFC-	Input, Operational amplifier negative input for PFC current sensing
IPFO	Output, Operational amplifier output for PFC current sensing
VAC+	Input, Operational amplifier positive input for PFC AC voltage sensing
VAC-	Input, Operational amplifier negative input for PFC AC voltage sensing
VACO	Output, Operational amplifier output for PFC AC voltage sensing
VDC+	Input, Operational amplifier positive input for DC bus voltage sensing
VDC-	Input, Operational amplifier negative input for DC bus voltage sensing
AIN0/VDCO	Input/Output, Analog input channel 0 or Operational amplifier output for DC bus voltage sensing
AIN1	Input, Analog input channel 1 (0-1.2V), needs to be pulled down to AVSS if unused
AIN2	Input, Analog input channel 2 (0-1.2V), needs to be pulled down to AVSS if unused

AIN3	Input, Analog input channel 3 (0-1.2V), needs to be pulled down to AVSS if unused
AIN4	Input, Analog input channel 4 (0-1.2V), needs to be pulled down to AVSS if unused
AIN5	Input, Analog input channel 5 (0-1.2V), needs to be pulled down to AVSS if unused
AIN6	Input, Analog input channel 6 (0-1.2V), needs to be pulled down to AVSS if unused

4.4 Power Interface Group

VDD1	Digital power for I/O (3.3V)
VDD2	Digital power for core logic (1.8V)
VSS	Digital common
PLLVDD	PLL power (1.8V)
PLLVSS	PLL ground return

4.5 Test Interface

TSTMOD	Must be tied to VSS, used only for factory testing.
P5.3/TDI	Input, JTAG test data input
P5.1/TMS	Input, JTAG test mode select
TCK	Input, JTAG test clock
P5.2/TDO	Output, JTAG test data output

5 Application Connections

Typical application connection is shown in Figure 5. All components necessary to implement a complete sensorless drive control algorithm are shown connected to IRMCF312.

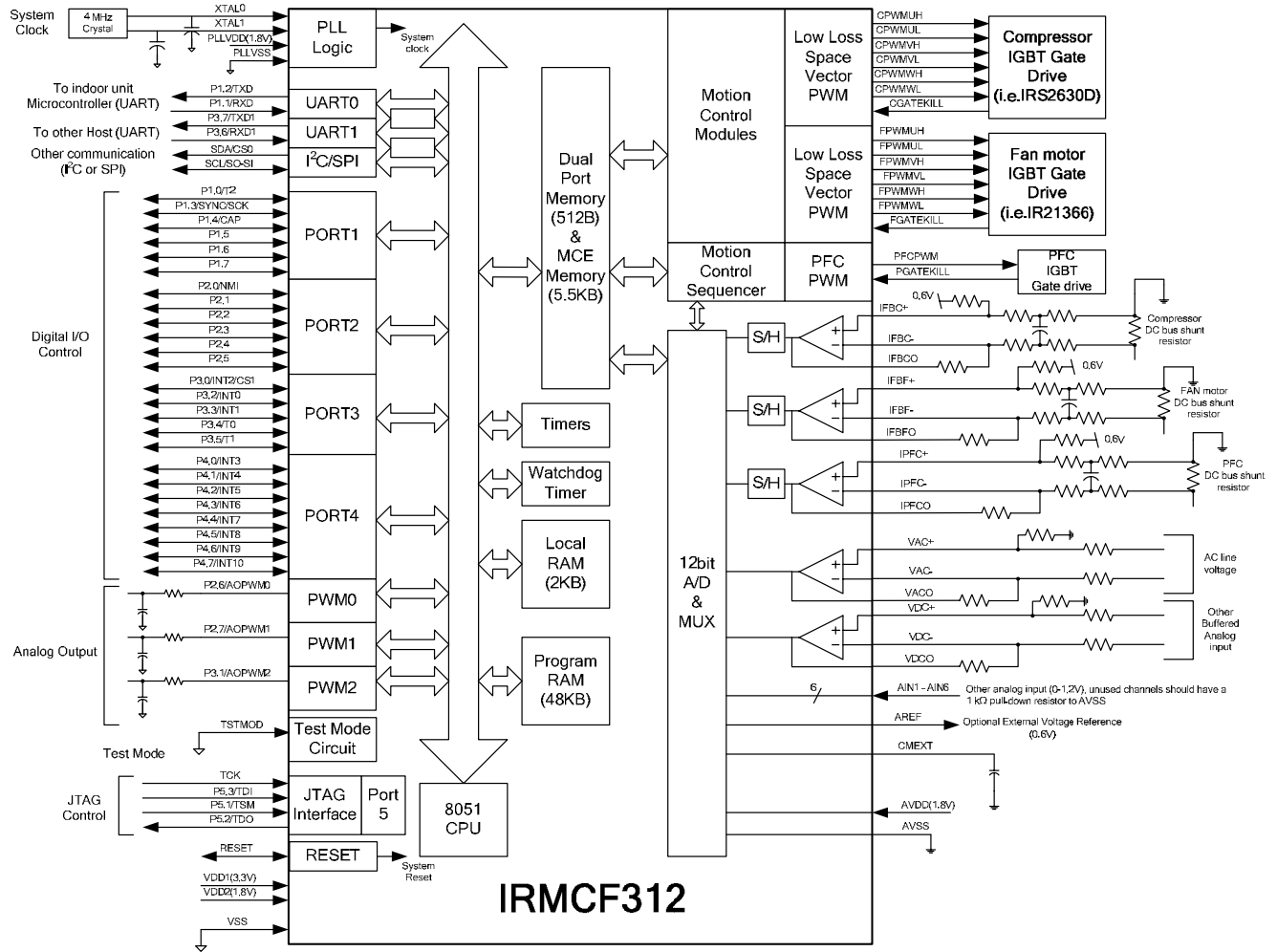

Figure 5. Application Connection of IRMCF312

6 DC Characteristics

6.1 Absolute Maximum Ratings

Symbol	Parameter	Min	Typ	Max	Condition
V _{DD1}	Supply Voltage	-0.3 V	-	3.6 V	Respect to VSS
V _{DD2}	Supply Voltage	-0.3 V	-	1.98 V	Respect to VSS
V _{IA}	Analog Input Voltage	-0.3 V	-	1.98 V	Respect to AVSS
V _{ID}	Digital Input Voltage	-0.3 V	-	3.65 V	Respect to VSS
T _A	Ambient Temperature	-40 °C	-	85 °C	
T _S	Storage Temperature	-65 °C	-	150 °C	

Table 1. Absolute Maximum Ratings

Caution: Stresses beyond those listed in “Absolute Maximum Ratings” may cause permanent damage to the device. These are stress ratings only and function of the device at these or any other conditions beyond those indicated in the operational sections of the specifications are not implied.

6.2 System Clock Frequency and Power Consumption

Symbol	Parameter	Min	Typ	Max	Unit
SYSCLK	System Clock	32	-	128	MHz

Table 2. System Clock Frequency

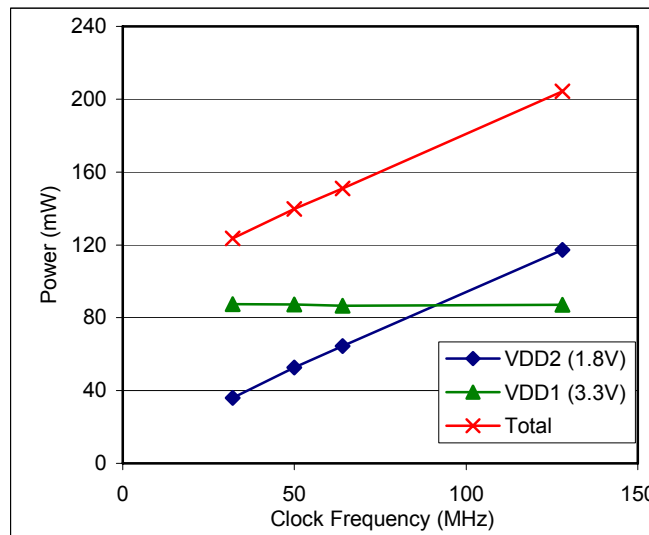

Figure 6. Clock Frequency vs. Power Consumption

6.3 Digital I/O DC Characteristics

Symbol	Parameter	Min	Typ	Max	Condition
V _{DD1}	Supply Voltage	3.0 V	3.3 V	3.6 V	Recommended
V _{DD2}	Supply Voltage	1.62 V	1.8 V	1.98 V	Recommended
V _{IL}	Input Low Voltage	-0.3 V	-	0.8 V	Recommended
V _{IH}	Input High Voltage	2.0 V		3.6 V	Recommended
C _{IN}	Input capacitance	-	3.6 pF	-	(1)
I _L	Input leakage current		±10 nA	±1 µA	V _O = 3.3 V or 0 V
I _{OL1} ⁽²⁾	Low level output current	8.9 mA	13.2 mA	15.2 mA	V _{OL} = 0.4 V (1)
I _{OH1} ⁽²⁾	High level output current	12.4 mA	24.8 mA	38 mA	V _{OH} = 2.4 V (1)
I _{OL2} ⁽³⁾	Low level output current	17.9 mA	26.3 mA	33.4 mA	V _{OL} = 0.4 V (1)
I _{OH2} ⁽³⁾	High level output current	24.6 mA	49.5 mA	81 mA	V _{OH} = 2.4 V (1)

Table 3. Digital I/O DC Characteristics

Note:

- (1) Data guaranteed by design.
- (2) Applied to SCL/SO-SI, SDA/CS0 pins.
- (3) Applied to P1.0/T2, P1.1/RXD, P1.2/TXD, P1.3/SYNC/SCK, P1.4/CAP, P1.5, P1.6, P1.7, P2.0/NMI, P2.1, P2.2, P2.3, P2.4, P2.5, P2.6/AOPWM0, P2.7/AOPWM1, P3.0/INT2/CS1, P3.1/AOPWM2, P3.2/INT0, P3.3/INT1, P3.4/T0, P3.5/T1, P3.6/RXD1, P3.7/TXD1, P4.0/INT3, P4.1/INT4, P4.2/INT5, P4.3/INT6, P4.4/INT7, P4.5/INT8, P4.6/INT9, P4.7/INT10, P5.0/PFCGKILL, P5.1/TMS, P5.2/TDO, P5.3/TDI, CGATEKILL, FGATEKILL, CPWMUL, CPWMUH, CPWMVL, CPWMVH, CPWMWL, CPWMWH, FPWMUL, FPWMUH, FPWMVL, FPWMVH, FPWMWL, FPWMWH, and PFCPWM pins.

6.4 PLL and Oscillator DC Characteristics

Symbol	Parameter	Min	Typ	Max	Condition
$V_{PLLVD D}$	Supply Voltage	1.62 V	1.8 V	1.92 V	Recommended
$V_{IL OSC}$	Oscillator Input Low Voltage	$V_{PLL VSS}$	-	0.2* $V_{PLL VDD}$	$V_{PLL VDD} = 1.8 V$ (1)
$V_{IH OSC}$	Oscillator Input High Voltage	0.8* $V_{PLL VDD}$		$V_{PLL VDD}$	$V_{PLL VDD} = 1.8 V$ (1)

Table 4. PLL DC Characteristics

Note:

(1) Data guaranteed by design.

6.5 Analog I/O DC Characteristics

- OP amps for current sensing (IFBC+, IFBC-, IFBCO, IFBF+, IFBF-, IFBFO, IPFC+, IPFC-, IPFCO)

$C_{AREF} = 1nF$, $C_{MEXT} = 100nF$. Unless specified, $T_a = 25^{\circ}C$.

Symbol	Parameter	Min	Typ	Max	Condition
V_{AVDD}	Supply Voltage	1.71 V	1.8 V	1.89 V	Recommended
V_{OFFSET}	Input Offset Voltage	-	-	26 mV	$V_{AVDD} = 1.8 V$
V_I	Input Voltage Range	0 V		1.2 V	Recommended
V_{OUTSW}	OP amp output operating range	50 mV (1)	-	1.2 V	$V_{AVDD} = 1.8 V$
C_{IN}	Input capacitance	-	3.6 pF	-	(1)
R_{FDBK}	OP amp feedback resistor	5 k Ω	-	20 k Ω	Requested between op amp output and negative input
OP_{GAINCL}	Operating Close loop Gain	80 db	-	-	(1)
CMRR	Common Mode Rejection Ratio	-	80 db	-	(1)
I_{SRC}	Op amp output source current	-	1 mA	-	$V_{OUT} = 0.6 V$ (1)
I_{SNK}	Op amp output sink current	-	100 μA	-	$V_{OUT} = 0.6 V$ (1)

Table 5. Analog I/O DC Characteristics

Note:

(1) Data guaranteed by design.

6.6 Analog I/O DC Characteristics

- OP amps for voltage sensing (VAC+, VAC-, VACO, VDC+, VDC-, VDCO)

$C_{AREF} = 1\text{nF}$, $C_{MEXT} = 100\text{nF}$. Unless specified, $T_a = 25^\circ\text{C}$.

Symbol	Parameter	Min	Typ	Max	Condition
V_{AVDD}	Supply Voltage	1.71 V	1.8 V	1.89 V	
V_{OFFSET}	Input Offset Voltage	-	-	26 mV	$V_{AVDD} = 1.8\text{ V}$
V_I	Input Voltage Range	0 V		1.2 V	
V_{OUTSW}	OP amp output operating range	50 mV ⁽¹⁾	-	1.2 V	$V_{AVDD} = 1.8\text{ V}$
C_{IN}	Input capacitance	-	3.6 pF	-	(1)
OP_{GAINCL}	Operating Close loop Gain	80 db	-	-	(1)
CMRR	Common Mode Rejection Ratio	-	80 db	-	(1)
I_{SRC}	Op amp output source current	-	5 mA	-	$V_{OUT} = 0.6\text{ V}$ (1)
I_{SNK}	Op amp output sink current	-	500 μA	-	$V_{OUT} = 0.6\text{ V}$ (1)

Table 6. Analog I/O DC Characteristics

Note:

(1) Data guaranteed by design.

6.7 Under Voltage Lockout DC Characteristics

- Based on AVDD (1.8V)

Unless specified, Ta = 25°C.

Symbol	Parameter	Min	Typ	Max	Condition
UV _{CC+}	UVcc positive going Threshold	1.53 V	1.66 V	1.71 V	V _{DD1} = 3.3 V
UV _{CC-}	UVcc negative going Threshold	1.52 V	1.62 V	1.71 V	V _{DD1} = 3.3 V
UV _{CCH}	UVcc Hysteresys	-	40 mV	-	

Table 7. UVcc DC Characteristics

6.8 CMEXT and AREF Characteristics

C_{AREF} = 1nF, C_{CMEXT} = 100nF. Unless specified, Ta = 25°C.

Symbol	Parameter	Min	Typ	Max	Condition
V _{CM}	CMEXT voltage	495 mV	600 mV	700 mV	V _{AVDD} = 1.8 V
V _{AREF}	Buffer Output Voltage	495 mV	600 mV	700 mV	V _{AVDD} = 1.8 V
ΔV _o	Load regulation (V _{DC} -0.6)	-	1 mV	-	(1)
PSRR	Power Supply Rejection Ratio	-	75 db	-	(1)

Table 8. CMEXT and AREF DC Characteristics

Note:

(1) Data guaranteed by design.

7 AC Characteristics

7.1 PLL AC Characteristics

Symbol	Parameter	Min	Typ	Max	Condition
F _{CLKIN}	Crystal input frequency	3.2 MHz	4 MHz	60 MHz	⁽¹⁾ (see figure below)
F _{PLL}	Internal clock frequency	32 MHz	50 MHz	128 MHz	⁽¹⁾
F _{LWPW}	Sleep mode output frequency	F _{CLKIN} ÷ 256	-	-	⁽¹⁾
J _S	Short time jitter	-	200 psec	-	⁽¹⁾
D	Duty cycle	-	50 %	-	⁽¹⁾
T _{LOCK}	PLL lock time	-	-	500 μsec	⁽¹⁾

Table 9. PLL AC Characteristics

Note:

(1) Data guaranteed by design.

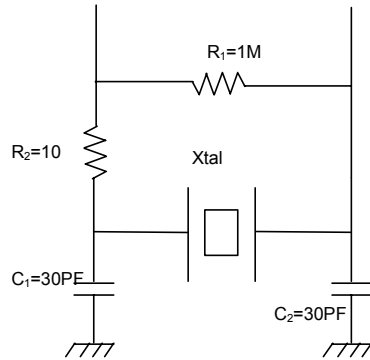

7.2 Analog to Digital Converter AC Characteristics

Unless specified, $T_a = 25^\circ\text{C}$.

Symbol	Parameter	Min	Typ	Max	Condition
T_{CONV}	Conversion time	-	-	2.05 μsec	(1)
T_{HOLD}	Sample/Hold maximum hold time	-	-	10 μsec	Voltage droop \leq 15 LSB (see figure below)

Table 10. A/D Converter AC Characteristics

Note:

(1) Data guaranteed by design.

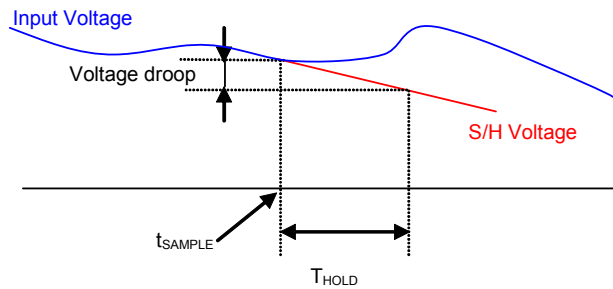

7.3 Op Amp AC Characteristics

- OP amps for current sensing (IFBC+, IFBC-, IFBCO, IFBF+, IFBF-, IFBFO, IPFC+, IPFC-, IPFCO)

Unless specified, Ta = 25°C.

Symbol	Parameter	Min	Typ	Max	Condition
OP _{SR}	OP amp slew rate	-	10 V/μsec	-	V _{AVDD} = 1.8 V, CL = 33 pF ⁽¹⁾
OP _{IMP}	OP input impedance	-	10 ⁸ Ω	-	(1)
T _{SET}	Settling time	-	400 ns	-	V _{AVDD} = 1.8 V, CL = 33 pF ⁽¹⁾

Table 11. Current Sensing OP Amp AC Characteristics

Note:

(1) Data guaranteed by design.

7.4 Op Amp AC Characteristics

- OP amps for voltage sensing (VAC+, VAC-, VACO, VDC+, VDC-, VDCO)

Unless specified, Ta = 25°C.

Symbol	Parameter	Min	Typ	Max	Condition
OP _{SR}	OP amp slew rate		2.5 V/μsec	-	V _{AVDD} = 1.8 V, CL = 33 pF ⁽¹⁾
OP _{IMP}	OP input impedance	-	10 ⁸ Ω	-	(1)
T _{SET}	Settling time		650 ns		V _{AVDD} = 1.8 V, CL = 33 pF ⁽¹⁾

Table 12. Voltage sensing OP Amp AC Characteristics

Note:

(1) Data guaranteed by design.

7.5 SYNC to SVPWM and A/D Conversion AC Timing

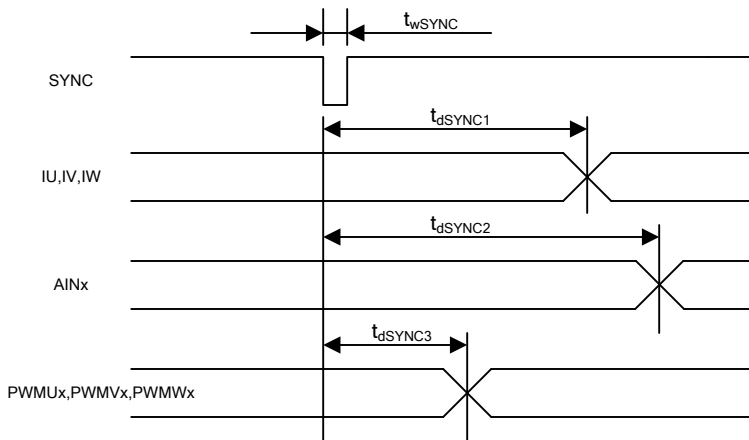

Unless specified, $T_a = 25^\circ C$.

Symbol	Parameter	Min	Typ	Max	Unit
t_{wSYNC}	SYNC pulse width	-	32	-	SYCLK
t_{dSYNC1}	SYNC to current feedback conversion time	-	-	100	SYCLK
t_{dSYNC2}	SYNC to AIN0-6 analog input conversion time	-	-	200	SYCLK ⁽¹⁾
t_{dSYNC3}	SYNC to PWM output delay time	-	-	2	SYCLK

Table 13. SYNC AC Characteristics

Note:

(1) AIN1 through AIN6 channels are converted once every 6 SYNC events

7.6 GATEKILL to SVPWM AC Timing

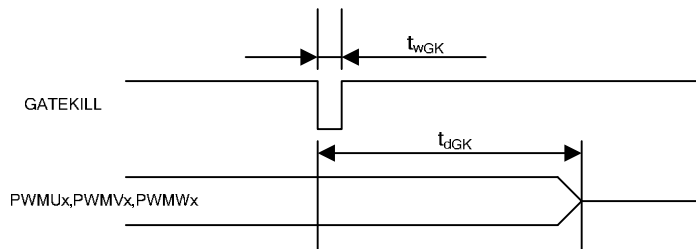

Unless specified, Ta = 25°C.

Symbol	Parameter	Min	Typ	Max	Unit
t_{wGK}	GATEKILL pulse width	32	-	-	SYSCCLK
t_{dGK}	GATEKILL to PWM output delay	-	-	100	SYSCCLK

Table 14. GATEKILL to SVPWM AC Timing

7.7 Interrupt AC Timing

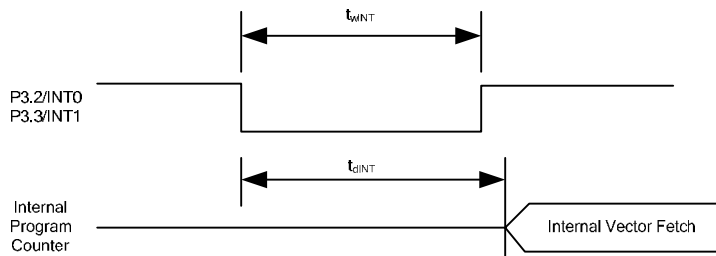

Unless specified, Ta = 25°C.

Symbol	Parameter	Min	Typ	Max	Unit
t_{wINT}	INT0, INT1 Interrupt Assertion Time	4	-	-	SYSCCLK
t_{dINT}	INT0, INT1 latency	-	-	4	SYSCCLK

Table 15. Interrupt AC Timing

7.8 I²C AC Timing

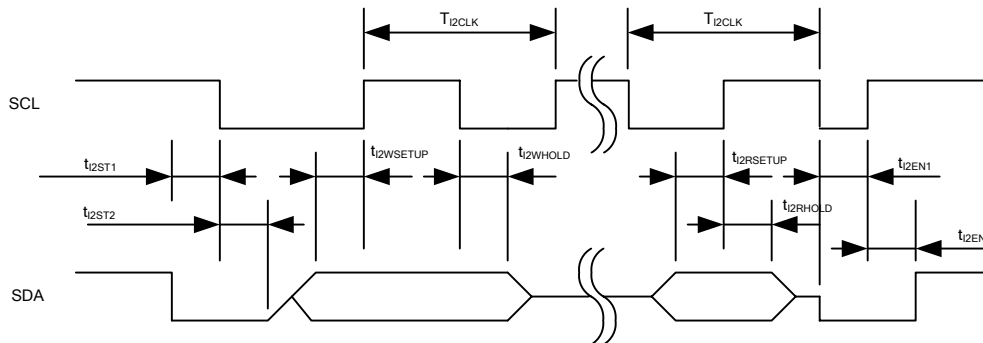

Unless specified, $T_a = 25^\circ\text{C}$.

Symbol	Parameter	Min	Typ	Max	Unit
T_{I2CLK}	I ² C clock period	10	-	8192	SYCLK
t_{I2ST1}	I ² C SDA start time	0.25	-	-	T_{I2CLK}
t_{I2ST2}	I ² C SCL start time	0.25	-	-	T_{I2CLK}
$t_{I2WSETUP}$	I ² C write setup time	0.25	-	-	T_{I2CLK}
$t_{I2WHOLD}$	I ² C write hold time	0.25	-	-	T_{I2CLK}
$t_{I2RSETUP}$	I ² C read setup time	I ² C filter time ⁽¹⁾	-	-	SYCLK
$t_{I2RHOLD}$	I ² C read hold time	1	-	-	SYCLK

Table 16. I²C AC Timing

Note:

- (1) I²C read setup time is determined by the programmable filter time applied to I²C communication.

7.9 SPI AC Timing

7.9.1 SPI Write AC timing

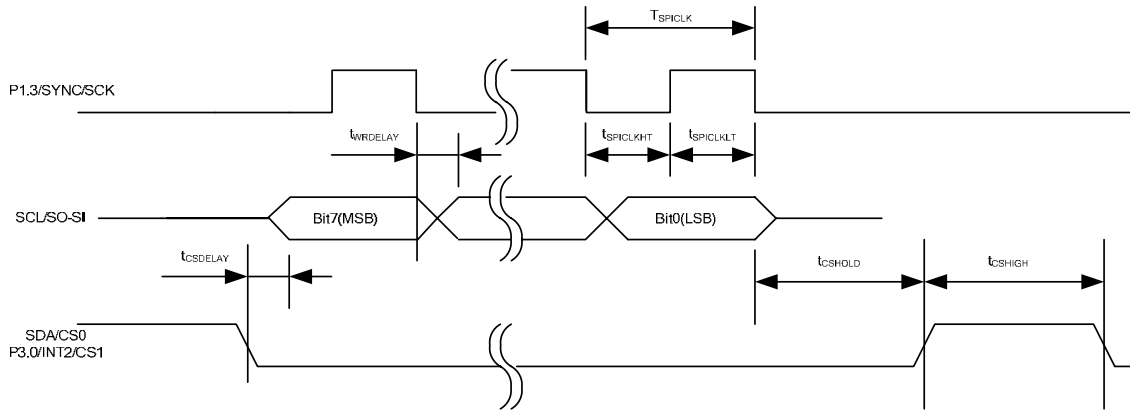

Unless specified, $T_a = 25^\circ\text{C}$.

Symbol	Parameter	Min	Typ	Max	Unit
T_{SPICLK}	SPI clock period	4	-	-	SYSCLK
$t_{SPICLKHT}$	SPI clock high time	-	1/2	-	T_{SPICLK}
$t_{SPICLKLT}$	SPI clock low time	-	1/2	-	T_{SPICLK}
$t_{CSDELAY}$	CS to data delay time	-	-	10	nsec
$t_{WRDELAY}$	CLK falling edge to data delay time	-	-	10	nsec
t_{CSHIGH}	CS high time between two consecutive byte transfer	1	-	-	T_{SPICLK}
t_{CSHOLD}	CS hold time	-	1	-	T_{SPICLK}

Table 17. SPI Write AC Timing

7.9.2 SPI Read AC Timing

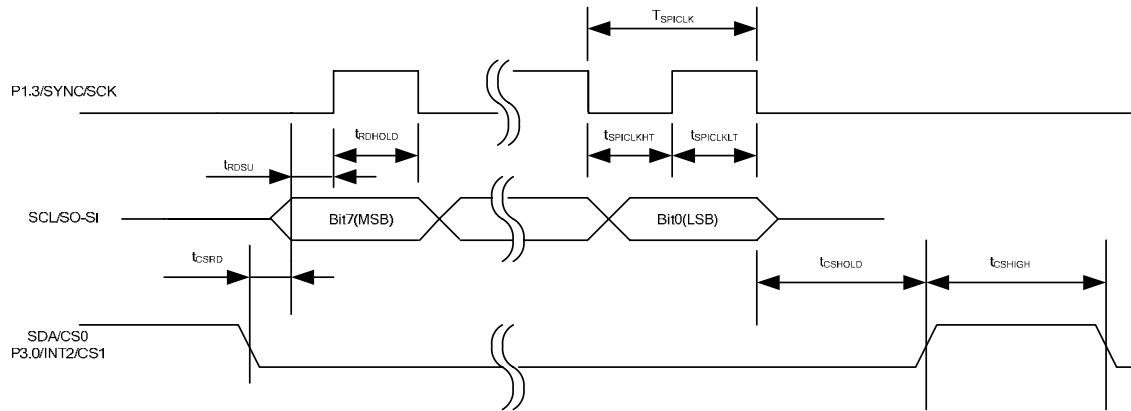

Unless specified, Ta = 25°C.

Symbol	Parameter	Min	Typ	Max	Unit
T _{SPICLK}	SPI clock period	4	-	-	SYSCCLK
t _{SPICLKHT}	SPI clock high time	-	1/2	-	T _{SPICLK}
t _{SPICLKLT}	SPI clock low time	-	1/2	-	T _{SPICLK}
t _{CSRD}	CS to data delay time	-	-	10	nsec
t _{RDSU}	SPI read data setup time	10	-	-	nsec
t _{RDHOLD}	SPI read data hold time	10	-	-	nsec
t _{CSHIGH}	CS high time between two consecutive byte transfer	1	-	-	T _{SPICLK}
t _{CSHOLD}	CS hold time	-	1	-	T _{SPICLK}

Table 18. SPI Read AC Timing

7.10 UART AC Timing

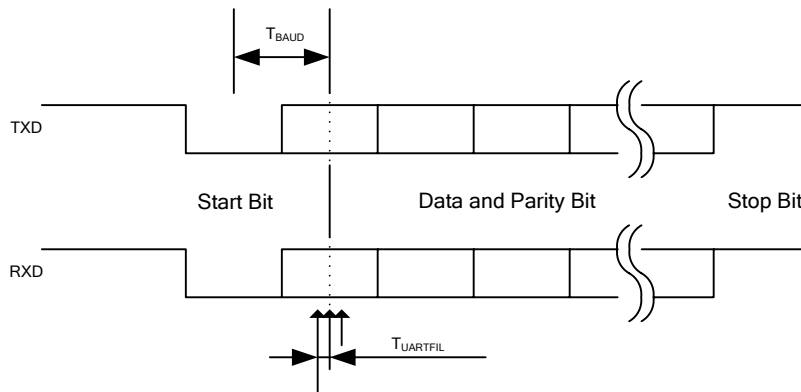

Unless specified, $T_a = 25^\circ\text{C}$.

Symbol	Parameter	Min	Typ	Max	Unit
T_{BAUD}	Baud Rate Period	-	57600	-	bit/sec
$T_{UARTFIL}$	UART sampling filter period ⁽¹⁾	-	1/16	-	T_{BAUD}

Table 19. UART AC Timing

Note:

- (1) Each bit including start and stop bit is sampled three times at center of a bit at an interval of $1/16 T_{BAUD}$. If three sampled values do not agree, then UART noise error is generated.

7.11 CAPTURE Input AC Timing

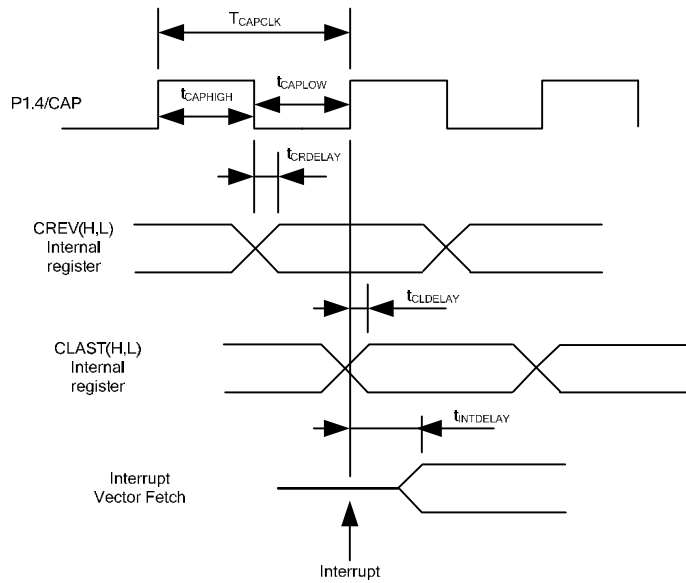

Unless specified, $T_a = 25^\circ\text{C}$.

Symbol	Parameter	Min	Typ	Max	Unit
T_{CAPCLK}	CAPTURE input period	8	-	-	SYSCCLK
$t_{CAPHIGH}$	CAPTURE input high time	4	-	-	SYSCCLK
t_{CAPLOW}	CAPTURE input low time	4	-	-	SYSCCLK
$t_{CRDELAY}$	CAPTURE falling edge to capture register latch time	-	-	4	SYSCCLK
$t_{CLDELAY}$	CAPTURE rising edge to capture register latch time	-	-	4	SYSCCLK
$t_{INTDELAY}$	CAPTURE input interrupt latency time	-	-	4	SYSCCLK

Table 20. CAPTURE AC Timing

7.12 JTAG AC Timing

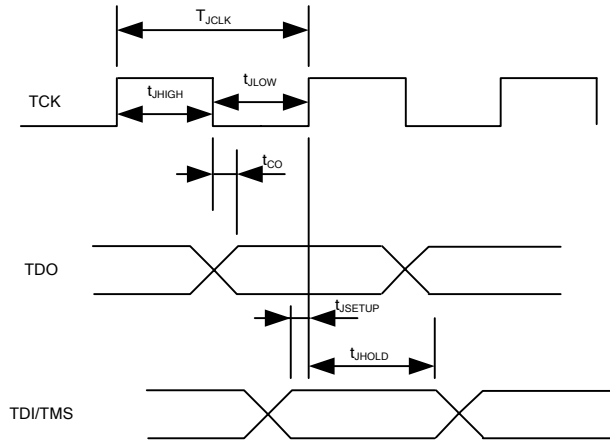

Unless specified, $T_a = 25^\circ\text{C}$.

Symbol	Parameter	Min	Typ	Max	Unit
T_{JCLK}	TCK Period	-	-	50	MHz
t_{JHIGH}	TCK High Period	10	-	-	nsec
t_{JLOW}	TCK Low Period	10	-	-	nsec
t_{CO}	TCK to TDO propagation delay time	0	-	5	nsec
t_{JSETUP}	TDI/TMS setup time	4	-	-	nsec
t_{JHOLD}	TDI/TMS hold time	0	-	-	nsec

Table 21. JTAG AC Timing

8 Pin List

Pin Number	Pin Name	Internal IC Pull-up /Pull-down	Pin Type	Description
1	XTAL0		I	Crystal input
2	XTAL1		O	Crystal output
3	P1.0/T2		I/O	Discrete programmable I/O or Timer/Counter 2 input
4	P1.1/RXD		I/O	Discrete programmable I/O or UART receive input
5	P1.2/TXD		I/O	Discrete programmable I/O or UART transmit output
6	P1.3/SYNC/ SCK		I/O	Discrete programmable I/O or SYNC output or SPI clock output, needs to be pulled up to VDD1 in order to boot from I ² C EEPROM
7	P1.4/CAP		I/O	Discrete programmable I/O or Capture Timer input
8	P1.5		I/O	Discrete programmable I/O
9	P1.6		I/O	Discrete programmable I/O
10	P1.7		I/O	Discrete programmable I/O
11	P4.3/INT6		I/O	Discrete programmable I/O or Interrupt 6
12	P4.7/INT10		I/O	Discrete programmable I/O or Interrupt 10
13	VDD2		P	1.8V digital power
14	VSS		P	Digital common
15	VDD1		P	3.3V digital power
16	FGATEKILL		I	Fan PWM shutdown input, 2- μ sec digital filter, configurable either high or low true.
17	FPWMWL	70 k Ω Pull up	O	Fan PWM gate drive for phase W low side, configurable either high or low true
18	FPWMWH	70 k Ω Pull up	O	Fan PWM gate drive for phase W high side, configurable either high or low true
19	FPWMVL	70 k Ω Pull up	O	Fan PWM gate drive for phase V low side, configurable either high or low true
20	FPWMVH	70 k Ω Pull up	O	Fan PWM gate drive for phase V high side, configurable either high or low true
21	FPWMUL	70 k Ω Pull up	O	Fan PWM gate drive for phase U low side, configurable either high or low true
22	FPWMUH	70 k Ω Pull up	O	Fan PWM gate drive for phase U high side, configurable either high or low true
23	P2.0/NMI		I/O	Discrete programmable I/O or Non Maskable Interrupt
24	P2.1		I/O	Discrete programmable I/O
25	P2.2		I/O	Discrete programmable I/O
26	P2.3		I/O	Discrete programmable I/O

Pin Number	Pin Name	Internal IC Pull-up /Pull-down	Pin Type	Description
27	P2.4		I/O	Discrete programmable I/O
28	P2.5		I/O	Discrete programmable I/O
29	P2.6/ AOPWM0		I/O	Discrete programmable I/O or analog output 0 (PWM)
30	P2.7/ AOPWM1		I/O	Discrete programmable I/O or analog output 1 (PWM)
31	VDD2		P	1.8V digital power
32	VSS		P	Digital common
33	VSS		P	Digital common
34	VDD1		P	3.3 V digital power
35	P4.0/INT3		I/O	Discrete programmable I/O or Interrupt 3
36	P4.4/INT7		I/O	Discrete programmable I/O or Interrupt 7
37	IFBF-		I	Fan single shunt current sensing OP amp input (-)
38	IFBF+		I	Fan single shunt current sensing OP amp input (+)
39	IFBFO		O	Fan single shunt current sensing OP amp output
40	AIN0/VDCO		O	Analog input channel 0 or DC bus voltage sensing OP amp output
41	VDC+		I	DC bus voltage sensing OP amp input (+)
42	VDC-		I	DC bus voltage sensing OP amp input (-)
43	AVDD		P	Analog power (1.8V)
44	AVSS		P	Analog common
45	AIN1		I	Analog input channel 1, 0-1.2V range, needs to be pulled down to AVSS if unused
46	CMEXT		O	Unbuffered analog reference voltage output (0.6V)
47	AREF		O	Analog reference voltage output (0.6V)
48	IFBC-		I	Compressor single shunt current sensing OP amp input (-)
49	IFBC+		I	Compressor single shunt current sensing OP amp input (+)
50	IFBCO		O	Compressor single shunt current sensing OP amp output
51	DNC		-	Do not connect.
52	AIN2		I	Analog input channel 2, 0-1.2V range, needs to be pulled down to AVSS if unused
53	AIN3		I	Analog input channel 2, 0-1.2V range, needs to be pulled down to AVSS if unused
54	AIN4		I	Analog input channel 2, 0-1.2V range, needs to be pulled down to AVSS if unused
55	AIN5		I	Analog input channel 2, 0-1.2V range, needs to be pulled down to AVSS if unused

Pin Number	Pin Name	Internal IC Pull-up /Pull-down	Pin Type	Description
56	AIN6		I	Analog input channel 2, 0-1.2V range, needs to be pulled down to AVSS if unused
57	VAC+		I	AC input voltage sensing OP amp input (+)
58	VAC-		I	AC input voltage sensing OP amp input (-)
59	VACO		O	AC input voltage sensing OP amp output
60	IPFCO		O	PFC shunt current sensing OP amp output
61	IPFC+		I	PFC shunt current sensing OP amp input (+)
62	IPFC-		I	PFC shunt current sensing OP amp input (-)
63	P4.5/INT8		I/O	Discrete programmable I/O or Interrupt 8
64	P4.1/INT4		I/O	Discrete programmable I/O or Interrupt 4
65	VDD2		P	1.8 V digital power
66	VSS		P	Digital common
67	VDD1		P	3.3V digital power
68	CGATEKILL		I	Compressor PWM shutdown input, 2- μ sec digital filter, configurable either high or low true.
69	CPWMWL	70 k Ω Pull up	O	Compressor PWM gate drive for phase W low side, configurable either high or low true
70	CPWMWH	70 k Ω Pull up	O	Compressor PWM gate drive for phase W high side, configurable either high or low true
71	CPWMVL	70 k Ω Pull up	O	Compressor PWM gate drive for phase V low side, configurable either high or low true
72	CPWMVH	70 k Ω Pull up	O	Compressor PWM gate drive for phase V high side, configurable either high or low true
73	CPWMUL	70 k Ω Pull up	O	Compressor PWM gate drive for phase U low side, configurable either high or low true
74	CPWMUH	70 k Ω Pull up	O	Compressor PWM gate drive for phase U high side, configurable either high or low true
75	P3.0/INT2/ CS1		I/O	Discrete programmable I/O or INT2 digital input or SPI Chip Select 1
76	P5.0/ PFCGKILL		I	Discrete programmable I/O or PFC PWM shutdown input, 2- μ sec digital filter, configurable either high or low true.
77	PFCPWM	70 k Ω Pull up	O	PFC PWM gate drive, configurable either high or low true
78	P3.1/ AOPWM2		I/O	Discrete programmable I/O or analog output 2 (PWM)
79	P3.2/INT0		I/O	Discrete programmable I/O or external interrupt 0
80	P3.3/INT1		I/O	Discrete programmable I/O or external interrupt 1
81	P3.4/T0		I/O	Discrete programmable I/O or Timer/Counter 0 input

Pin Number	Pin Name	Internal IC Pull-up /Pull-down	Pin Type	Description
82	P3.5/T1		I/O	Discrete programmable I/O or Timer/Counter 1 input
83	P3.6/RXD1		I/O	Discrete programmable I/O or 2 nd UART receive input
84	P3.7/TXD1		I/O	Discrete programmable I/O or 2 nd UART transmit output
85	VSS		P	Digital common
86	VSS		P	Digital common
87	VDD1		P	3.3V digital power
88	P4.2/INT5		I/O	Discrete programmable I/O or Interrupt 5
89	P4.6/INT9		I/O	Discrete programmable I/O or Interrupt 9
90	SCL/SO-SI		I/O	I ² C clock output or SPI data
91	SDA/CS0		I/O	I ² C data or SPI Chip Select 0
92	P5.1/TMS		I/O	Discrete programmable I/O or JTAG test mode select
93	P5.2/TDO		I/O	Discrete programmable I/O or JTAG port test data output
94	P5.3/TDI		I/O	Discrete programmable I/O or JTAG test data input
95	TCK		I	JTAG test clock
96	TSTMOD	58 kΩ pull down	I	Test mode. Must be tied to VSS. Factory use only
97	RESET		I/O	Reset, low true, Schmitt trigger input
98	VDD2		P	1.8V digital power
99	PLLVDD		P	1.8V PLL power.
100	PLLVSS		P	PLL ground.

Table 22. Pin List

9 Package Dimensions

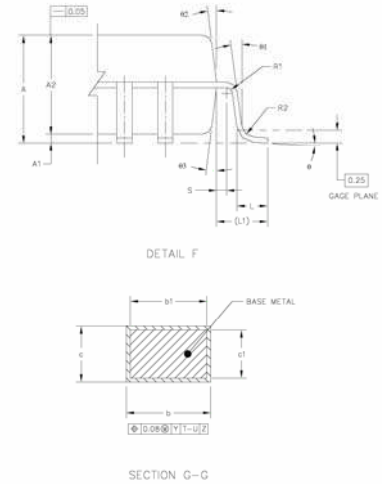
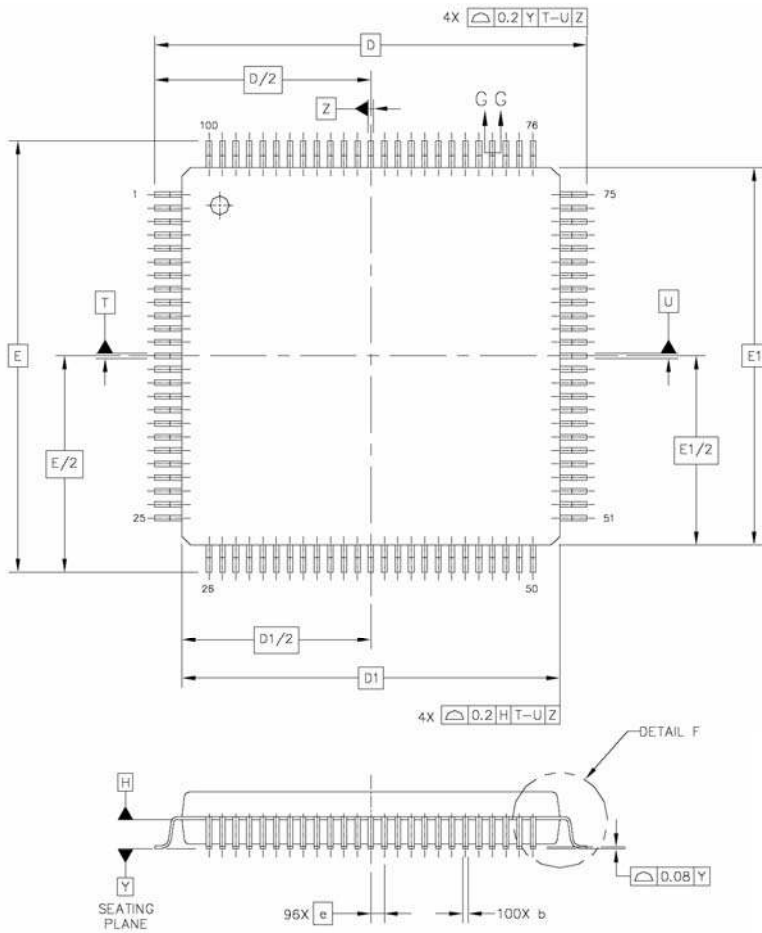

NOTES:

1. DIMENSIONS D1 AND E1 DO NOT INCLUDE MOLD PROTRUSION, ALLOWABLE PROTRUSION IS 0.25mm PER SIDE, DIMENSIONS D1 AND E1 ARE MAXIMUM PLASTIC BODY SIZE DIMENSIONS INCLUDING MOLD MISMATCH.
2. DIMENSION b DOES NOT INCLUDE DAMBAR PROTRUSION, ALLOWABLE DAMBAR PROTRUSION SHALL NOT CAUSE THE LEAD WIDTH TO EXCEED THE MAXIMUM b DIMENSION BY MORE THAN 0.08mm. DAMBAR CANNOT BE LOCATED ON THE LOWER RADIUS OR THE FOOT. MINIMUM SPACE BETWEEN PROTRUSION AND AN ADJACENT LEAD IS 0.07mm FOR 0.4mm AND 0.5mm PITCH PACKAGES.

DIM	MIN	NOM	MAX	DIM	MIN	NOM	MAX	DIM	MIN	NOM	MAX
A	---		1.6	L1		1 REF					
A1	0.05		0.15	R1	0.08		---				
A2	1.35	1.4	1.45	R2	0.08		0.2				
b	0.17	0.2	0.27	S	0.2		---				
b1	0.17		0.23	θ	0°	3.5°	7°				
c	0.09		0.2	θ1	0°		---				
c1	0.09		0.16	θ2	11°	12°	13°				
D		16 BSC		θ3	11°	12°	13°				
D1		14 BSC									
e		0.5 BSC									
E		16 BSC									
E1		14 BSC									
L	0.45	0.6	0.75								
			UNIT			DIMENSION AND TOLERANCES			REFERENCE DOCUMENT		
			MM			ASME Y14.5M			64-06-A000-PT03-C		
TITLE: LQFP 100 LD 14X14X1.4 PKG 0.5 PITCH POD 2mm FOOTPRINT (JEDEC)											

10 Part Marking Information

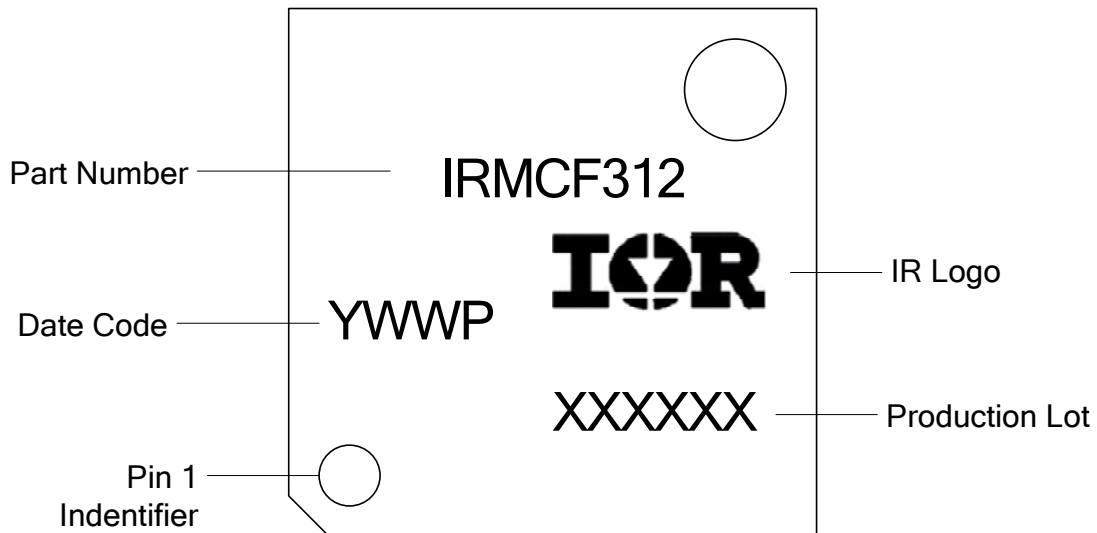

Order Information

Lead-Free Part in 64-lead QFP
Moisture sensitivity rating – MSL3

Part number	Order quantities
IRMCF312TR	1000 parts on tape and reel in dry pack

International
IR Rectifier

The LQFP-100 is MSL3 qualified
 This product has been designed and qualified for the industrial level
 Qualification standards can be found at www.irf.com <<http://www.irf.com>>
 IR WORLD HEADQUARTERS: 233 Kansas St., El Segundo, California 90245, Tel: (310) 252-7105
 Data and specifications subject to change without notice. 12/05/2006