

**QUARTZ CRYSTAL UNIT SPECIFICATION**

- ELECTRICAL CHARACTERISTICS**

CUSTOMER	
CUSTOMER P/N	
“NKG” PART NUMBER	<b>01-CR1-02-16M9344-32-1515-NS1</b>
PACKAGE TYPE (SEE DWG BELOW)	HC-49/S
NOMINAL FREQUENCY:	16.934400MHz
MODEL OF OSCILLATION	FUNDAMENTAL
CRYSTAL CUT	AT-Cut
FREQUENCY TOLERANCE:	±15ppm (Ref at 25°C±2°C)
TEMPERATURE STABILITY	±15ppm
OPERATION TEMPERATURE:	-40 °C to +85 °C
STORAGE TEMPERATURE	-55 °C to +125 °C
LOAD CAPACITANCE	32pF
SHUNT CAPACITANCE C0	7pF MAX
EQUIVALENT SERIES RESISTANCE	ESR = 50 Ω MAX
DRIVE LEVEL:	100μW TYP – 500μW MAX
AGING RATE FIRST YEAR:	± 5ppm / Year
INSULATION RESISTANCE:	500 MΩ MIN; at 100VDC
TEST IMPEDANCE METER:	KOLINKER KH1200 / IEC444
RoHS COMPLIANCE	COMPLIANT

NOTES: NONE

- MARKING**

**NKG**16.93:J30

NKG LOGO + FREQUENCY + YEAR AND WEEK CODE

YEAR CODE = J: YEAR 2009; K: YEAR 2010; L: YEAR 2011

WEEK CODE = WORK WEEK NUMBER

● **MECHANICAL DIMENSIONS**

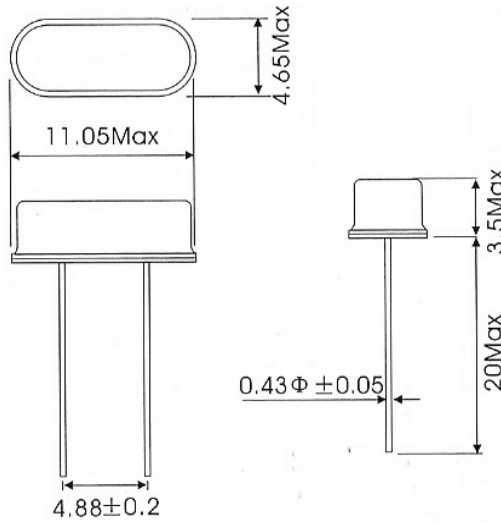

● **RELIABILITY TESTS**

TEST	CONDITONS	CRITERIA
1. High Temperature Storage	24 hours @105°C ±5°C 6 hours resting before electrical test	ΔF , ±5ppm ΔR > ±5Ω
2. Low Temperature Storage	24 hours @-30°C ±5°C 6 hours resting before electrical test	ΔF , ±5ppm ΔR > ±5Ω
3. Shock Test (Drop Test)	3 times drop from 75cm height onto 3cm thick hard wood board	ΔF , ±5ppm ΔR > ±5Ω
4. Aging	168 hours @105°C ±5°C 6 hours resting before electrical test	ΔF , ±5ppm ΔR > ±5Ω
5. Solderability	After flux dip, for 5s ±0.5s Solder bath @+2450°C ±5°C	95% solder coverage
6. Exposure to Solder Heat	3 times reflow @260°C ±5°C for 10s MIN; 2 hours resting before electrical test	ΔF , ±5ppm ΔR > ±5Ω
7. Lead Pull Test	Pull crystal leads for 10s ±1s with weight of 0.5kg, Leak test	No leakages ΔF , ±5ppm ΔR > ±5Ω
8. Lead bending Test	3 times 90° lead bending using weight 0.25kg, remain 2~3s Leak test	No leakages

- **PACKAGING**

Dimensions of Inner Box (units: mm)

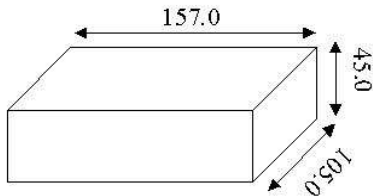

**Bulk pack**

1 Inner Box = 1,000pcs

Dimensions of Carton (units: mm)

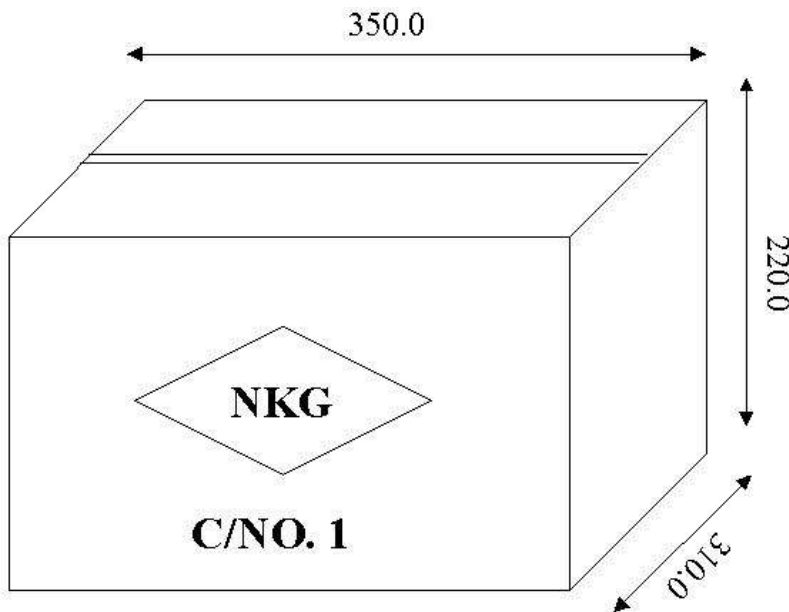

1 Carton = 20 inner box

1 Carton = 20,000pcs

Prepared by: <i>N.Wong</i>	Approved by: <i>M.Bruech</i>	Release date: <i>2009/07/30</i>	Revision: <b>A</b>
-------------------------------	---------------------------------	------------------------------------	-----------------------