

NOTES:

1. FOR WAVESOLDERING (SOLDER BATH TEMPERATURE 240°C FOR 5 SEC. AND SOLDER PREHEAT 120°C FOR 120 SEC.)
2. METALSHELLS: COPPER ALLOY; min. 315µin TIN over 40-80µin NICKEL
3. INSULATORS: PBT GF UL 94 V-0; GREEN
4. SIGNAL CONTACTS: COPPER ALLOY
PLATING: GOLD FLASH over NICKEL
5. HIGH POWER CONTACTS 20A: COPPER ALLOY
PLATING, MATING AREA: GOLD FLASH over NICKEL
PLATING, TERMINATION SIDE: 160-240µin TIN over 80µin NICKEL
6. THREADED SPACER CLIPS: COPPER ALLOY;
min. 200µin TIN over 80µin NICKEL
PCB-HOLE: Ø3,1±0,1; PCB THICKNESS 1,6mm
7. COLLARS: COPPER ALLOY; min. 200µin TIN over 80µin NICKEL
8. HEXLOCKING SCREWS: STAINLESS STEEL
9. FRAME: ZINC DIE CAST; NICKEL PLATED
10. O-RING: SILICON; BLUE
11. RUBBER-GASKET: TPE; BLACK
12. SEALING COMPOUND: PUR; BLUE
13. P.C.B. HOLE DRILLINGS AND RECOMMENDED PANEL CUT-OUT ON SHEET 2
14. RECOMMENDED TORQUE FOR MOUNTING SCREW
35Ncm (3.1 in.LB) / max. 40Ncm (3,5 in.LB)
15. CONNECTOR IS PART MARKED: 6007W2PAR68E20X CONEC ABC

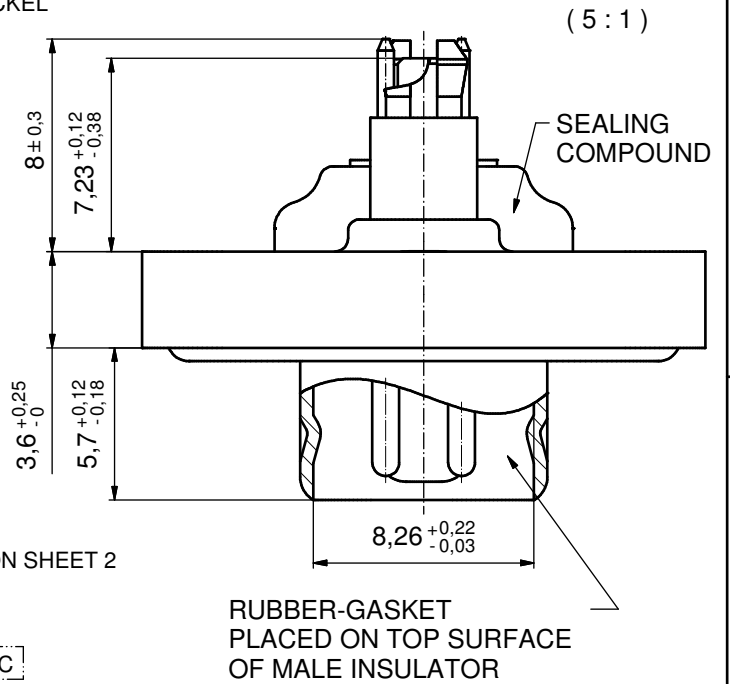

AT ALL TIMES WATER RESISTANT CONNECTORS NOT IN USE SHOULD BE COVERED WITH A CONEC WATER RESISTANT CAP OR WATER TIGHT HOOD.

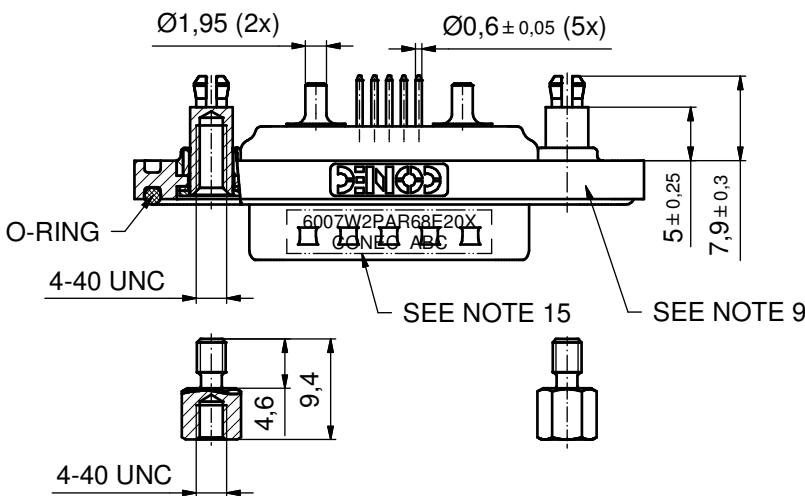
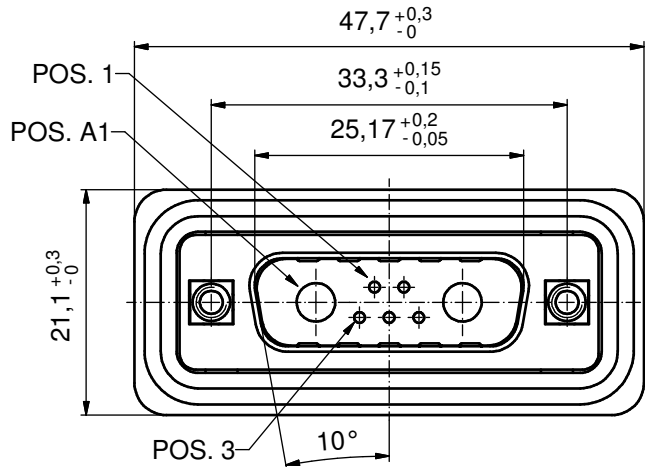
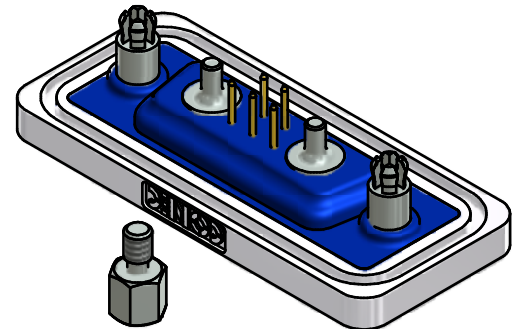

Directive 2002/95/EC RoHS compliant

THIS DRAWING MAY NOT BE COPIED OR REPRODUCED IN ANY WAY, AND MAY NOT BE PASSED ON TO A THIRD PARTY WITHOUT WRITTEN PERMISSION. OWNERSHIP AND COPYRIGHT OF CONEC GmbH DO NOT ALTER CAD DRAWING BY HAND	tolerance		dim. in mm		scale: 2:1 (5:1)	
					material: SEE NOTES	
	drawn	03.07.14	name		title:	
	appd.	04.07.14	Lehmenkühler		D-SUB COMBINATION MALE	
	norm		d-old		7W2P	
	rev.	a	description	Original	dwg no:	
					15K1A1515	
					part no: 6007W2PAR68E20X	
					DIN-A3	
					sh: 1/2	



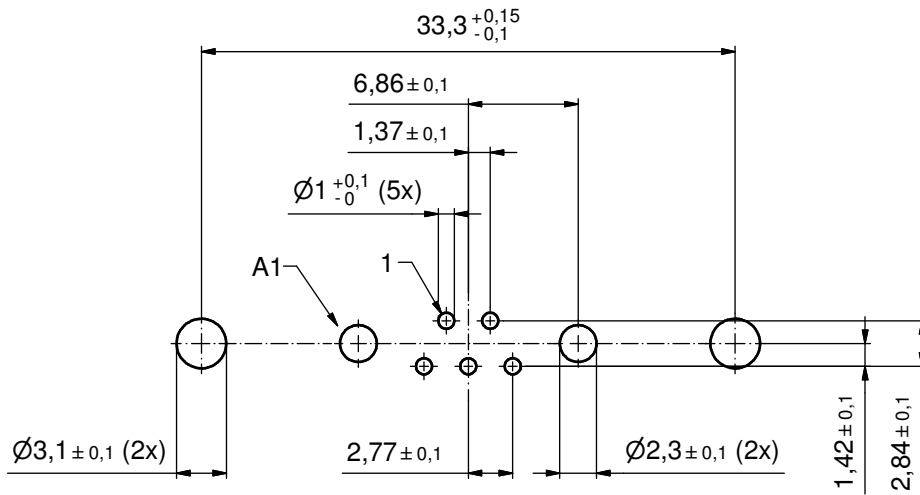

P.C.B. HOLE DRILLINGS
(P.C.B. TOP SIDE)

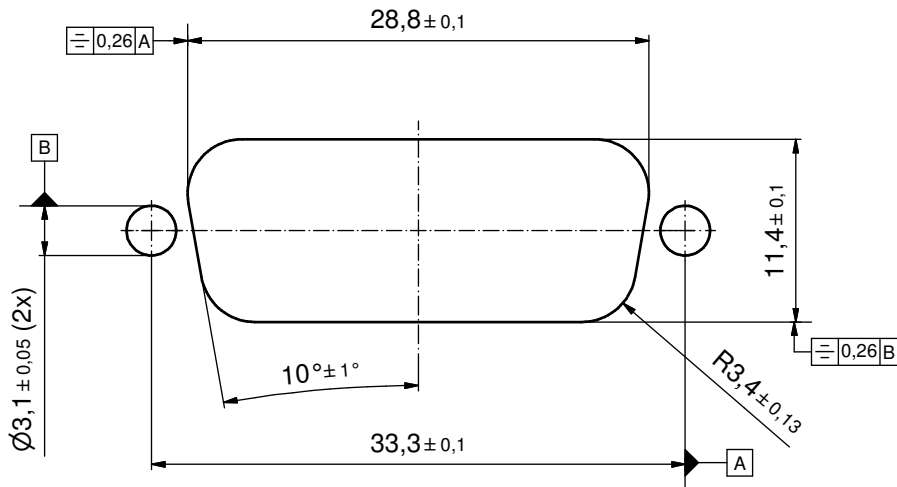

RECOMMENDED PANEL CUT-OUT

THIS DRAWING MAY NOT BE COPIED OR REPRODUCED IN ANY WAY, AND MAY NOT BE PASSED ON TO A THIRD PARTY WITHOUT WRITTEN PERMISSION. OWNERSHIP AND COPYRIGHT OF CONEC GmbH DO NOT ALTER CAD DRAWING BY HAND				tolerance		scale: 3:1
				dim. in mm		material: SEE SHEET 1
				date	name	title:
				drawn	03.07.14 Henneboel	P.C.B. HOLE DRILLINGS RECOMMENDED PANEL CUT-OUT D-SUB COMBINATION MALE 7W2P
				appd.	04.07.14 Lehmenkühler	
			norm		dwg no:	
			d-old		DIN-A3	
			a	Original	15K1A1515	sh: 2/2
			rev.	description	date	name
			CONEC [®]			part no: SEE SHEET 1