

LDW480 Series

480 W Wide Input Range
DIN Rail Power Supply

LDW480 Series are single, two or three phase wide input range DIN rail power supplies with active PFC.

Its compact size, high efficiency, excellent reliability together with easy installation makes it ideal for various industrial, telecom and renewable energy applications.

LDW480 Series are Class I isolation devices and are designed to be mounted on DIN rail and installed inside a protective enclosure.



FEATURES

- Single, two or three phase AC input 187 - 550 VAC or wide DC input voltage range 250 - 725 VDC
- Output voltages 24 V, 48 V, 72 V (adjustable)
- Operating ambient temperature range -40°C to +70°C
- Efficiency up to 92%
- Active PFC
- Overload 140%
- Excellent field reliability record
- Compact size in aluminum enclosure
- Dimensions: 73 x 140 x 125 mm



APPLICATIONS

- Industrial control equipment
- Telecom
- Renewable energy applications

1. MODEL SELECTION

MODEL	INPUT VOLTAGE RANGE	# OF PHASES	OUTPUT VOLTAGE	MAX OUTPUT CURRENT	EFFICIENCY	MAX OUTPUT POWER
LDW480-24	200 - 500 VAC (250 - 725 VDC)	1 / 2 / 3	24 V	20 A	92 %	480 W
LDW480-48	200 - 500 VAC (250 - 725 VDC)	1 / 2 / 3	48 V	10 A	92 %	480 W
LDW480-72	200 - 500 VAC (250 - 725 VDC)	1 / 2 / 3	72 V	6 A	91 %	480 W

Discontinued model

2. INPUT SPECIFICATIONS

PARAMETER	DESCRIPTION / CONDITIONS	SPECIFICATION
AC Input Voltage	Nominal 1 / 2 / 3 phases (UL certified) Range	200 - 500 VAC 187 - 550 VAC
DC Input Voltage		250 - 725 VDC
Input Frequency	1 / 2 / 3 phases 1 / 2 phases only	47 - 63 Hz 400 Hz
AC Input Current	Vin = 200 VAC 1 / 2 phases 3 phases	2.9 A 1.8 A
	Vin = 500 VAC 1 / 2 phases 3 phases	1.3 A 0.8 A
DC Input Current	Vin = 250 VDC	2.1 A
	Vin = 725 VDC	0.8 A
Power Factor Correction	Active	> 0.9
Inrush Peak Current I _{pt}	Peak Current measured after 0.2 ms from main connection; 400 VAC / 50 Hz; Ta = 25°C; Cold Start	≤ 55 A 2.16 A ² s
Touch (Leakage) Current		≤ 0.6 mA
Internal Protection Fuse	None, external fuse must be provided	
Recommended External Protection	It is strongly recommended to provide external surge arresters (SPD) according to local regulations.	Fuse 6.3 AT or MCB 6 A C curve or MCB 4 A D curve

3. OUTPUT SPECIFICATIONS

PARAMETER	DESCRIPTION / CONDITIONS	SPECIFICATION
Output Voltage (Adjustable)	24 V model	23 - 28 VDC
	48 V model	45 - 55 VDC
	72 V model	72 - 85 VDC
Output Current (Continuous)	24 V model	20 A
	48 V model	10 A
	72 V model	6 A
Load Regulation		≤ 1.0 %
Ripple & Noise ²	24 V model	≤ 50 mVpp
	48 V & 72 V models	≤ 100 mVpp
Hold-up Time		≥ 50 ms
Status Signals	DC OK - green LED OVERLOAD - red LED DC OK - dry contact (NO, 24 VDC / 1 A)	
Parallel Connection	Possible for redundancy (with external ORing module)	

² Ripple and Noise are measured with 20 MHz bandwidth, probe terminated with a 0.1 μF MKP parallel capacitor.

4. PROTECTIONS

PARAMETER	DESCRIPTION / CONDITIONS	SPECIFICATION	
Short Circuit Protection	Hiccup mode, Short Circuit Peak Current:	24 V model	50 A
		48 V model	25 A
		72 V model	12 A
Overload Protection	Hiccup mode, Overload Limit:	24 V model	28 A
		48 V model	14 A
		72 V model	9 A
Thermal Protection			
Over Voltage Protection		24 V model	≥ 33 VDC
		48 V model	≥ 68 VDC
		72 V model	≥ 100 VDC

5. ENVIRONMENTAL, EMC & SAFETY SPECIFICATIONS

PARAMETER	DESCRIPTION / CONDITIONS	SPECIFICATION
Operating Temperature	UL certified up to 45°C Start-up type tested: - 40°C, possible at Vnom with load deration.	-40 to +70 °C
Storage Temperature		-40 to +80 °C
Derating	Over 45°C	- 10 W/°C
Dissipated Power	24 V & 48 V models	< 42.0 W
	72 V models	< 42.5 W
Humidity	Non-condescending	5 - 95 % RH
Life Time Expectancy	Ta = 25°C, full load	65 496 (7.4) hrs (years)
MTBF	MIL-HDBK-217F at Ta = 25°C, full load	> 500 000 hrs
Overvoltage Category	EN 50178	III
Pollution Degree	IEC 60664-1	2
Protection Class	Class I	
Isolation	Input to Output	4.2 kVDC
	Input to Ground	2.2 kVDC
	Output to Ground	0.75 kVDC
Safety Standards & Approvals	UL 508 (certified)	
	IEC/EN 61010-1	
	IEC/EN 61010-2-201	
	IEC/EN 60950	
EMC Emissions	EN 55011 / CISPR 11	Class A
	EN 61000-3-2	Class A
EMC Immunity	EN 61000-4-2	Level 3
	EN 61000-4-3	Level 3
	EN 61000-4-4	Level 4
	EN 61000-4-5	Level 3
	EN 61000-4-11	Level 2
Protection Degree	EN 60529	IP20
Vibration Sinusoidal	IEC 60068-2-6	5 - 17.8 Hz: ±1.6 mm; 17.8 - 500 Hz: 2 g 2 hours / axis (X,Y, Z)
Shock	IEC 60068-2-27	30 g 6 ms, 20 g 11 ms; 3 bumps / direction, 18 bumps total

6. MECHANICAL SPECIFICATIONS

PARAMETER	DESCRIPTION / CONDITIONS	SPECIFICATION
Dimensions		73 x 140 x 125 mm 2.87 x 5.51 x 4.92 in
Weight		1000 g
Mounting Rail	IEC 60715/H15/TH35-7.5(-15)	
Connection Terminals	Screw type pluggable (24 - 12 AWG)	2.5 mm ²
Case Material	Aluminum	

7. PIN LAYOUT & DESCRIPTION

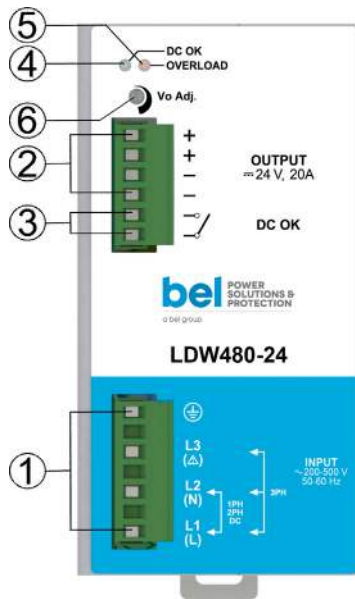

PIN DESCRIPTION

PIN	DESCRIPTION
1	AC/DC input
2	DC output (load)
3	Diagnostic Output (dry contact, NC output OK)
4	Green LED: Output OK
5	Red LED: Overload
6	Output voltage adjustment

INPUT CONNECTION	Single-phase	Two-phase
	L = Line N = Neutral ⊕ = Earth ground	L1 = Phase 1 L2 = Phase 2 ⊕ = Earth ground
	Three-phase	DC Input
	L1 = Phase 1 L2 = Phase 2 L3 = Phase 3 ⊕ = Earth ground	L1(L) = + Positive DC L2(N) = - Negative DC L3 = do not connect ⊕ = Earth ground

OUTPUT CONNECTION	
	+ = Positive DC - = Negative DC

SIGNALLING	
	DC OK: dry contact • NO • COM

8. MECHANICAL DRAWING

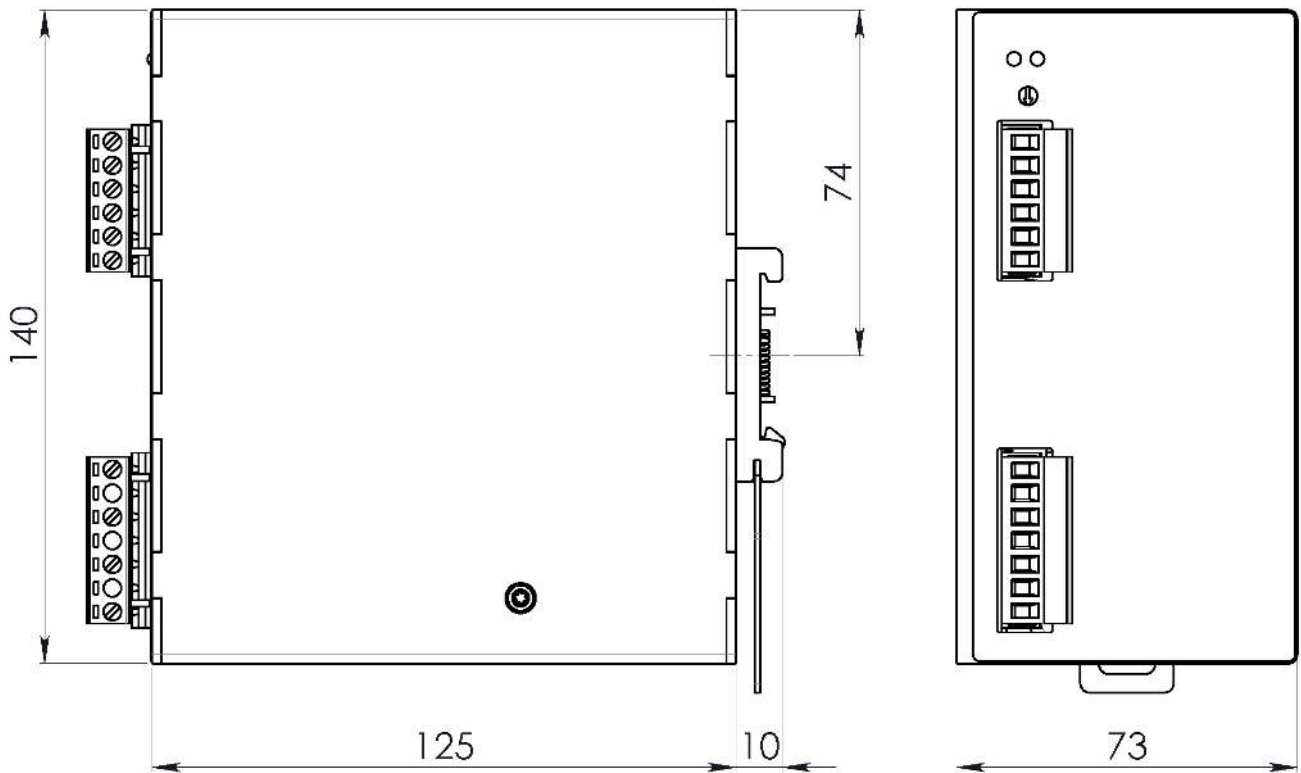

Figure 1. Mechanical Drawing

Notes:

Technical parameters are typical, measured in laboratory environment at 25°C and 400 VAC / 50 Hz, at nominal values, after minimum 5 minutes of operation. Power rating, losses, efficiency, ripple, thermal behaviour and start-up may change outside of the nominal rated input range. Contact factory for details.

NUCLEAR AND MEDICAL APPLICATIONS - Products are not designed or intended for use as critical components in life support systems, equipment used in hazardous environments, or nuclear control systems.

TECHNICAL REVISIONS - The appearance of products, including safety agency certifications pictured on labels, may change depending on the date manufactured. Specifications are subject to change without notice.