



### Description

The ICS651 is a low skew, single input to four output, clock buffer. Part of ICS' ClockBlocks™ family, this is a low skew, small clock buffer.

ICS makes many non-PLL and PLL based low skew output devices as well as Zero Delay Buffers to synchronize clocks. Contact us for all of your clocking needs.

### Features

- Low skew outputs (250 ps)
- Packaged in 8-pin SOIC
- Available in Pb (lead) free package
- Low power CMOS technology
- Operating Voltages of 1.8 V to 2.5 V
- Output Enable pin tri-states outputs
- 3.3 V tolerant input clock
- Industrial temperature range

### Block Diagram

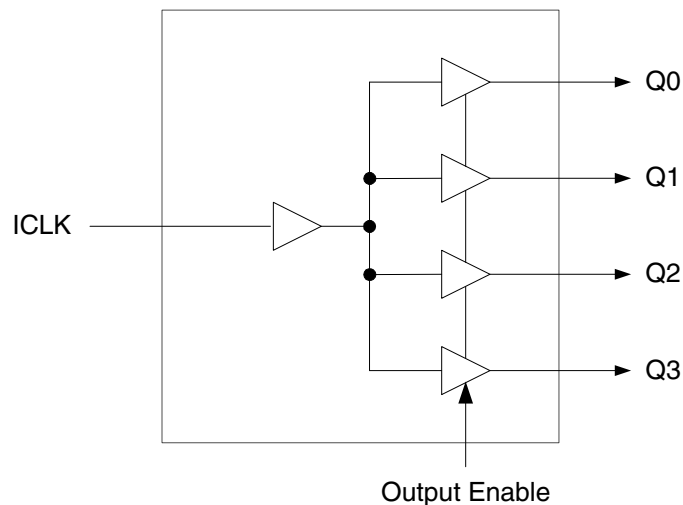



## Pin Assignment

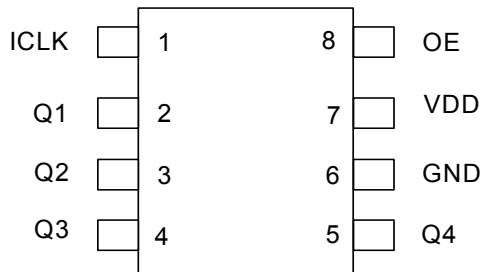

## Pin Descriptions

Pin Number	Pin Name	Pin Type	Pin Description
1	ICLK	Input	Clock Input. 3.3 V tolerant input.
2	Q1	Output	Clock Output 1.
3	Q2	Output	Clock Output 2.
4	Q3	Output	Clock Output 3.
5	Q4	Output	Clock Output 4.
6	GND	Power	Connect to ground.
7	VDD	Power	Connect to +1.8 V or +2.5 V.
8	OE	Input	Output Enable. Tri-states outputs when low. Connect to VDD for normal operation.

## External Components

A minimum number of external components are required for proper operation. A decoupling capacitor of 0.01  $\mu$ F should be connected between VDD on pin 7 and GND on pin 6, as close to the device as possible. A 33  $\Omega$  series terminating resistor may be used on each clock output if the trace is longer than 1 inch.

To achieve the low output skew that the ICS651 is capable of, careful attention must be paid to board layout. Essentially, all four outputs must have identical terminations, identical loads and identical trace geometries. If they do not, the output skew will be degraded. For example, using a 30 $\Omega$  series termination on one output (with 33 $\Omega$  on the others) will cause at least 15 ps of skew.



## Absolute Maximum Ratings

Stresses above the ratings listed below can cause permanent damage to the ICS651. These ratings, which are standard values for ICS commercially rated parts, are stress ratings only. Functional operation of the device at these or any other conditions above those indicated in the operational sections of the specifications is not implied. Exposure to absolute maximum rating conditions for extended periods can affect product reliability. Electrical parameters are guaranteed only over the recommended operating temperature range.

Item	Rating
Supply Voltage, VDD	7 V
Output Enable and All Outputs	-0.5 V to VDD+0.5 V
ICLK	-0.5 V to 3.6 V (VDD > 0V)
Ambient Operating Temperature	-40 to +85 °C
Storage Temperature	-65 to +150°C
Junction Temperature	125°C
Soldering Temperature	260°C

## Recommended Operation Conditions

Parameter	Min.	Typ.	Max.	Units
Ambient Operating Temperature	-40		+85	°C
Power Supply Voltage (measured in respect to GND)	+1.6		+3.6	V



## DC Electrical Characteristics

VDD=1.8 V  $\pm$ 5%, Ambient temperature -40 to +85°C, unless stated otherwise

Parameter	Symbol	Conditions	Min.	Typ.	Max.	Units
Operating Voltage	VDD		1.71		1.89	V
Input High Voltage	V <sub>IH</sub>	Note 1, ICLK, OE	1.17		3.6	V
Input Low Voltage	V <sub>IL</sub>	Note 1, ICLK, OE			0.63	V
Output High Voltage	V <sub>OH</sub>	I <sub>OH</sub> = -6 mA	1.35			V
Output Low Voltage	V <sub>OL</sub>	I <sub>OL</sub> = 6 mA			0.45	V
Operating Supply Current	IDD	No load, 133 MHz		25		mA
Nominal Output Impedance	Z <sub>O</sub>			20		$\Omega$
Input Capacitance	C <sub>IN</sub>	ICLK, OE pin		5		pF
Short Circuit Current	I <sub>OS</sub>			$\pm$ 28		mA

Notes: 1. Nominal switching threshold is VDD/2

VDD=2.5 V  $\pm$ 5%, Ambient temperature -40 to +85°C, unless stated otherwise

Parameter	Symbol	Conditions	Min.	Typ.	Max.	Units
Operating Voltage	VDD		2.375		2.625	V
Input High Voltage, ICLK	V <sub>IH</sub>	Note 1, ICLK, OE	1.7		3.6	V
Input Low Voltage, ICLK	V <sub>IL</sub>	Note 1, ICLK, OE			0.7	V
Output High Voltage	V <sub>OH</sub>	I <sub>OH</sub> = -8 mA	2			V
Output Low Voltage	V <sub>OL</sub>	I <sub>OL</sub> = 8mA			0.4	V
Operating Supply Current	IDD	No load, 133 MHz		50		mA
Nominal Output Impedance	Z <sub>O</sub>			20		$\Omega$
Input Capacitance	C <sub>IN</sub>	ICLK, OE pin		5		pF
Short Circuit Current	I <sub>OS</sub>			$\pm$ 50		mA

Notes: 1. Nominal switching threshold is VDD/2



## AC Electrical Characteristics

VDD = 1.8 V  $\pm$ 5%, Ambient Temperature -40 to +85°C, unless stated otherwise

Parameter	Symbol	Conditions	Min.	Typ.	Max.	Units
Input Frequency			0		166	MHz
Output Rise Time	t <sub>OR</sub>	0.63 V to 1.17 V		1.0	1.5	ns
Output Fall Time	t <sub>OF</sub>	1.17 V to 0.63 V		1.0	1.5	ns
Propagation Delay	Note 1		2.2	3	5	ns
Output to Output Skew	Note 2	Rising edges at VDD/2		0	$\pm$ 250	ps

VDD = 2.5 V  $\pm$ 5%, Ambient Temperature -40 to +85°C, unless stated otherwise

Parameter	Symbol	Conditions	Min.	Typ.	Max.	Units
Input Frequency			0		200	MHz
Output Rise Time	t <sub>OR</sub>	0.7 V to 1.7 V		1.0	1.5	ns
Output Fall Time	t <sub>OF</sub>	1.7 V to 0.7 V		1.0	1.5	ns
Propagation Delay	Note 1		2.2	3	5	ns
Output to Output Skew	Note 2	Rising edges at VDD/2		0	$\pm$ 250	ps

- Notes: 1. With rail to rail input clock  
2. Between any 2 outputs with equal loading.

## Thermal Characteristics

Parameter	Symbol	Conditions	Min.	Typ.	Max.	Units
Thermal Resistance Junction to Ambient	$\theta_{JA}$	Still air		150		°C/W
	$\theta_{JA}$	1 m/s air flow		140		°C/W
	$\theta_{JA}$	3 m/s air flow		120		°C/W
Thermal Resistance Junction to Case	$\theta_{JC}$			40		°C/W



**Package Outline and Package Dimensions (8-pin SOIC, 150 Mil. Narrow Body)**

Package dimensions are kept current with JEDEC Publication No. 95

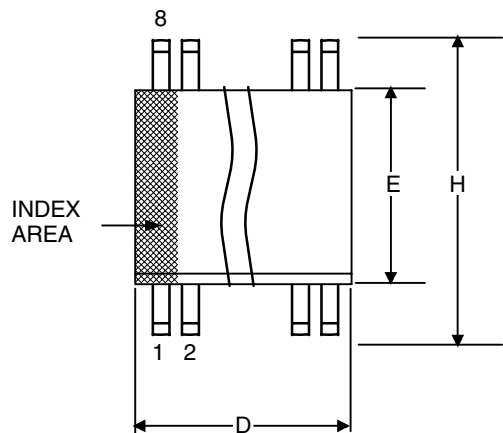

Symbol	Millimeters		Inches*	
	Min	Max	Min	Max
A	1.35	1.75	.0532	.0688
A1	0.10	0.25	.0040	.0098
B	0.33	0.51	.013	.020
C	0.19	0.25	.0075	.0098
D	4.80	5.00	.1890	.1968
E	3.80	4.00	.1497	.1574
e	1.27 BASIC		0.050 BASIC	
H	5.80	6.20	.2284	.2440
h	0.25	0.50	.010	.020
L	0.40	1.27	.016	.050
$\alpha$	0°	8°	0°	8°

\*For reference only. Controlling dimensions in mm.

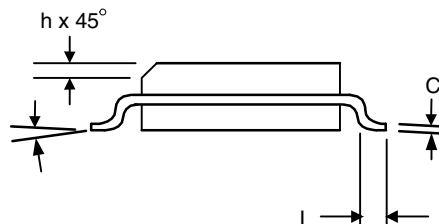
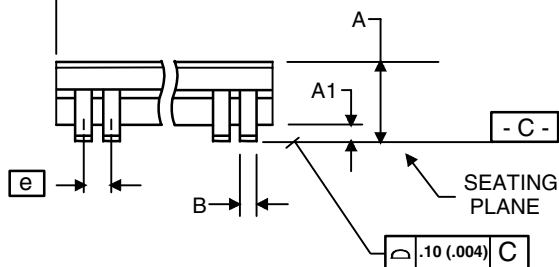

**Ordering Information**

Part / Order Number	Marking	Shipping Packaging	Package	Temperature
ICS651MI	ICS651MI	Tubes	8-pin SOIC	-40 to +85°C
ICS651MIT	ICS651MI	Tape and Reel	8-pin SOIC	-40 to +85°C
ICS651MILF	651MILF	Tubes	8-pin SOIC	-40 to +85°C
ICS651MILFT	651MILF	Tape and Reel	8-pin SOIC	-40 to +85°C

**Parts that are ordered with a "LF" suffix to the part number are the Pb-Free configuration and are RoHS compliant.**

While the information presented herein has been checked for both accuracy and reliability, Integrated Circuit Systems (ICS) result from its use. No other circuits, patents, or licenses are implied. This product is intended for use in normal commercial applications. Any other applications such as those requiring extended temperature range, high reliability, or other extraordinary environmental requirements are not recommended without additional processing by ICS. ICS reserves the right to change any circuitry or specifications without notice. ICS does not authorize or warrant any ICS product for use in life support devices or critical medical instruments.



**Revision History**

<b>Rev.</b>	<b>Originator</b>	<b>Date</b>	<b>Description of Change</b>
A	K. Beckmeyer	6/27/05	Preliminary Datasheet
B	K. Beckmeyer	8/31/05	Output high and low voltage current conditions changed to 6mA and 6mA respectively at 1.8V, and -8mA and 8mA respectively at 2.5V operation. Short circuit current spec changed to $\pm 50$ mA typical at 2.5V operation. Output-to-output skew max spec changed to $\pm 250$ ps at both 1.8V and 2.5V operation.
C	K. Beckmeyer	12/08/05	Added LF ordering info.