

CST-1010

Description:

Triad current sense transformers are used to detect the current passing through a conductor. These transformers are very reliable and operate efficiently at 50/60Hz.

Electrical Specifications (@25C)

IP Amps	Turns Ratio	Terminating Resistor		DCR (Ω) Nominal	Volts/Amp@ rated IP for various loads (Ω)				Net Weight Grams
		Ohms	Watts		100	500	2K	5K	
10	1000:1	100	.010	40	.0969	.4565	.9686	1.1912	20

Operating Temperature: -20C° to 85C°

Dimensions:

A	B	C	D	E	F
23.50	24.80	12.00	15.00	7.50	8.50

Units: In mm

Response curve: **Vout vs Input current (100 Ω load)**

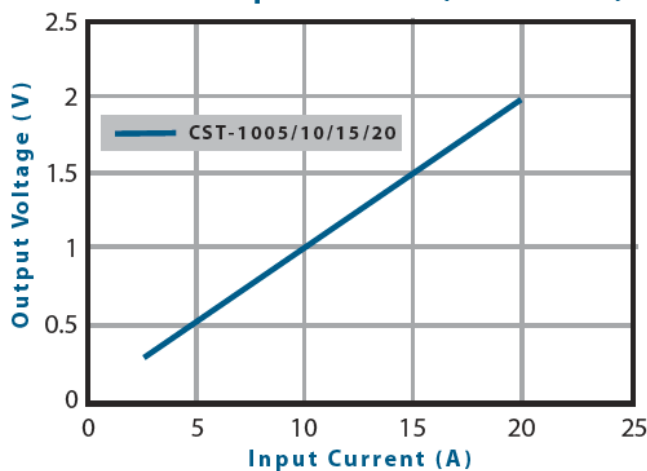

Technical Notes:

1. Pin3 for mechanical support only.
2. Pin diameter is 0.8±0.1 mm.
3. Pin length is 5±1mm.

Agency Files:

UL file E205349 – Component, Instrument Transformer (XODW2)



RoHS Compliance: As of manufacturing date February 2016, all standard products meet the requirements of 2015/863/EU, known as the RoHS 3 initiative.

*Upon printing, this document is considered "uncontrolled". Please contact Triad Magnetics website for the most current version. For soldering and washing information please see <http://www.triadmagnetics.com>

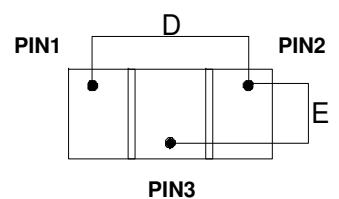
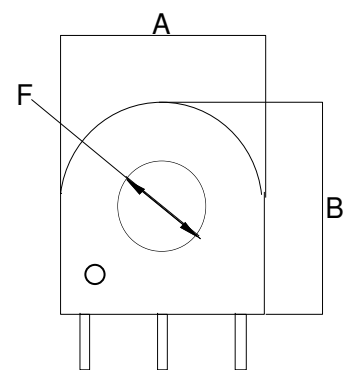
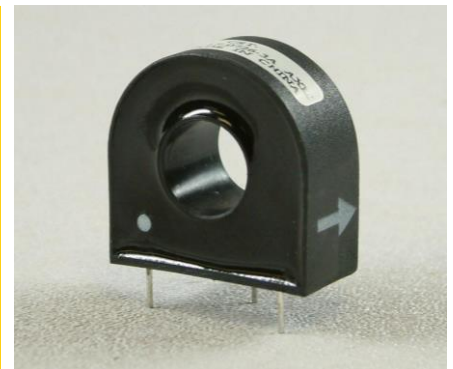

BOTTOM VIEW

