

THIS DRAWING IS UNPUBLISHED.
 VERTRAULICHE UNVERÖFFENTLICHTE ZEICHNUNG
 RELEASED FOR PUBLICATION
 FREI FUER VERÖFFENTLICHUNG
 .1997
 BY AMP INCORPORATED. ALL RIGHTS RESERVED.
 ALLE RECHTE VORBEHALTEN

MATED WITH: PASSEND ZU: SB	LOC A1	DIST -	REVISIONS ÄNDERUNGEN		
	P	LTR	DESCRIPTION BESCHREIBUNG	DATE	DWN AR
PROJEKT NR.: -	A1		Zeichnung erstellt	21.04.98	APVD AK

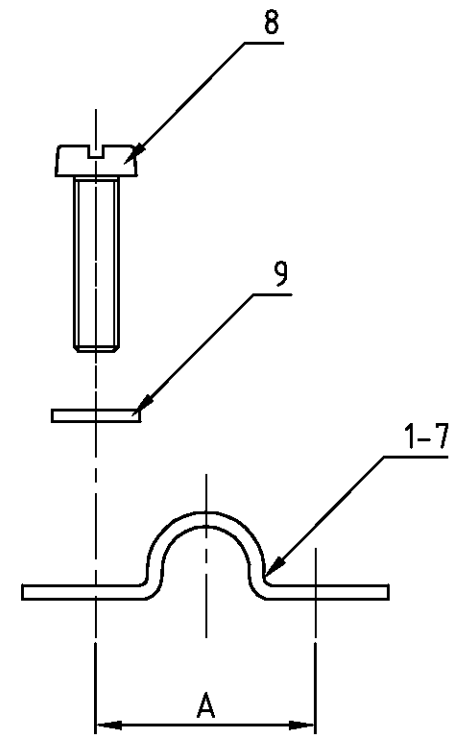

2	2	2	2	2	2	2		Federring A3	Steel/Stahl	verzinkt		9	
2	2	2	2	2	2	2		Schraube M3 x 12	Steel/Stahl	verzinkt		8	
1								Schelle 10 mm	Steel/Stahl	verzinkt	20	7	
	1							Schelle 9 mm	Steel/Stahl	verzinkt	20	6	
		1						Schelle 8 mm	Steel/Stahl	verzinkt	20	5	
			1					Schelle 7 mm	Steel/Stahl	verzinkt	20	4	
				1				Schelle 6 mm	Steel/Stahl	verzinkt	16	3	
					1			Schelle 5 mm	Steel/Stahl	verzinkt	15	2	
						1		Schelle 4,5 mm	Steel/Stahl	verzinkt	16	1	

AMP PART NO	DESCRIPTION	MATERIAL	SURFACE	DIM "A"	ITEM NO	NOTES
Schellenset 10 mm						<p>THIS DRAWING IS A CONTROLLED DOCUMENT FOR AMP INCORPORATED. IT IS SUBJECT TO CHANGE AND THE CONTROLLING ENGINEERING ORGANIZATION SHOULD BE CONTACTED FOR THE LATEST REVISION. DIESER ZEICHNUNGSDOKUMENT WIRD DURCH AMP INCORPORATED KONTROLLIERT. ÄNDERUNGEN, DIE DEM TECHNISCHEN FORTSCHRITT DIENEN, SIND VORBEHALTEN. DEN JEWELIG LETZTIGELTIGEN ÄNDERUNGSSTAND ERFAHREN SIE AUF ANFRAGE.</p> <p>AMP HTS Elektrotechnik 53819 Neunkirchen, Germany</p> <p>CABLE CLAMP SHELLENSET</p> <p>NAME: CABLE CLAMP SCHELLENSET</p> <p>SIZE: A3 CAGE CODE: 00779 DRAWING NO: C-1106302 RESTRICTED TO NUR FUER: -</p> <p>APPLICATION SPEC: VERARBEITUNGSSPEZ. WEIGHT: - CUSTOMER DRAWING: /KUNDENZEICHNUNG</p> <p>MASSSTAB: 1:1 BLATT: 1 OF VON: 1 REV: A1</p>
Schellenset 9 mm						
Schellenset 8 mm						
Schellenset 7 mm						
Schellenset 6 mm						
Schellenset 5 mm						
Schellenset 4,5 mm						

DIMENSIONS:
DIMENSIONEN:
mm

TOLERANCES UNLESS OTHERWISE SPECIFIED:
ALLGEMEINTOLERANZEN

ISO 8015
ISO 2768 - mH - E
DIN 16901 - 140

0 PLC
1 PLC
2 PLC
3 PLC

ANGLES / WINKEL
FINISH / OBERFLÄCHE / FARBE

MATERIAL