

NPN Silicon Phototransistors

Types OP641SL, OP642SL, OP643SL, OP644SL

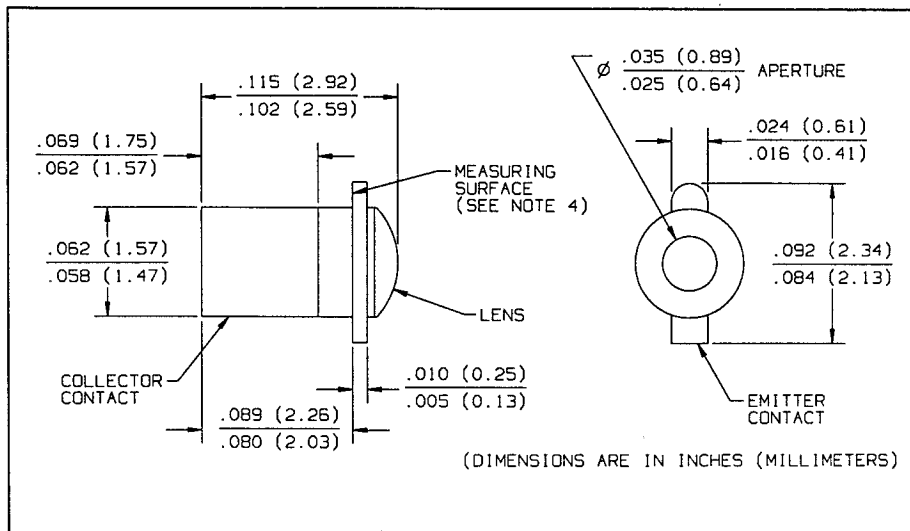
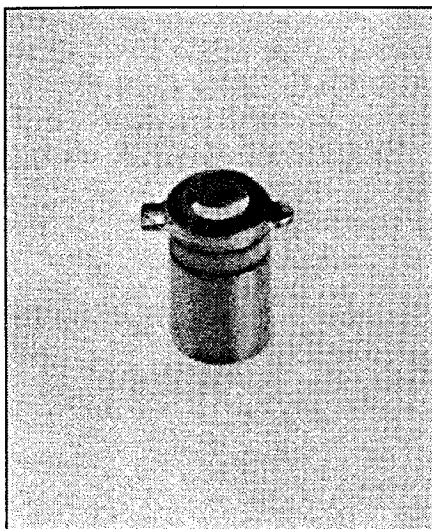

Features

- Narrow receiving angle
- Variety of sensitivity ranges
- Enhanced temperature range
- Ideal for direct mounting in PC boards
- Mechanically and spectrally matched to the OP123 and OP223 series LED's

Description

The OP641SL series devices consist of NPN silicon phototransistors mounted in hermetically sealed packages. The narrow receiving angle provides excellent on-axis coupling.

Replaces

OP600, OP640 series

Absolute Maximum Ratings ($T_A = 25^\circ\text{C}$ unless otherwise noted)

Collector-Emitter Voltage	25 V
Emitter-Collector Voltage	5.0 V
Storage Temperature Range	-65°C to $+150^\circ\text{C}$
Operating Temperature Range	-65°C to $+125^\circ\text{C}$
Soldering Temperature (5 sec. with soldering iron)	$260^\circ\text{C}^{(1)(2)}$
Power Dissipation	$50\text{ mW}^{(3)}$
Continuous Collector Current	50 mA

Notes:

- (1) Refer to Application Bulletin 202 which discusses proper techniques for soldering Pill type devices to PC boards.
- (2) No clean or low solids, RMA flux is recommended. Duration can be extended to 10 sec. max. when flow soldering.
- (3) Derate linearly $0.5\text{ mW}/^\circ\text{C}$ above 25°C .
- (4) Junction temperature maintained at 25°C .
- (5) Light source is an unfiltered tungsten bulb operating at $CT = 2870\text{ K}$ or equivalent infrared source.

Typical Performance Curves

Typical Spectral Response

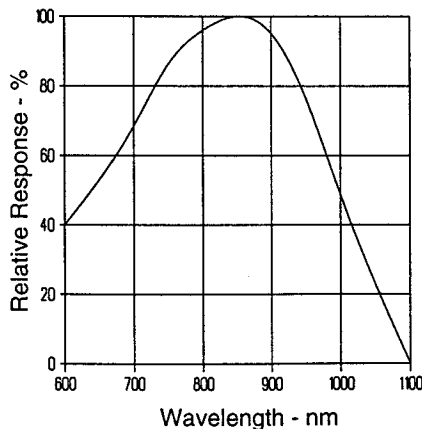

Coupling Characteristics of OP123 and OP641

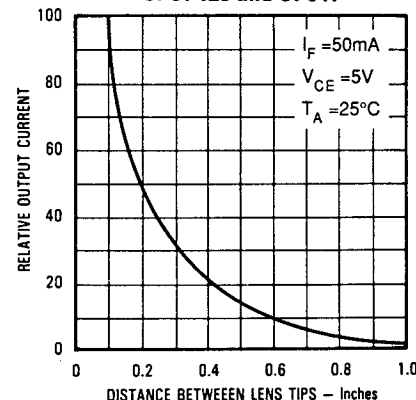

Types OP641SL, OP642SL, OP643SL, OP644SL

Electrical Characteristics ($T_A = 25^\circ\text{C}$ unless otherwise noted)

SYMBOL	PARAMETER	MIN	TYP	MAX	UNITS	TEST CONDITIONS
$I_{C(ON)}^{(4)}$	On-State Collector Current	OP641SL	0.5		3.0	$V_{CE} = 5\text{ V}, E_e = 20\text{ mW/cm}^2^{(5)}$
		OP642SL	2.0		5.0	
		OP643SL	4.0		8.0	
		OP644SL	7.0		22.0	
I_{CEO}	Collector Dark Current			100	nA	$V_{CE} = 10\text{ V}, E_e = 0$
$V_{(BR)CEO}$	Collector-Emitter Breakdown Voltage	25			V	$I_C = 100\text{ }\mu\text{A}$
$V_{(BR)ECO}$	Emitter-Collector Breakdown Voltage	5.0			V	$I_E = 100\text{ }\mu\text{A}$
$V_{CE(SAT)}^{(4)}$	Collector-Emitter Saturation Voltage			0.40	V	$I_C = 0.4\text{ mA}, E_e = 20\text{ mW/cm}^2^{(5)}$
t_r	Rise Time		15		μs	$V_{CC} = 5\text{ V}, I_C = 0.80\text{ mA}, R_L = 1\text{ k}\Omega$, See Test Circuit
t_f	Fall Time		15		μs	

PHOTOSENSORS

Typical Performance Curves

