

Model 5255 Die Cast Box, With Card Guides Size J, Unpainted

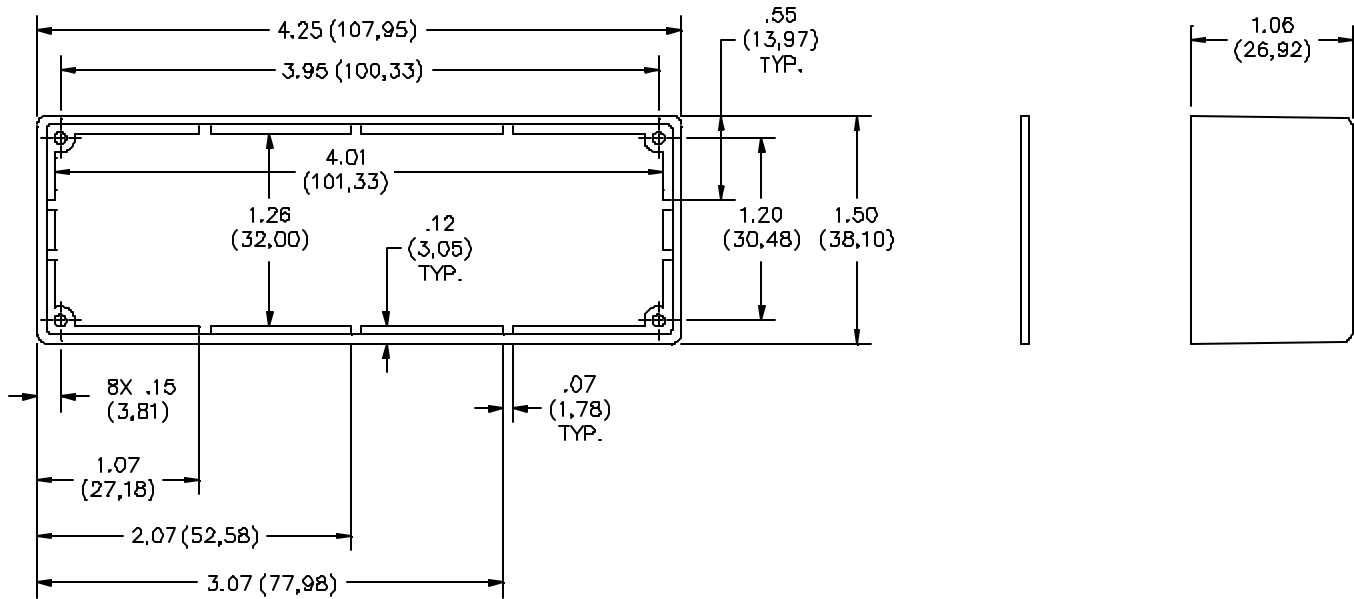

MATERIALS:

Die Cast Box:

- Aluminum, die cast, Alloy 380 or A384
- Finish: None
- Marking: "POMONA ELECTRONICS, CALIF"

Cover:

- 1.60 (.063) thick aluminum, Alloy 1100-H14
- Finish: Clear anodized
- Marking: None

Screws:

- 4 each 2-32 X 6.35 (.25) long, pan head, slotted, self-tapping Steel

RATINGS:

Operating Temperature: -55°C. to +150°C. (-67°F. to +302°F.)

ORDERING INFORMATION: Model 5255

All dimensions are in inches. Tolerances (except noted): .xx = ±.02" (.51 mm), .xxx = ±.005" (.127 mm).
All specifications are to the latest revisions. Specifications are subject to change without notice.
Registered trademarks are the property of their respective companies.

Made in USA