

THIS DRAWING IS UNPUBLISHED. RELEASED FOR PUBLICATION .19
 © COPYRIGHT 19 BY AMP INCORPORATED. ALL RIGHTS RESERVED.

LOC		DIST		REVISIONS			
P	LTR	DESCRIPTION		DATE	DWN	APVD	
	E	REV & REDRAWN; 0600-7141-98		1-99	CT	DE	
	F	REV PER 0600-8403-99		1-00	JEB	DE	

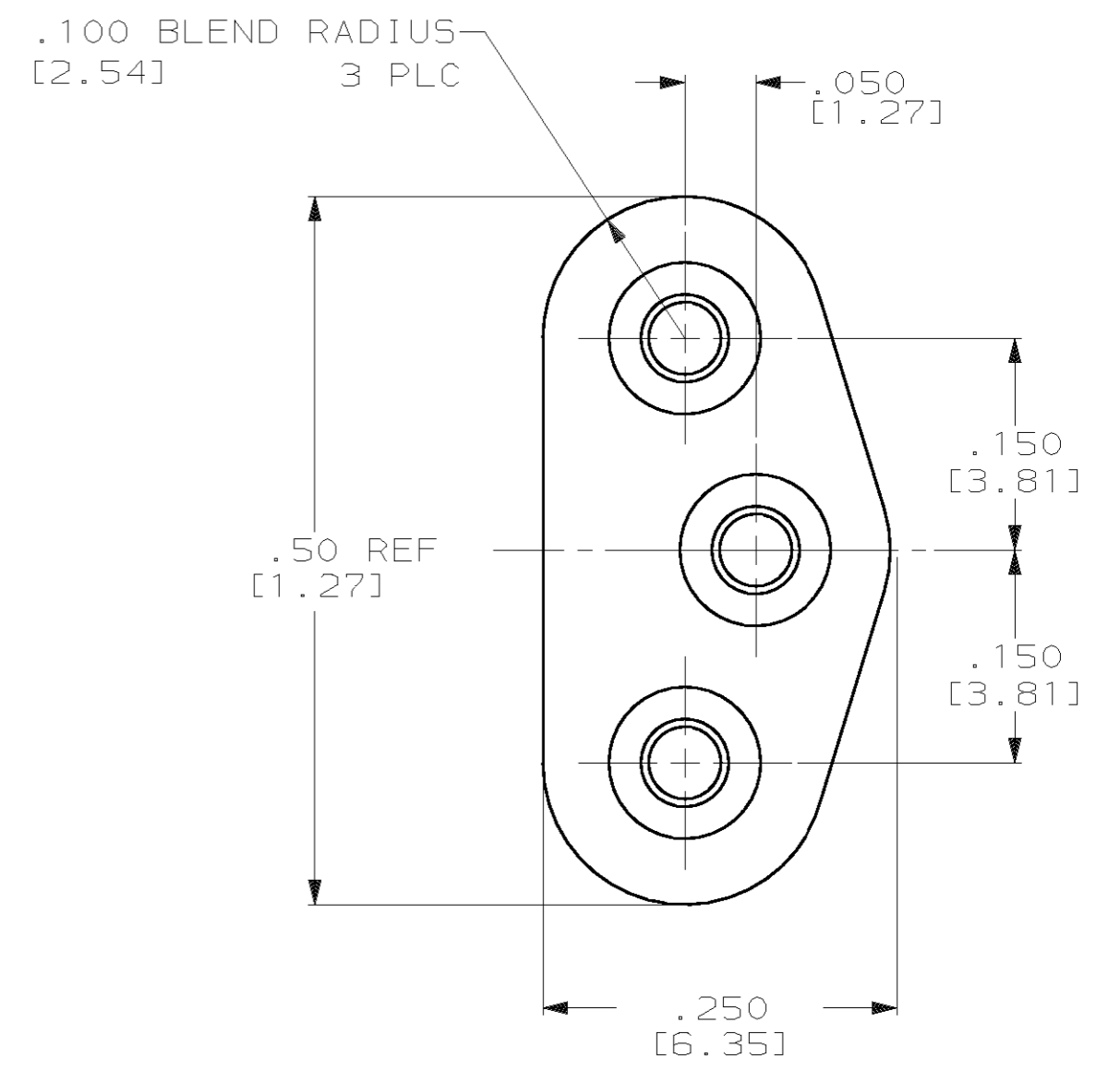
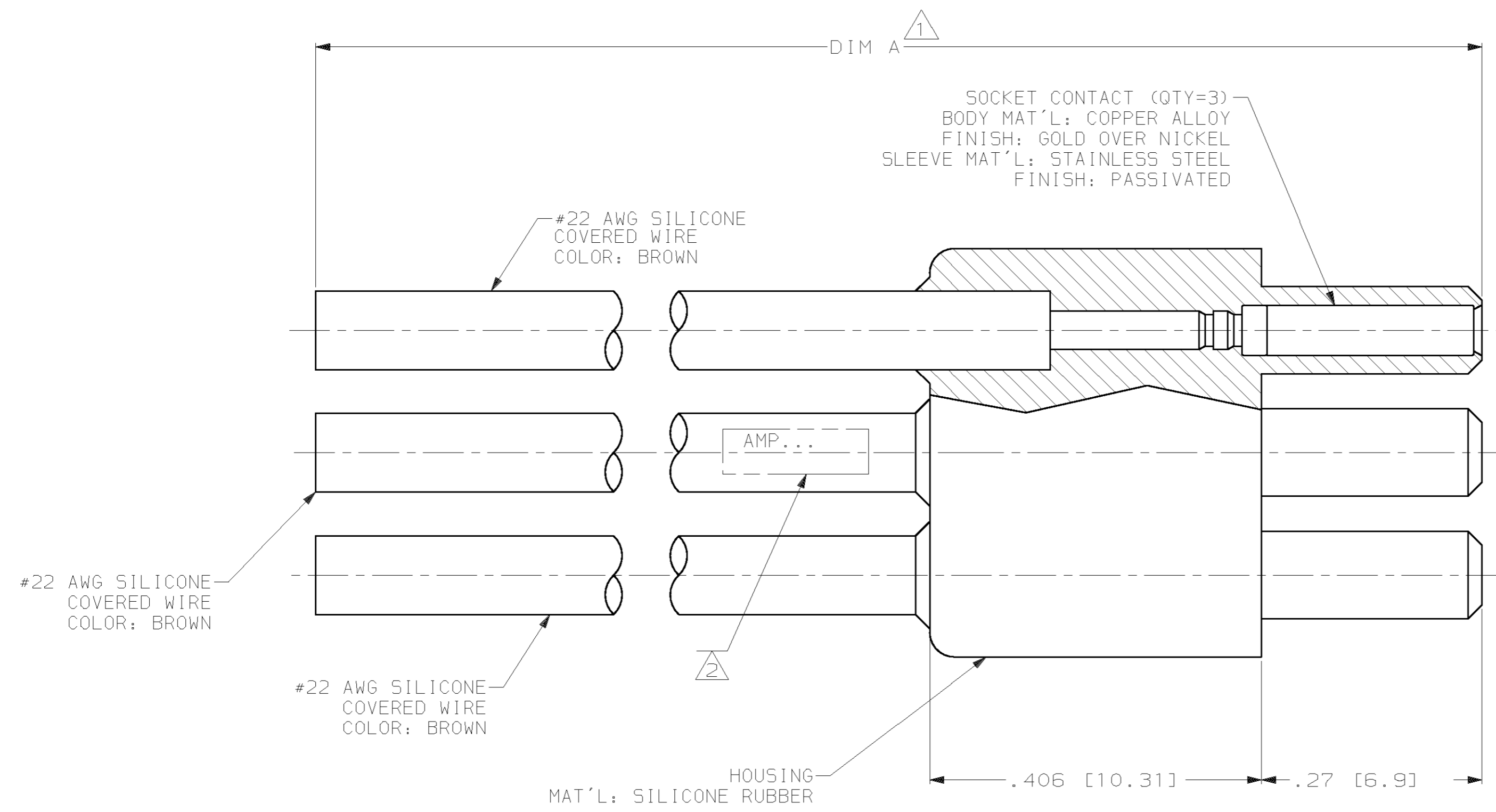

△1 TOLERANCE: UP TO 24.00 [609.6] ±.12 [3.0]
 24.00 [609.6] AND UP ±1%
 △2 AMP INFO MARKED PER MIL-STD-130.

OBSOLETE	48.00 [1219.2]	863743-5
OBSOLETE	18.00 [457.2]	863743-4
	24.00 [609.6]	863743-3
	16.00 [406.4]	863743-2
	12.00 [304.8]	863743-1
	A DIM	PART NO.

THIS DRAWING IS A CONTROLLED DOCUMENT.		DWN C.C. THOMAS 1/26/99	AMP Incorporated Harrisburg, PA 17105-3608													
DIMENSIONS: INCHES [mm]		CHK D.EABY 1/26/99	NAME D.EABY													
TOLERANCES UNLESS OTHERWISE SPECIFIED:		APVD D.EABY 1/26/99	PRODUCT SPEC													
<table border="1"> <tr><td>0 PLC</td><td>±-</td></tr> <tr><td>1 PLC</td><td>±-</td></tr> <tr><td>2 PLC</td><td>±.02 [0.5]</td></tr> <tr><td>3 PLC</td><td>±.005 [0.13]</td></tr> <tr><td>4 PLC</td><td>±-</td></tr> <tr><td>ANGLES</td><td>±-</td></tr> </table>		0 PLC	±-	1 PLC	±-	2 PLC	±.02 [0.5]	3 PLC	±.005 [0.13]	4 PLC	±-	ANGLES	±-	APPLICATION SPEC	PLUG, LGH, 3 POSN., MICRO-MIN	
0 PLC	±-															
1 PLC	±-															
2 PLC	±.02 [0.5]															
3 PLC	±.005 [0.13]															
4 PLC	±-															
ANGLES	±-															
MATERIAL	FINISH	WEIGHT	SIZE A2	CAGE CODE 00779												
			DRAWING NO C-863743	RESTRICTED TO												
CUSTOMER DRAWING			SCALE 8:1	SHEET 1 OF 1												
			REV F													