

mikroBoard for ARM 144-pin™

User manual

All MikroElektronika's development systems represent irreplaceable tools for programming and developing microcontroller-based devices. Carefully chosen components and the use of machines of the last generation for mounting and testing thereof are the best guarantee of high reliability of our devices. Due to simple design, a large number of add-on modules and ready to use examples, all our users, regardless of their experience, have the possibility to develop their project in a fast and efficient way.

Development system

 **MikroElektronika**

SOFTWARE AND HARDWARE SOLUTIONS FOR EMBEDDED WORLD ...making it simple

TO OUR VALUED CUSTOMERS

I want to express my thanks to you for being interested in our products and for having confidence in Mikroelektronika.

The primary aim of our company is to design and produce high quality electronic products and to constantly improve the performance thereof in order to better suit your needs.



Nebojsa Matic
General Manager

TABLE OF CONTENTS

| | |
|--|----|
| 1. General information | 4 |
| 2. LPC2214 microcontroller | 5 |
| 3. Programming the microcontroller | 8 |
| 4. Voltage regulator | 13 |
| 5. MicroSD connector | 14 |
| 6. Flash module | 15 |

1. General information

MikroBoard for ARM 144-pin is primarily intended to be connected to the EasyARM v6 development system but can also be used as a stand-alone device. The board features the LPC2214 microcontroller, flash module, USB connector, microSD connector, JTAG connector, USB UART, voltage regulator and connectors that enable connection with the development system.

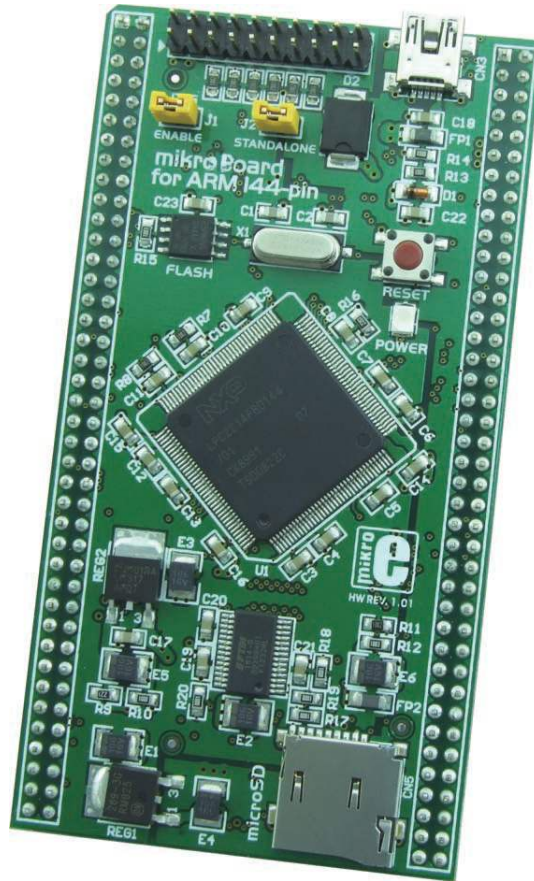

Figure 1-1: mikroBoard for ARM 144-pin

2. LPC2214 microcontroller

The LPC2214 microcontroller in 144-pin LQFP package is soldered on the mikoBoard for ARM 144-pin. Some of its key features are:

- 16/32-bit ARM7TDMI-S microcontroller in a LQFP144 package
- 16 kB on-chip static RAM and 256 kB on-chip flash program memory. 128-bit wide interface/accelerator enables high speed 60 MHz operation.
- In-System Programming (ISP) and In-Application Programming (IAP) via on-chip bootloader software.

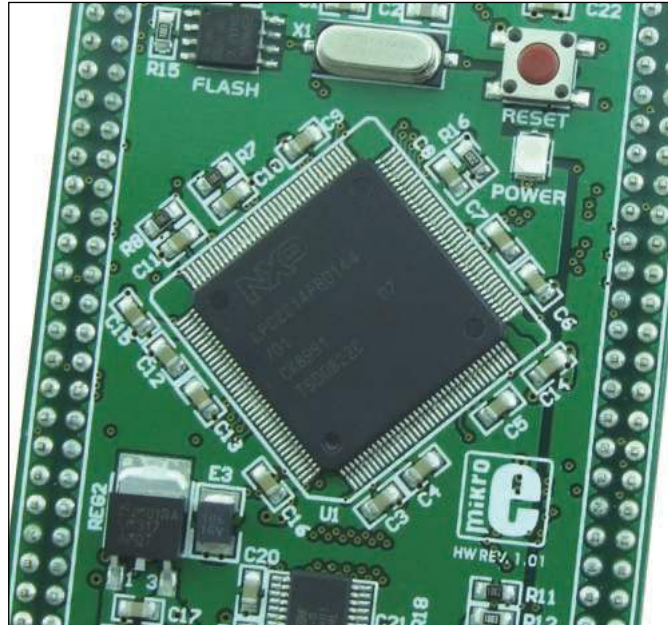

Figure 2-1: LPC2214 microcontroller

LPC2214 is connected to on board modules via pins which are also connected to CN1 and CN2 connectors. These two connectors enable the board to be connected to the EasyARM v6 development system or some other device.

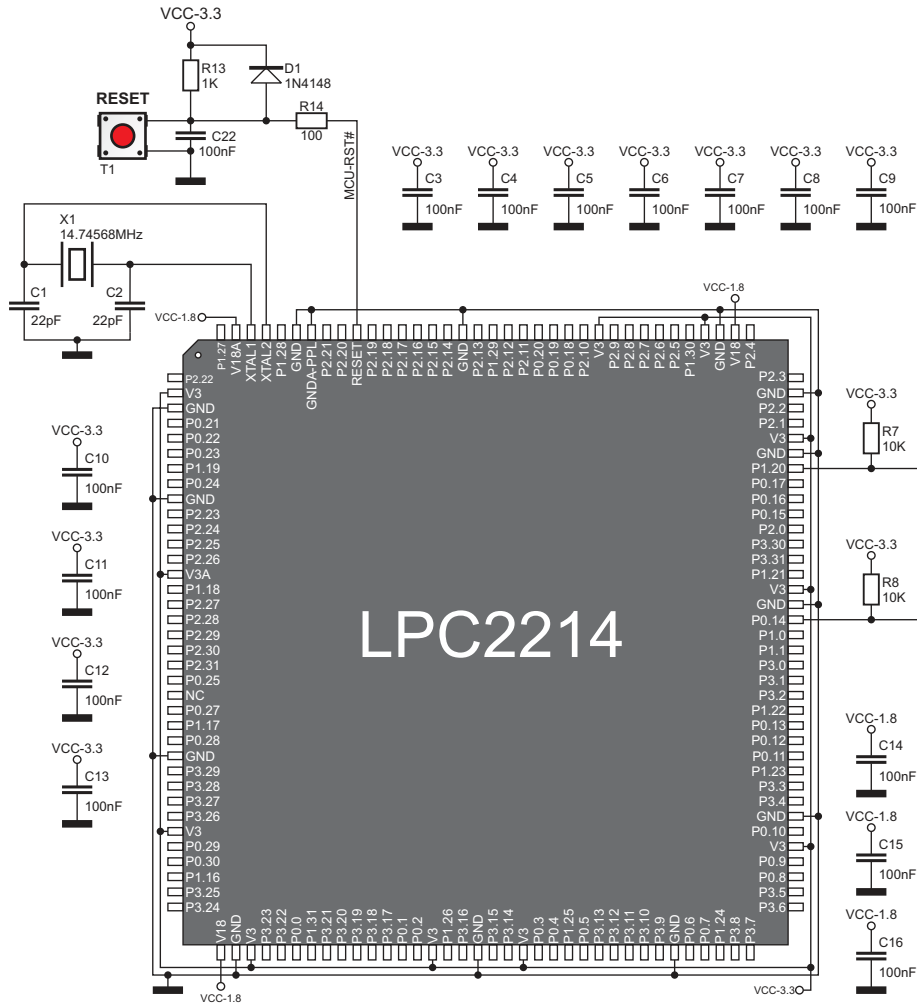

Figure 2-2: LPC2214 microcontroller with oscillators connection schematic

The LPC2214 microcontroller is connected to the X1 oscillator. The X1 oscillator generates a clock used for the operation of the microcontroller. The microcontroller can be cleared by feeding the reset pin with a logic 0, i.e. by pressing the RESET button.

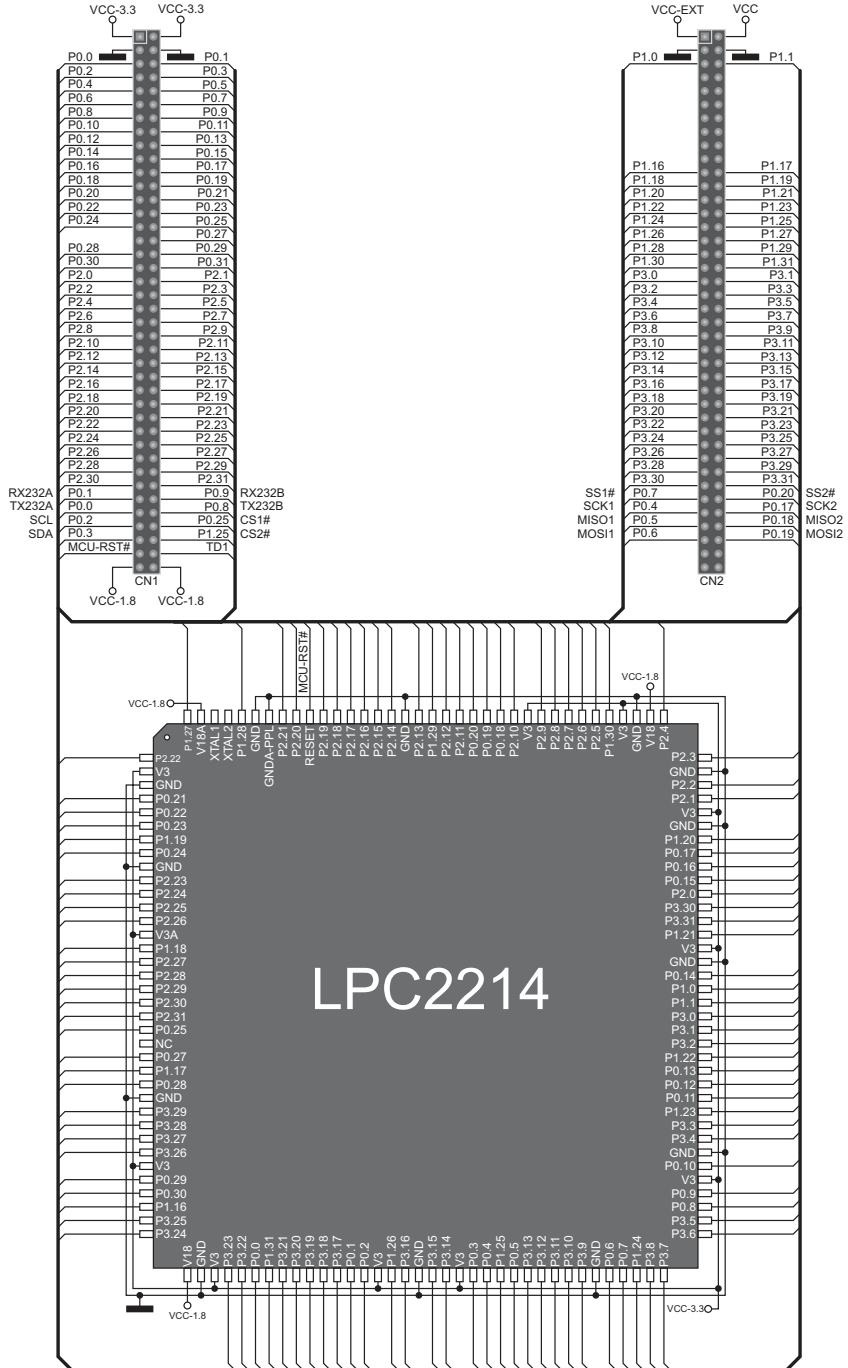

Figure 2-3: LPC2214 microcontroller with connectors connection schematic

3. Programming the microcontroller

The microcontroller can be programmed with a bootloader or the JTAG programmer. The use of bootloader is enabled due to the bootloader code that is loaded into the microcontroller. In order to program the microcontroller with the bootloader, it is necessary to connect the board to a PC via the CN3 connector and USB cable, Figure 3-1. A .hex code is transferred from the PC to the microcontroller by using some of the bootloader programs, such as Flash Magic.

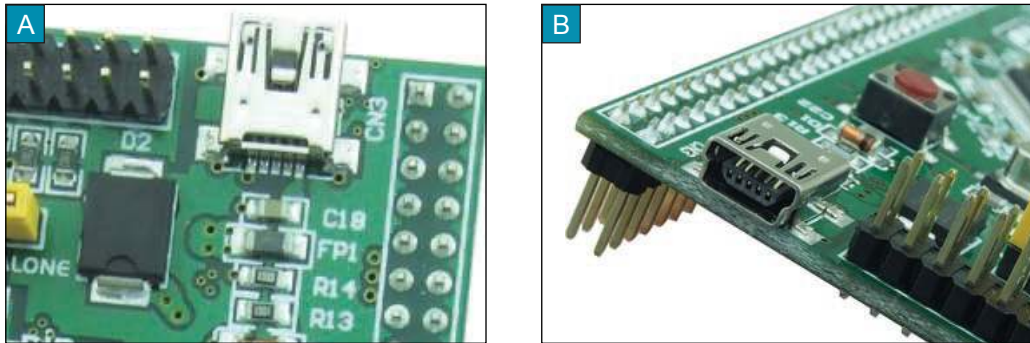

Figure 3-1: USB connector for programming

The CN3 USB connector is connected to the UART module built into the microcontroller via FTDI module (FT232RL).

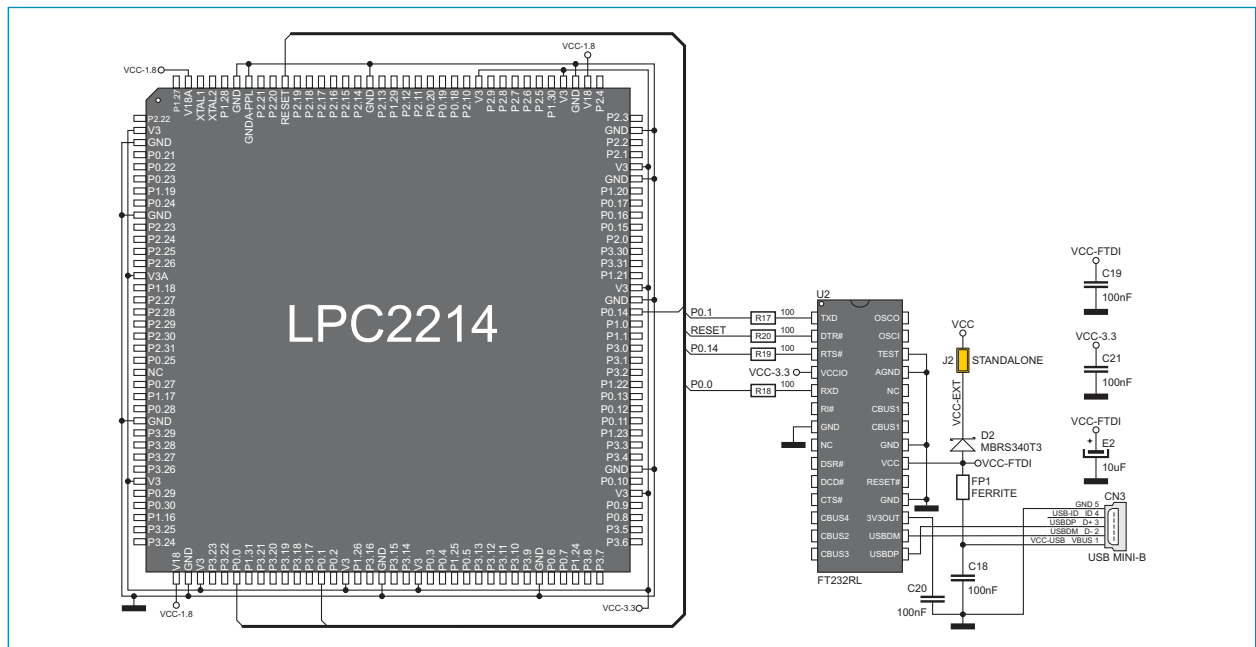
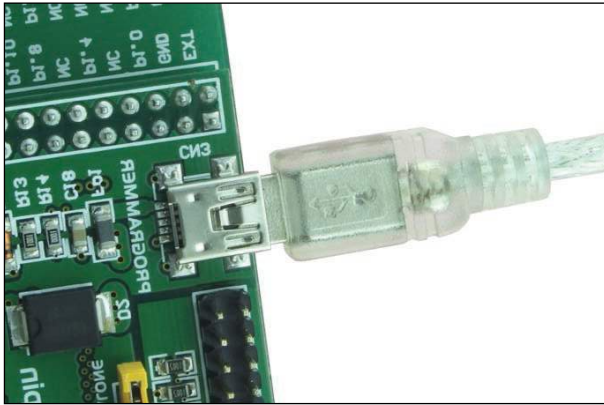

Figure 3-2: USB UART module connection schematic

When the mikroBoard for ARM 144-pin operates as a stand-alone device, it is necessary to place jumper J2 on the board. If the board is connected to the EasyARM v6 development system, jumper J2 should be removed.

In next few steps is explained how to program microcontroller with bootloader via Flash Magic application.

STEP 1: Connect the system to a PC



Connect the mikroBoard for ARM 144-pin to available USB port on your PC.

STEP 2: Start Flash Magic

Download the Flash Magic application from <http://www.flashmagictool.com/download.html&d=FlashMagic.exe> and install it on your PC

When the installation is finished double click on the Flash Magic icon



STEP 3: Select MCU

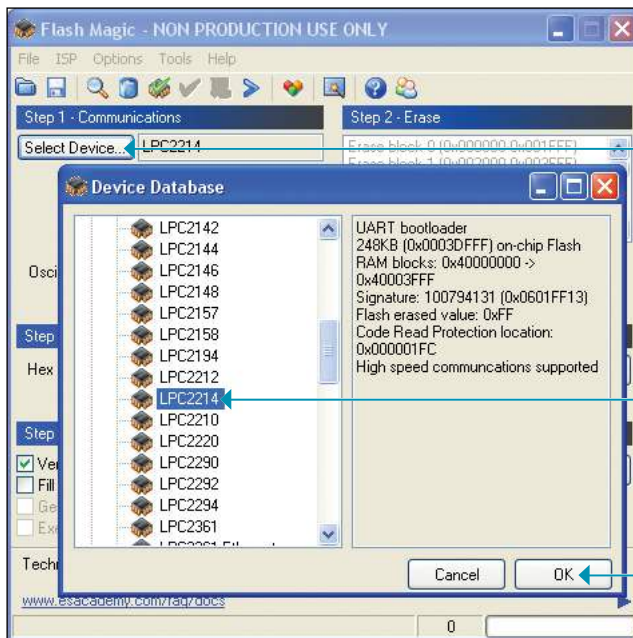

Click on the Select Device button

Select MCU from the list

Click OK

STEP 4: Settings

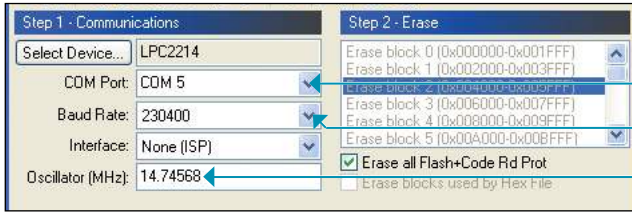

From drop-down menu select the COM port on your PC

Set Baud Rate to 230400

Enter 14.74568 (if you use different oscillator set the appropriate value in MHz)

Device Manager on your PC contains information on which COM port is used for USB communication with the mikroBoard for ARM 144-pin development system. In this case the COM5 port is used.



Right click on USB port, then on Properties

From pop-up window select the Port Settings tab

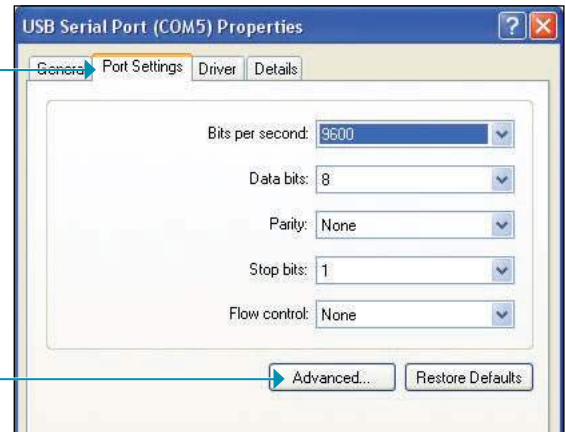

Click on the Advanced... button

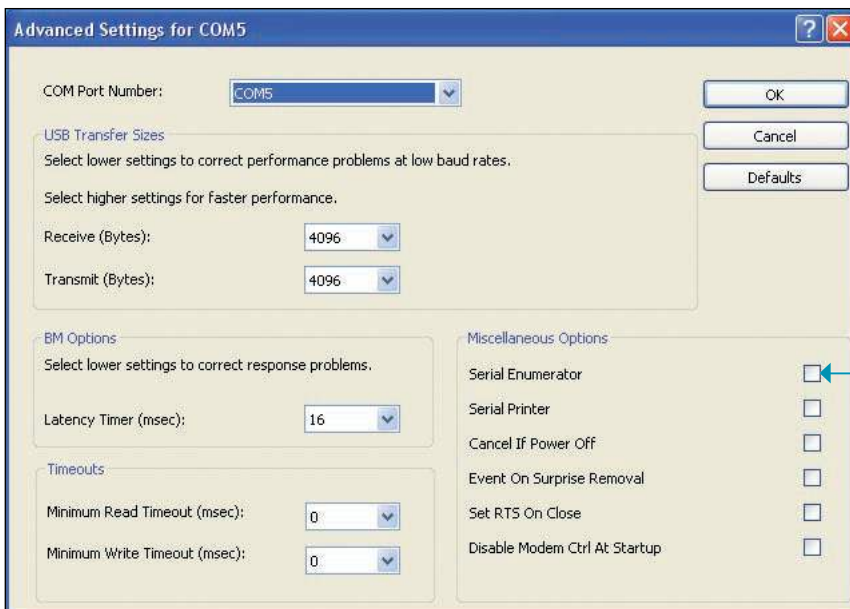

In pop-up window uncheck the Serial Enumeration option and click OK

STEP 5: Browse for .hex file

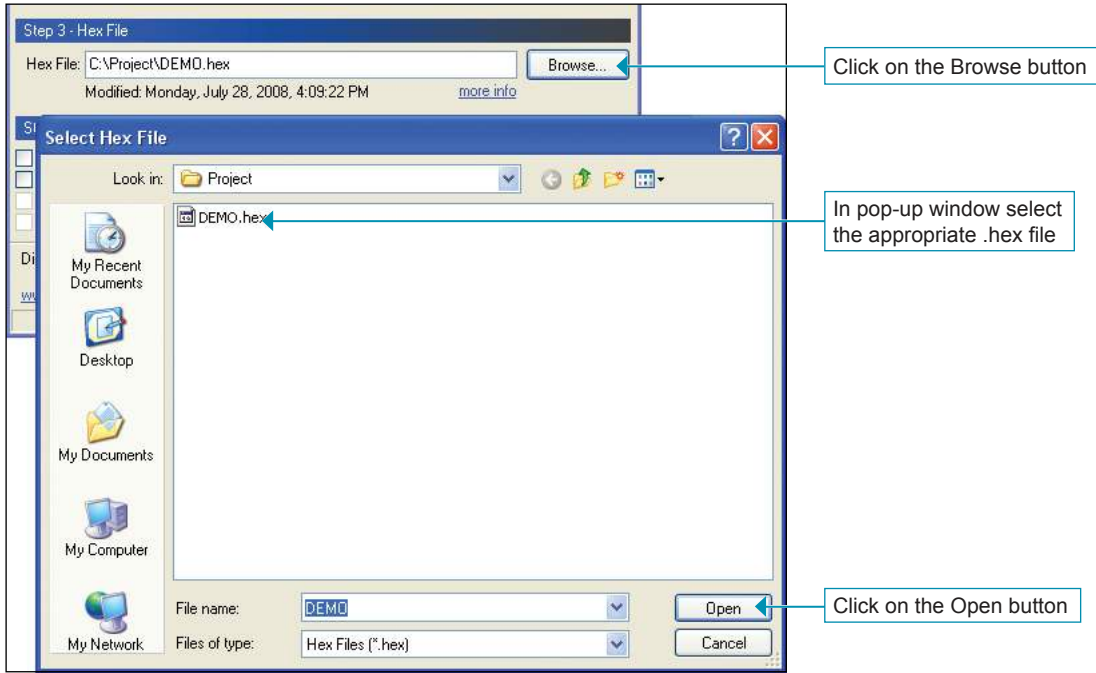

STEP 6: Upload .hex file

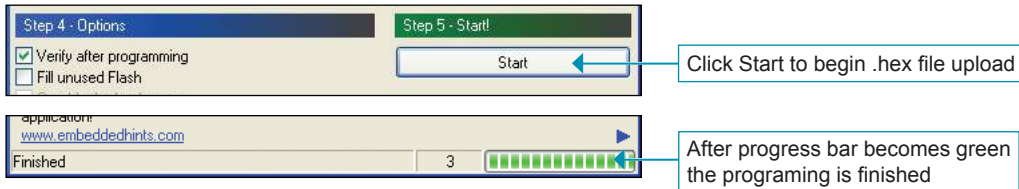

4. Voltage regulator

The microcontroller require dual power supply: 1.8V for CPU and 3.3V for I/O. The board is powered with the 5V power supply voltage via the CN3 USB connector supplied on the board.

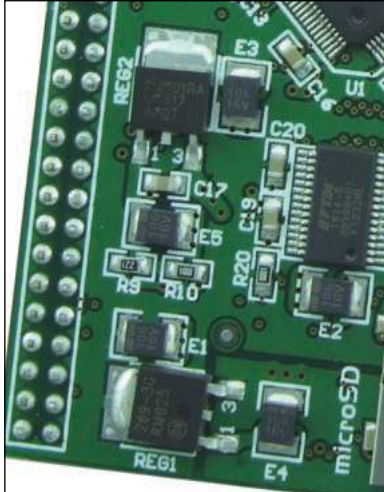

Figure 4-1: Voltage regulator

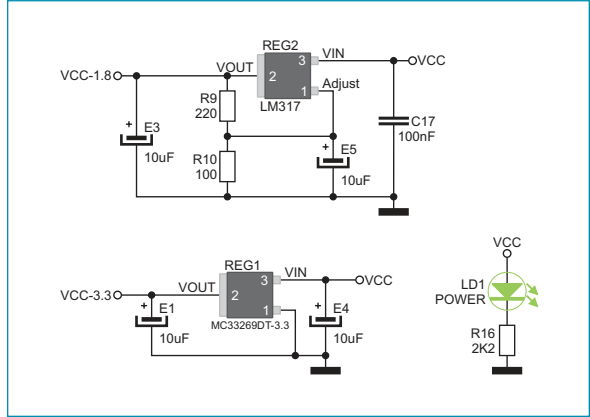

Figure 4-2: Voltage regulator connection schematic

If the board is powered by the development system (EasyARM v6), the function of the voltage regulator remains the same. In this case, it is necessary to remove jumper J2 (STANDALONE), Figure 4-3.



Figure 4-3: Standalone mode disabled



Figure 4-4: Standalone mode enabled

6. Flash module

Flash module provides additional 8Mbit of flash memory that the microcontroller can use via the Serial Peripheral Interface (SPI).



Figure 6-1: Flash memory

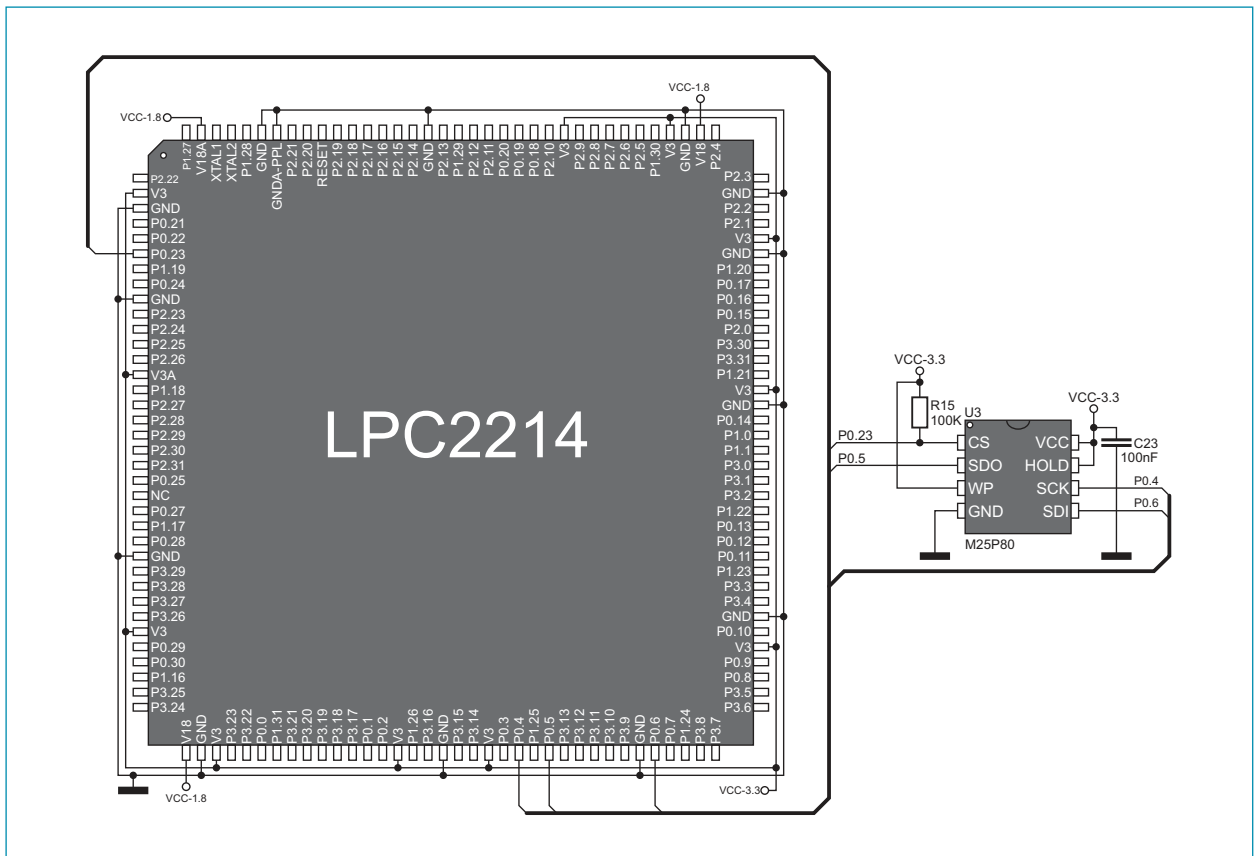

Figure 6-2: Flash module connection schematic

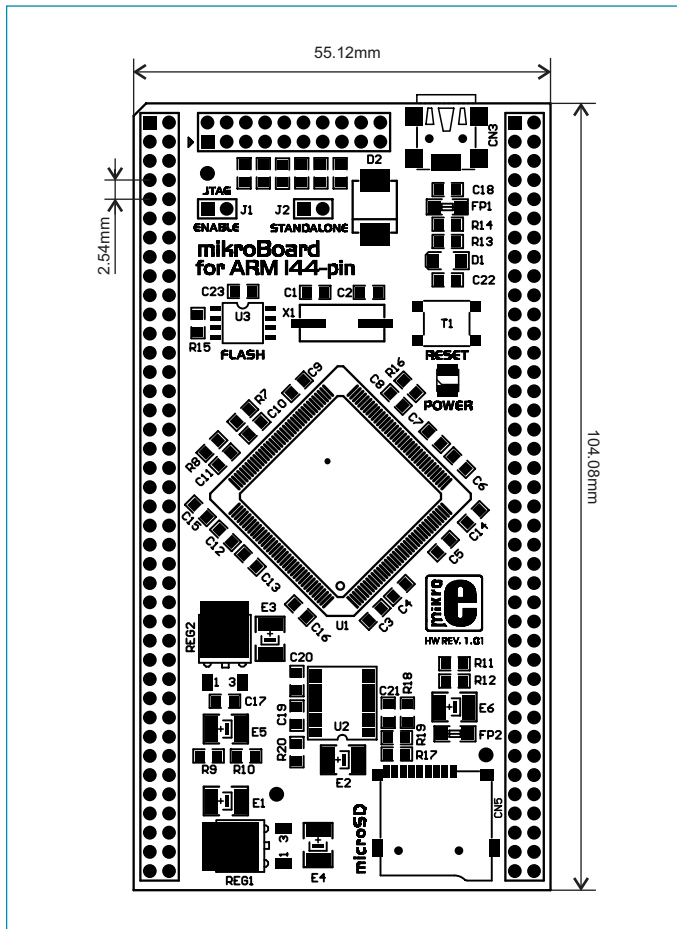

Figure 6-3: Dimensions of the mikroBoard for ARM 144-pin

DISCLAIMER

All the products owned by MikroElektronika are protected by copyright law and international copyright treaty. Therefore, this manual is to be treated as any other copyright material. No part of this manual, including product and software described herein, may be reproduced, stored in a retrieval system, translated or transmitted in any form or by any means, without the prior written permission of MikroElektronika. The manual PDF edition can be printed for private or local use, but not for distribution. Any modification of this manual is prohibited.

MikroElektronika provides this manual 'as is' without warranty of any kind, either expressed or implied, including, but not limited to, the implied warranties or conditions of merchantability or fitness for a particular purpose.

MikroElektronika shall assume no responsibility or liability for any errors, omissions and inaccuracies that may appear in this manual. In no event shall MikroElektronika, its directors, officers, employees or distributors be liable for any indirect, specific, incidental or consequential damages (including damages for loss of business profits and business information, business interruption or any other pecuniary loss) arising out of the use of this manual or product, even if MikroElektronika has been advised of the possibility of such damages. MikroElektronika reserves the right to change information contained in this manual at any time without prior notice, if necessary.

HIGH RISK ACTIVITIES

The products of MikroElektronika are not fault – tolerant nor designed, manufactured or intended for use or resale as on – line control equipment in hazardous environments requiring fail – safe performance, such as in the operation of nuclear facilities, aircraft navigation or communication systems, air traffic control, direct life support machines or weapons systems in which the failure of Software could lead directly to death, personal injury or severe physical or environmental damage ('High Risk Activities'). MikroElektronika and its suppliers specifically disclaim any expressed or implied warranty of fitness for High Risk Activities.

TRADEMARKS

The Mikroelektronika name and logo, the Mikroelektronika logo, mikroC, mikroC PRO, mikroBasic, mikroBasic PRO, mikroPascal, mikroPascal PRO, AVRflash, PICflash, dsPICprog, 18FJprog, PSOCprog, AVR-prog, 8051prog, ARMflash, EasyPIC5, EasyPIC6, BigPIC5, BigPIC6, dsPIC PRO4, Easy8051B, EasyARM, EasyAVR5, EasyAVR6, BigAVR2, EasydsPIC4A, EasyPSoC4, EasyVR Stamp LV18FJ, LV24-33A, LV32MX, PIC32MX4 MultiMedia Board, PICPLC16, PICPLC8 PICPLC4, SmartGSM/GPRS, UNI-DS are trademarks of Mikroelektronika. All other trademarks mentioned herein are property of their respective companies.

All other product and corporate names appearing in this manual may or may not be registered trademarks or copyrights of their respective companies, and are only used for identification or explanation and to the owners' benefit, with no intent to infringe.



MikroElektronika
SOFTWARE AND HARDWARE SOLUTIONS FOR EMBEDDED WORLD ...making it simple

If you want to learn more about our products, please visit our website at www.mikroe.com

If you are experiencing some problems with any of our products or just need additional information, please place your ticket at www.mikroe.com/en/support

If you have any questions, comments or business proposals, do not hesitate to contact us at office@mikroe.com