

MAX707, MAX708

μP Supervisory Circuits

The MAX707/708 are cost-effective system supervisor circuits designed to monitor V_{CC} in digital systems and provide a reset signal to the host processor when necessary. No external components are required.

The reset output is driven active within 20 μsec of V_{CC} falling through the reset voltage threshold. Reset is maintained with 200 mS of delay time after V_{CC} rise above the reset threshold. The MAX707/708 have a low quiescent current of 12 μA at $V_{CC} = 3.3$ V, an active-high RESET and active-low $\overline{\text{RESET}}$ with a push-pull output. The output is guaranteed valid down to $V_{CC} = 1.0$ V. The MAX707/708 have a Manual Reset $\overline{\text{MR}}$ input and a +1.25 V threshold detector for power-fail input PFI. These devices are available in a Micro8 and SOIC-8 package.

Features

- Precision Supply-Voltage Monitor
MAX707: 4.63 V Reset Threshold Voltage
MAX708: Standard Reset Threshold Voltages (Typical):
4.38 V, 3.08 V, 2.93 V, 2.63 V
- Reset Threshold Available from 1.6 V to 4.9 V with 100 mV Increments (Factory Option)
- 200 mS (Typ) Reset Timeout Delay
- 12 μA ($V_{CC} = 3.3$ V) Quiescent Current
- Active_High and Active_Low Reset Output
- Guaranteed RESET_L and RESET Output Valid to $V_{CC} = 1.0$ V
- Voltage Monitor for Power-Fail or Low-Battery Warning
- 8 Pin SOIC or Micro8 Package
- Pb-Free Packages are Available

Applications

- Computers
- Embedded System
- Battery Powered Equipment
- Critical μP Power Supply Monitor



ON Semiconductor®

<http://onsemi.com>

MARKING DIAGRAMS

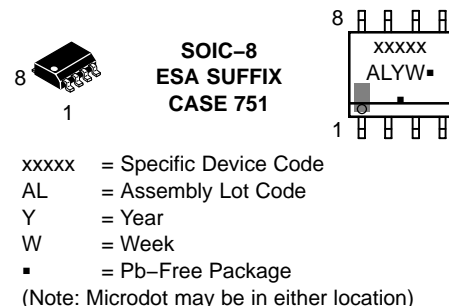
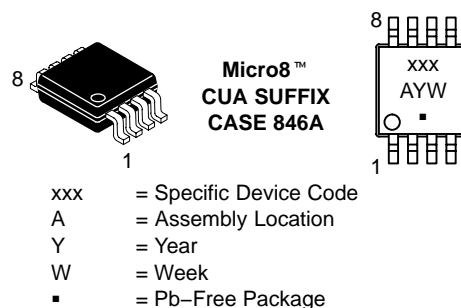

PIN CONFIGURATION

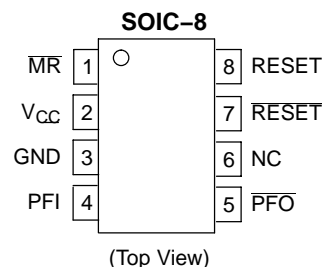
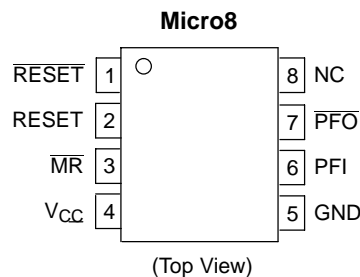

ORDERING INFORMATION

See detailed ordering and shipping information in the package dimensions section on page 8 of this data sheet.

MAX707, MAX708

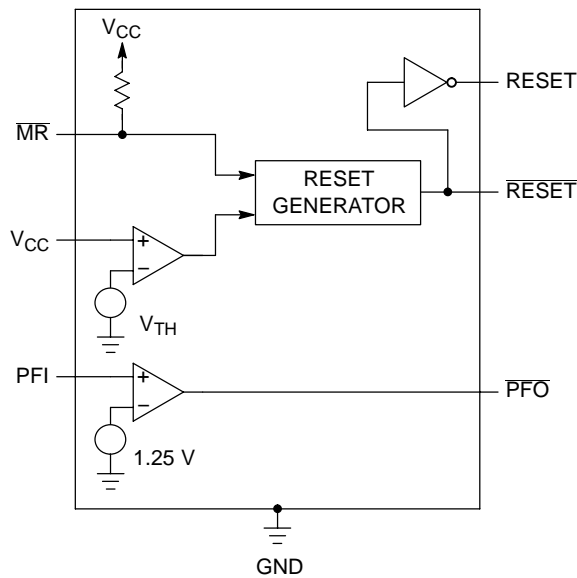

Figure 1. Representative Block Diagram

MAXIMUM RATINGS (Note 1)

Rating	Symbol	Value	Unit
Supply Voltage	V_{CC}	6.0	V
Output Voltage	V_{out}	-0.3 to $(V_{CC} + 0.3)$	V
Output Current (All Outputs)	I_{out}	20	mA
Input Current (V_{CC} and GND)	I_{in}	20	mA
Thermal Resistance Junction-to-Air	$R_{\theta JA}$	248 187	$^{\circ}C/W$
		Micro8 SOIC-8	
Operating Ambient Temperature	T_A	-40 to +85	$^{\circ}C$
Storage Temperature Range	T_{stg}	-40 to +125	$^{\circ}C$
LatchUp Performance	$I_{LATCHUP}$	300 280	mA
		Positive Negative	

Maximum ratings are those values beyond which device damage can occur. Maximum ratings applied to the device are individual stress limit values (not normal operating conditions) and are not valid simultaneously. If these limits are exceeded, device functional operation is not implied, damage may occur and reliability may be affected.

- This device series contains ESD protection and exceeds the following tests:
Human Body Model 2000 V per MIL-STD-883, Method 3015.
Machine Model Method 200 V.
- The maximum package power dissipation limit must not be exceeded.

$$P_D = \frac{T_{J(max)} - T_A}{R_{\theta JA}} \quad \text{with } T_{J(max)} = 150^{\circ}C$$

MAX707, MAX708

ELECTRICAL CHARACTERISTICS ($V_{CC} = 1.0 \text{ V to } 5.5 \text{ V}$, $T_A = -40^\circ\text{C to } +85^\circ\text{C}$, unless otherwise noted. Typical values are at $T_A = 25^\circ\text{C}$, $V_{CC} = 3.3 \text{ V}$.)

Characteristics	Symbol	Min	Typ	Max	Unit
Operating Voltage Range	V_{CC}	1.0	–	5.5	V
Supply Current $V_{CC} = 3.3 \text{ V}$ $V_{CC} = 5.5 \text{ V}$	I_{CC}	– –	12 16	22 28	μA
Reset Threshold MAX707 $T_A = +25^\circ\text{C}$ $T_A = -40^\circ\text{C to } +85^\circ\text{C}$ MAX708 $T_A = +25^\circ\text{C}$ $T_A = -40^\circ\text{C to } +85^\circ\text{C}$ MAX708T $T_A = +25^\circ\text{C}$ $T_A = -40^\circ\text{C to } +85^\circ\text{C}$ MAX708S $T_A = +25^\circ\text{C}$ $T_A = -40^\circ\text{C to } +85^\circ\text{C}$ MAX708R $T_A = +25^\circ\text{C}$ $T_A = -40^\circ\text{C to } +85^\circ\text{C}$	V_{TH}	4.56 4.50 4.31 4.25 3.03 3.00 2.89 2.85 2.59 2.55	4.63 – 4.38 – 3.08 – 2.93 – 2.63	4.70 4.75 4.45 4.50 3.13 3.15 2.97 3.00 2.67 2.70	V
Reset Threshold Hysteresis	V_{HYS}	–	$0.01 V_{TH}$	–	mV
V_{CC} Falling Reset Delay ($V_{CC} = V_{TH} + 0.2 \text{ V to } V_{TH} - 0.2 \text{ V}$)	t_{PD}	–	20	–	μS
Reset Active Timeout Period	t_{RP}	140	200	330	mS
RESET_L, RESET_H Output Low Voltage $V_{CC} \geq 1.0 \text{ V}$, $I_{ol} = 100 \mu\text{A}$ $V_{CC} > 2.7 \text{ V}$, $I_{ol} = 1.2 \text{ mA}$ $V_{CC} > 4.5 \text{ V}$, $I_{ol} = 3.2 \text{ mA}$	V_{ol}	– – –	– – –	0.3 0.3 0.3	V
RESET_L, RESET_H Output High Voltage $V_{CC} \geq 1.0 \text{ V}$, $I_{oh} = 50 \mu\text{A}$ $V_{CC} > 2.7 \text{ V}$, $I_{oh} = 500 \mu\text{A}$ $V_{CC} > 4.5 \text{ V}$, $I_{oh} = 800 \mu\text{A}$	V_{oh}	$0.8 V_{CC}$ $0.8 V_{CC}$ $0.8 V_{CC}$	– – –	– – –	V
MR_L Pull-up Resistance	R_{MRI}	50	–	–	$\text{K}\Omega$
MR_L Pulse Width ($V_{TH}(\text{max}) < V_{CC} < 5.5 \text{ V}$)	t_{MR}	1.0	–	–	μS
MR_L Glitch Rejection ($V_{TH}(\text{max}) < V_{CC} < 5.5 \text{ V}$)	–	–	0.1	–	μS
MR_L High_level Input Threshold ($V_{TH}(\text{max}) < V_{CC} < 5.5 \text{ V}$)	V_{IH}	$0.7 V_{CC}$	–	–	V
MR_L Low_level Input Threshold ($V_{TH}(\text{max}) < V_{CC} < 5.5 \text{ V}$)	V_{IL}	–	–	$0.3 V_{CC}$	V
MR_L to RESET_L and RESET_H Output Delay ($V_{TH}(\text{max}) < V_{CC} < 5.5 \text{ V}$)	t_{MD}	–	0.2	–	μS
PFI Input Threshold ($V_{CC} = 3.3 \text{ V}$, PFI Falling)	–	1.20	1.25	1.3	V
PFI Input Current	–	–250	0.01	250	nA
PFI to PFO Delay ($V_{CC} = 3.3 \text{ V}$, $V_{OVERDRIVE} = 15 \text{ mV}$)	–	–	3.0	–	μS
PFO_L Output Low Voltage $V_{CC} = 2.7 \text{ V}$, $I_{ol} = 1.2 \text{ mA}$ $V_{CC} = 4.5 \text{ V}$, $I_{ol} = 3.2 \text{ mA}$	V_{ol}	– –	– –	0.3 0.3	V
PFO_L Output High Voltage $V_{CC} = 2.7 \text{ V}$, $I_{oh} = 500 \mu\text{A}$ $V_{CC} = 4.5 \text{ V}$, $I_{oh} = 800 \mu\text{A}$	V_{oh}	$0.8 V_{CC}$ $0.8 V_{CC}$	– –	– –	V

MAX707, MAX708

PIN DESCRIPTION (Pin No. with parentheses is for Micro8 package.)

Pin No.	Symbol	Description
1 (3)	\overline{MR}	Manual Reset Input. \overline{MR} can be driven from TTL/CMOS logic or from a manual Reset switch. This input, when floating, is internally pulled up to V_{CC} with 50 k Ω resistor.
2 (4)	V_{CC}	Supply Voltage: C = 100 nF is recommended as a bypass capacitor between V_{CC} and GND.
3 (5)	GND	Ground Reference
4 (6)	PFI	Power Fail Voltage Monitor Input. When PFI is less than 1.25 V, \overline{PFO} goes low. Connect PFI to GND or V_{CC} when not used.
5 (7)	\overline{PFO}	Power Fail Monitor Output. When PFI is less than 1.25 V, it goes low and sinks current. Otherwise, it remains high.
6 (8)	NC	Non-connective Pin
7 (1)	\overline{RESET}	Active Low \overline{RESET} can be triggered by V_{CC} below the threshold level or by a low signal on \overline{MR} . It remains low for 200 ms (typ.) after V_{CC} rises above the reset threshold.
8 (2)	RESET	Active high RESET output the inverse of \overline{RESET} one.

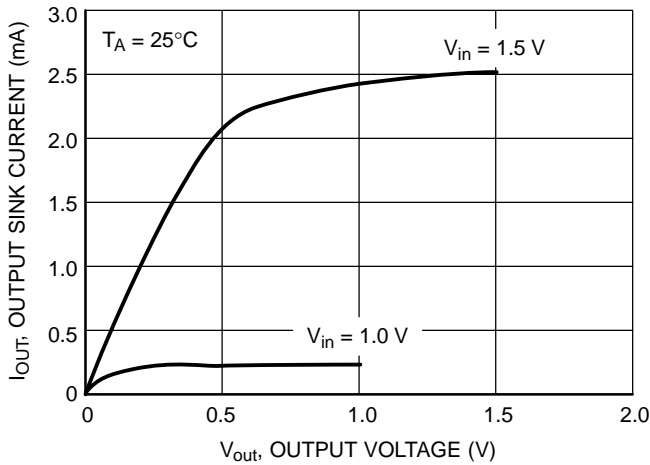

Figure 2. MAX707/708 Series 1.60 V Reset Output Sink Current vs. Output Voltage

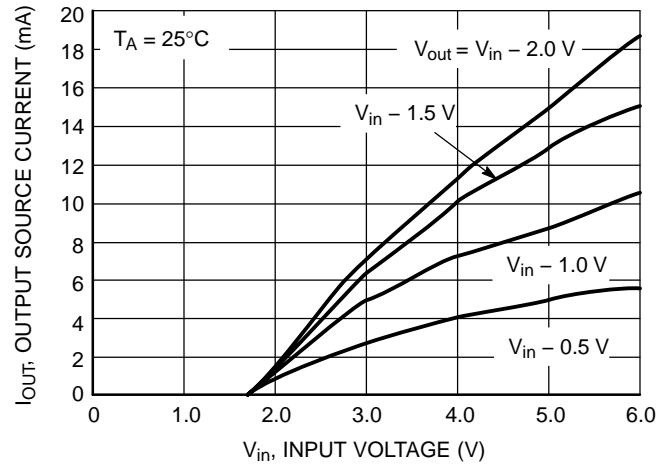

Figure 3. MAX707/708 Series 1.60 V Reset Output Source Current vs. Input Voltage

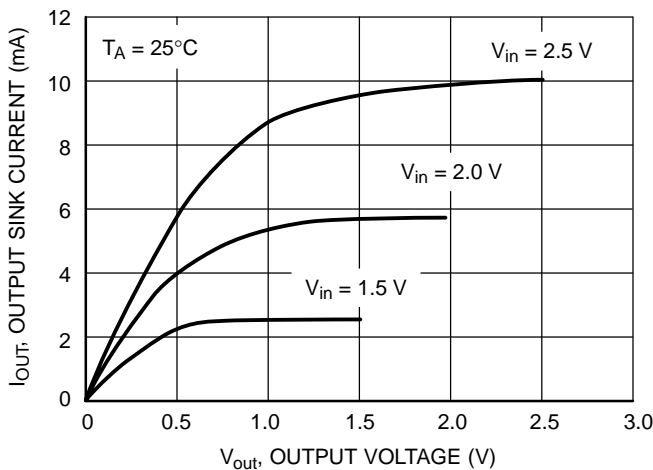

Figure 4. MAX707/708 Series 2.93 V Reset Output Sink Current vs. Output Voltage

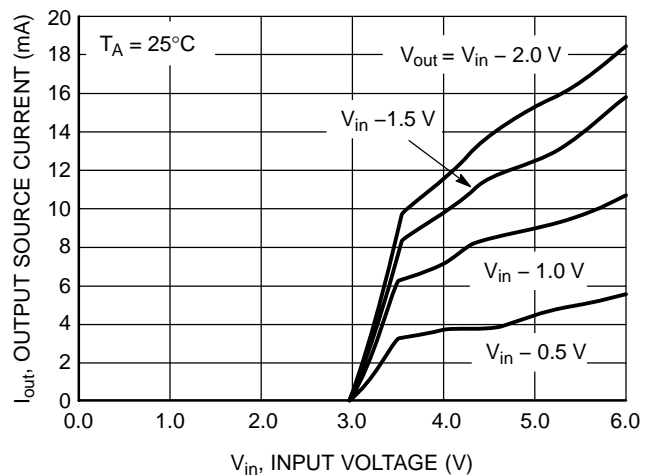

Figure 5. MAX707/708 Series 2.93 V Reset Output Source Current vs. Input Voltage

MAX707, MAX708

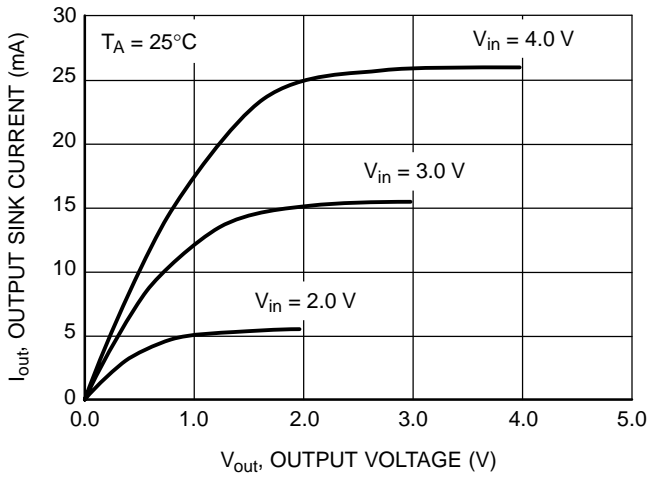

Figure 6. MAX707/708 Series 4.90 V Reset Output Sink Current vs. Output Voltage

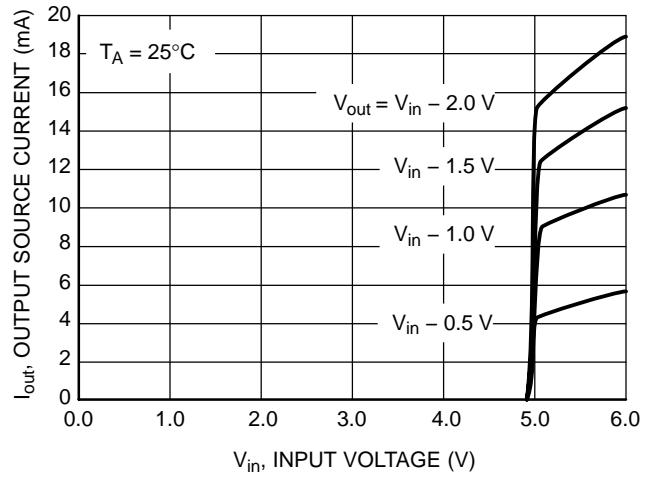

Figure 7. MAX707/708 Series 4.90 V Reset Output Source Current vs. Input Voltage

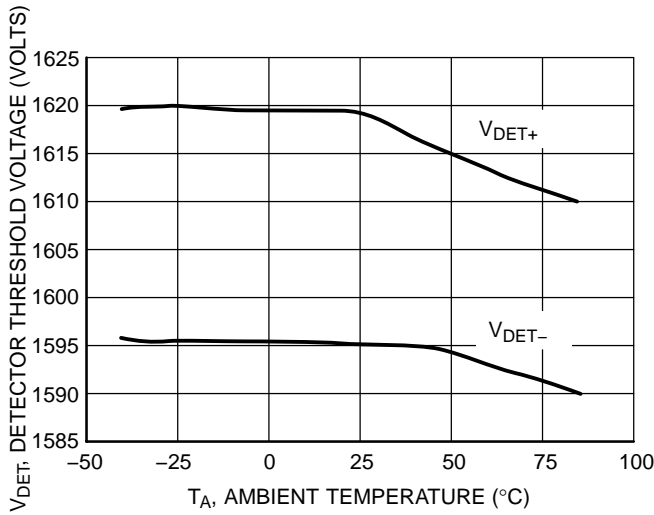

Figure 8. MAX707/708 Series 1.60 V Detector Threshold Voltage vs. Temperature

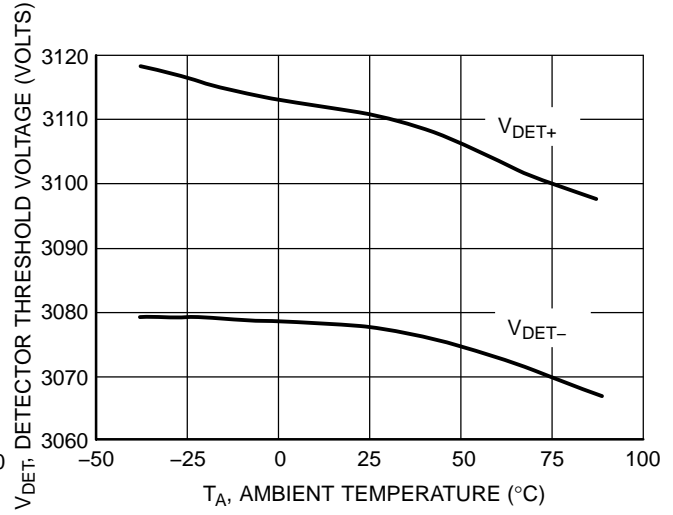

Figure 10. MAX707/708 Series 2.93 V Detector Threshold Voltage vs. Temperature

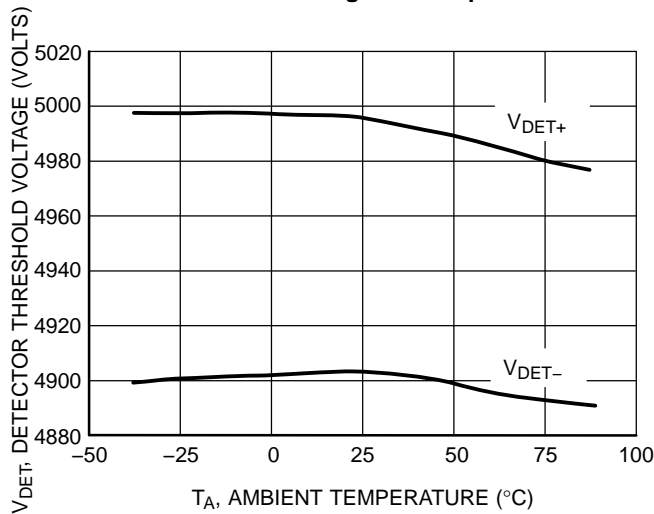

Figure 9. MAX707/708 Series 4.90 V Detector Threshold Voltage vs. Temperature

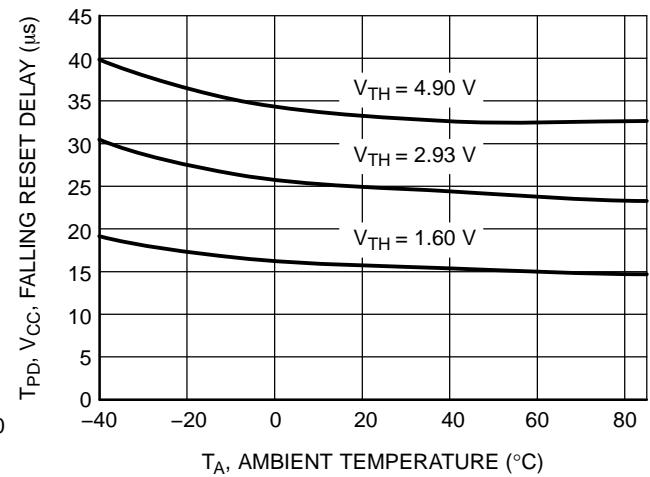

Figure 11. MAX707/708 Series V_{CC} Falling Reset Delay vs. Temperature

MAX707, MAX708

APPLICATIONS INFORMATION

Microprocessor Reset

To generate a processor reset, the manual Reset input allows different reset sources. A pushbutton switch can be

one of these. It is effectively debounced by the 1.0 μs minimum reset pulse width. As $\overline{\text{MR}}$ is TTL/CMOS logic compatible, it can be driven by an external logic line.

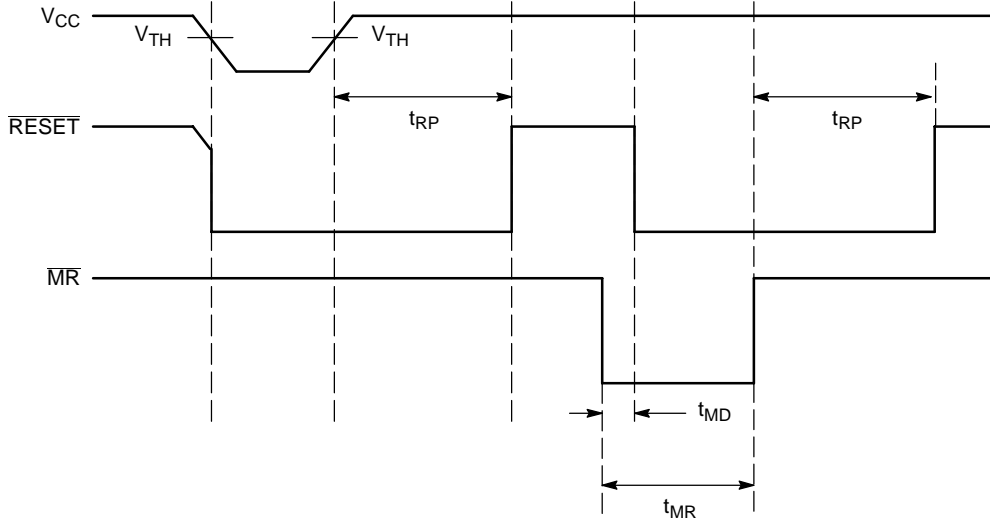

Figure 12. RESET and MR Timing

VCC Transient Rejection

The MAX707/708 provides accurate V_{CC} monitoring and reset timing during power-up, power-down, and brownout/sag conditions, and rejects negative glitches on the power supply line. Figure 13 shows the maximum transient duration vs. maximum negative excursion

(overdrive) for glitch rejection. For a given overdrive, the point of the curve is the maximum width of the glitch allowed before the device generates a reset signal. Transient immunity can be improved by adding a capacitor (100 nF for example) in close proximity to the V_{CC} pin of the MAX707/708.

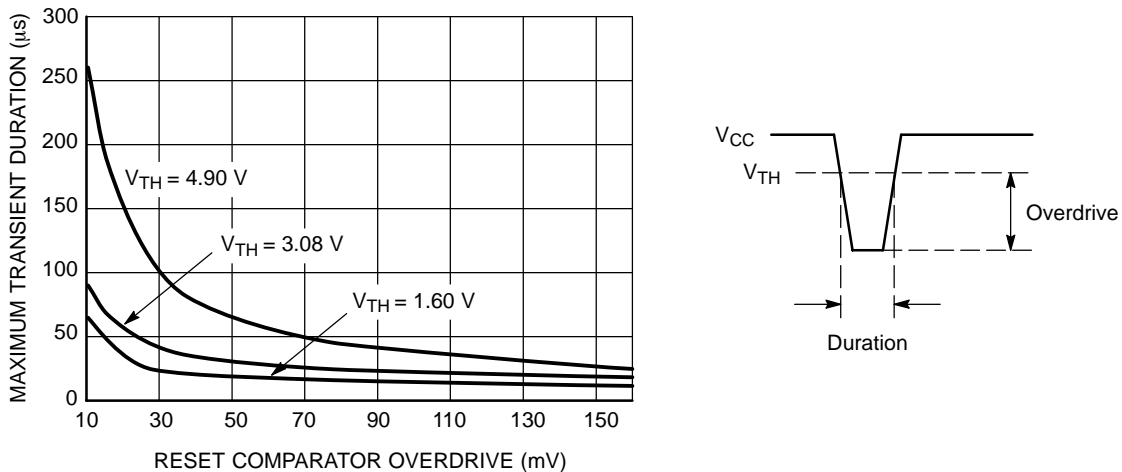

Figure 13. Maximum Transient Duration vs. Overdrive for Glitch Rejection at 25°C

RESET Signal Integrity During Power-Down

The MAX707/708 $\overline{\text{RESET}}$ output is valid until V_{CC} falls below 1.0 V. Then, the output becomes an open circuit and no longer sinks current. This means CMOS logic inputs of the μP will be floating at an undetermined voltage. Most digital systems are completely shutdown well above this voltage. However, in the case $\overline{\text{RESET}}$ must be maintained valid to $V_{CC} = 0\text{ V}$, a pull down resistor must be connected from $\overline{\text{RESET}}$ to ground to discharge stray capacitances and hold the output low (Figure 14). This resistor value, though not critical, should be chosen large enough not to load $\overline{\text{RESET}}$ and small enough to pull it to ground. $R = 100\text{ k}\Omega$ will be suitable for most applications.

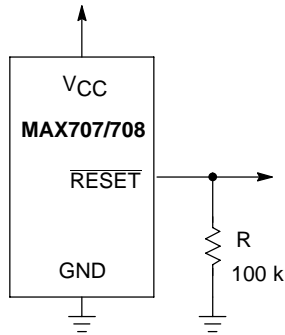

Figure 14. Ensuring $\overline{\text{RESET}}$ Valid to $V_{CC} = 0\text{ V}$

Interfacing with μPs with Bidirectional I/O Pins

Some μPs have bidirectional reset pins. If, for example, the $\overline{\text{RESET}}$ output is driven high and the μP wants to put it low, indeterminate logic level may result. This can be avoided by adding a 4.7 k Ω resistor in series with the output of the MAX707/708 (Figure 15). If there are other components in the system that require a reset signal, they should be buffered so as not to load the reset line.

components are required to follow the reset I/O of the μP , the buffer should be connected as shown with the solid line.

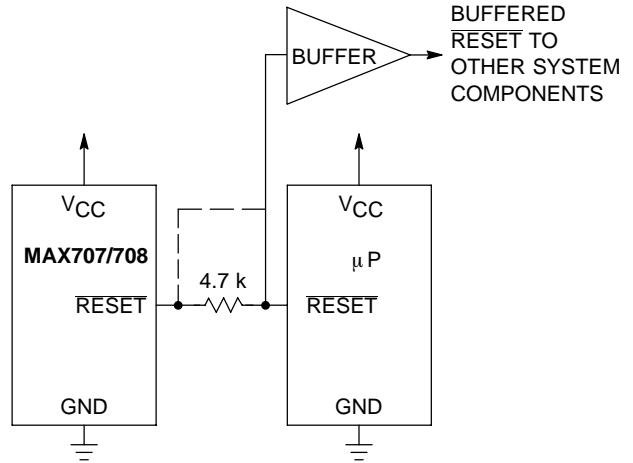
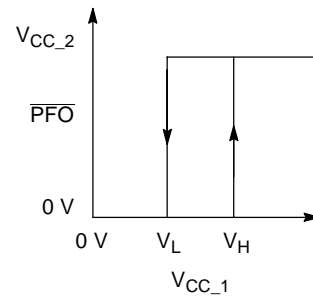
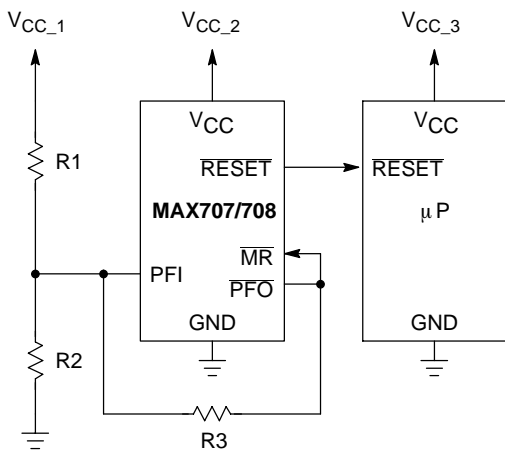

Figure 15. Interfacing to Bidirectional Reset I/O

Monitoring Additional Supply Levels

When connecting a voltage divider to PFI and adjusting it properly, you can monitor a voltage different than the unregulated DC one. As shown in Figure 16, to increase noise immunity, hysteresis may be added to the power-fail comparator just by a resistor between $\overline{\text{PFO}}$ and PFI. Not to unbalance the potential divider network, R3 should be 10 times the sum of the two resistors R1 and R2. If required, a capacitor between PFI and GND will reduce the sensitivity of the circuit to high-frequency noise on the line being monitored. The $\overline{\text{PFO}}$ output may be connected to $\overline{\text{MR}}$ input to generate a low level on the $\overline{\text{RESET}}$ when V_{CC_1} drops out of tolerance. Thus a $\overline{\text{RESET}}$ is generated when one of the two voltages is below its threshold level.



$$V_L = 1.25 + R1 \times \left(\frac{1.25}{R2} + \frac{1.25 - V_{CC_2}}{R3} \right)$$

$$V_H = 1.25 \times \left(1 + R1 \times \left(\frac{R2 + R3}{R2 \times R3} \right) \right)$$

$$V_{HYS} = V_H - V_L = \frac{R1 \times V_{CC_2}}{R3}$$

Figure 16. Monitoring Additional Supply Levels

MAX707, MAX708

ORDERING INFORMATION

Device	Marking	Reset V_{CC} Threshold (V)	Package	Shipping†
MAX707ESA-T	S707	4.63	SOIC-8	2500 Tape & Reel
MAX707ESA-TG	S707	4.63	SOIC-8 (Pb-Free)	2500 Tape & Reel
MAX708ESA-T	S708	4.38	SOIC-8	2500 Tape & Reel
MAX708ESA-TG	S708	4.38	SOIC-8 (Pb-Free)	2500 Tape & Reel
MAX708RESA-T	S708R	2.63	SOIC-8	2500 Tape & Reel
MAX708RESA-TG	S708R	2.63	SOIC-8 (Pb-Free)	2500 Tape & Reel
MAX708SESA-T	S708S	2.93	SOIC-8	2500 Tape & Reel
MAX708SESA-TG	S708S	2.93	SOIC-8 (Pb-Free)	2500 Tape & Reel
MAX708TESA-T	S708T	3.08	SOIC-8	2500 Tape & Reel
MAX708TESA-TG	S708T	3.08	SOIC-8 (Pb-Free)	2500 Tape & Reel
MAX707CUA-T	SAC	4.63	Micro8	4000 Tape & Reel
MAX707CUA-TG	SAC	4.63	Micro8 (Pb-Free)	4000 Tape & Reel
MAX708CUA-T	SAD	4.38	Micro8	4000 Tape & Reel
MAX708CUA-TG	SAD	4.38	Micro8 (Pb-Free)	4000 Tape & Reel
MAX708RCUA-T	SAG	2.63	Micro8	4000 Tape & Reel
MAX708RCUA-TG	SAG	2.63	Micro8 (Pb-Free)	4000 Tape & Reel
MAX708SCUA-T	SAF	2.93	Micro8	4000 Tape & Reel
MAX708SCUA-TG	SAF	2.93	Micro8 (Pb-Free)	4000 Tape & Reel
MAX708TCUA-T	SAE	3.08	Micro8	4000 Tape & Reel
MAX708TCUA-TG	SAE	3.08	Micro8 (Pb-Free)	4000 Tape & Reel

†For information on tape and reel specifications, including part orientation and tape sizes, please refer to our Tape and Reel Packaging Specifications Brochure, BRD8011/D.

MAX707, MAX708

PACKAGE DIMENSIONS

Micro8
CASE 846A-02
ISSUE F

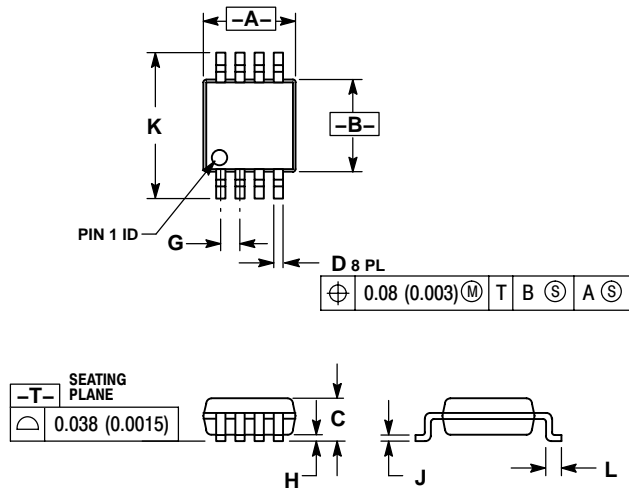

NOTES:

1. DIMENSIONING AND TOLERANCING PER ANSI Y14.5M, 1982.
2. CONTROLLING DIMENSION: MILLIMETER.
3. DIMENSION A DOES NOT INCLUDE MOLD FLASH, PROTRUSIONS OR GATE BURRS. MOLD FLASH, PROTRUSIONS OR GATE BURRS SHALL NOT EXCEED 0.15 (0.006) PER SIDE.
4. DIMENSION B DOES NOT INCLUDE INTERLEAD FLASH OR PROTRUSION. INTERLEAD FLASH OR PROTRUSION SHALL NOT EXCEED 0.25 (0.010) PER SIDE.
5. 846A-01 OBSOLETE, NEW STANDARD 846A-02.

DIM	MILLIMETERS		INCHES	
	MIN	MAX	MIN	MAX
A	2.90	3.10	0.114	0.122
B	2.90	3.10	0.114	0.122
C	---	1.10	---	0.043
D	0.25	0.40	0.010	0.016
G	0.65 BSC		0.026 BSC	
H	0.05	0.15	0.002	0.006
J	0.13	0.23	0.005	0.009
K	4.75	5.05	0.187	0.199
L	0.40	0.70	0.016	0.028

SOLDERING FOOTPRINT*

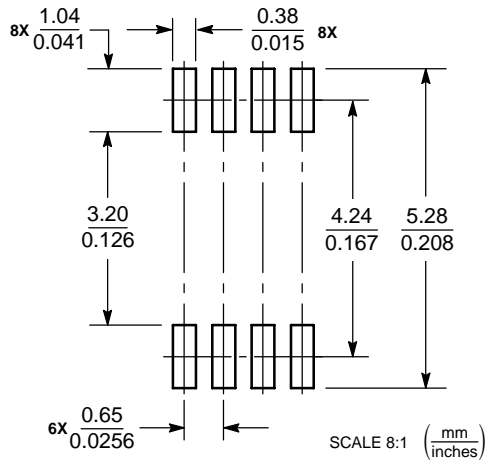

*For additional information on our Pb-Free strategy and soldering details, please download the ON Semiconductor Soldering and Mounting Techniques Reference Manual, SOLDERRM/D.

MAX707, MAX708

PACKAGE DIMENSIONS

SOIC-8
CASE 751-07
ISSUE AG

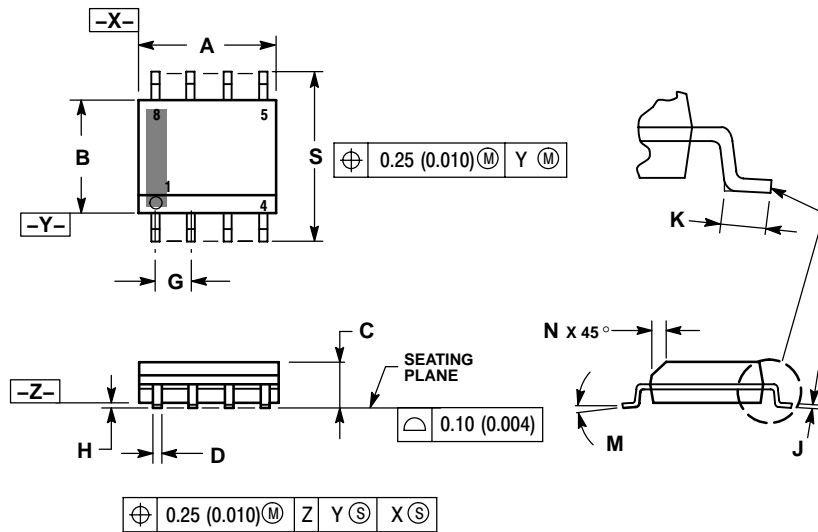

NOTES:

1. DIMENSIONING AND TOLERANCING PER ANSI Y14.5M, 1982.
2. CONTROLLING DIMENSION: MILLIMETER.
3. DIMENSION A AND B DO NOT INCLUDE MOLD PROTRUSION.
4. MAXIMUM MOLD PROTRUSION 0.15 (0.006) PER SIDE.
5. DIMENSION D DOES NOT INCLUDE DAMBAR PROTRUSION. ALLOWABLE DAMBAR PROTRUSION SHALL BE 0.127 (0.005) TOTAL IN EXCESS OF THE D DIMENSION AT MAXIMUM MATERIAL CONDITION.
6. 751-01 THRU 751-06 ARE OBSOLETE. NEW STANDARD IS 751-07.

DIM	MILLIMETERS		INCHES	
	MIN	MAX	MIN	MAX
A	4.80	5.00	0.189	0.197
B	3.80	4.00	0.150	0.157
C	1.35	1.75	0.053	0.069
D	0.33	0.51	0.013	0.020
G	1.27 BSC		0.050 BSC	
H	0.10	0.25	0.004	0.010
J	0.19	0.25	0.007	0.010
K	0.40	1.27	0.016	0.050
M	0°	8°	0°	8°
N	0.25	0.50	0.010	0.020
S	5.80	6.20	0.228	0.244

SOLDERING FOOTPRINT*

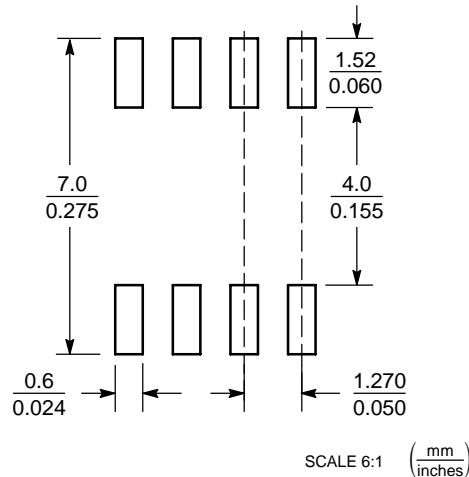

*For additional information on our Pb-Free strategy and soldering details, please download the ON Semiconductor Soldering and Mounting Techniques Reference Manual, SOLDERRM/D.

Micro8 is a trademark of International Rectifier.

ON Semiconductor and are registered trademarks of Semiconductor Components Industries, LLC (SCILLC). SCILLC reserves the right to make changes without further notice to any products herein. SCILLC makes no warranty, representation or guarantee regarding the suitability of its products for any particular purpose, nor does SCILLC assume any liability arising out of the application or use of any product or circuit, and specifically disclaims any and all liability, including without limitation special, consequential or incidental damages. "Typical" parameters which may be provided in SCILLC data sheets and/or specifications can and do vary in different applications and actual performance may vary over time. All operating parameters, including "Typicals" must be validated for each customer application by customer's technical experts. SCILLC does not convey any license under its patent rights nor the rights of others. SCILLC products are not designed, intended, or authorized for use as components in systems intended for surgical implant into the body, or other applications intended to support or sustain life, or for any other application in which the failure of the SCILLC product could create a situation where personal injury or death may occur. Should Buyer purchase or use SCILLC products for any such unintended or unauthorized application, Buyer shall indemnify and hold SCILLC and its officers, employees, subsidiaries, affiliates, and distributors harmless against all claims, costs, damages, and expenses, and reasonable attorney fees arising out of, directly or indirectly, any claim of personal injury or death associated with such unintended or unauthorized use, even if such claim alleges that SCILLC was negligent regarding the design or manufacture of the part. SCILLC is an Equal Opportunity/Affirmative Action Employer. This literature is subject to all applicable copyright laws and is not for resale in any manner.

PUBLICATION ORDERING INFORMATION

LITERATURE FULFILLMENT:
Literature Distribution Center for ON Semiconductor
P.O. Box 61312, Phoenix, Arizona 85082-1312 USA
Phone: 480-829-7710 or 800-344-3860 Toll Free USA/Canada
Fax: 480-829-7709 or 800-344-3867 Toll Free USA/Canada
Email: orderlit@onsemi.com

N. American Technical Support: 800-282-9855 Toll Free
USA/Canada

Japan: ON Semiconductor, Japan Customer Focus Center
2-9-1 Kamimeguro, Meguro-ku, Tokyo, Japan 153-0051
Phone: 81-3-5773-3850

ON Semiconductor Website: <http://onsemi.com>

Order Literature: <http://www.onsemi.com/litorder>

For additional information, please contact your local Sales Representative.