



# **PICDEM™ System Management USER'S GUIDE**

# PICDEM SYSTEM MANAGEMENT

---

## Note the following details of the code protection feature on Microchip devices:

- Microchip products meet the specification contained in their particular Microchip Data Sheet.
- Microchip believes that its family of products is one of the most secure families of its kind on the market today, when used in the intended manner and under normal conditions.
- There are dishonest and possibly illegal methods used to breach the code protection feature. All of these methods, to our knowledge, require using the Microchip products in a manner outside the operating specifications contained in Microchip's Data Sheets. Most likely, the person doing so is engaged in theft of intellectual property.
- Microchip is willing to work with the customer who is concerned about the integrity of their code.
- Neither Microchip nor any other semiconductor manufacturer can guarantee the security of their code. Code protection does not mean that we are guaranteeing the product as "unbreakable."

Code protection is constantly evolving. We at Microchip are committed to continuously improving the code protection features of our products. Attempts to break Microchip's code protection feature may be a violation of the Digital Millennium Copyright Act. If such acts allow unauthorized access to your software or other copyrighted work, you may have a right to sue for relief under that Act.

Information contained in this publication regarding device applications and the like is provided only for your convenience and may be superseded by updates. It is your responsibility to ensure that your application meets with your specifications. MICROCHIP MAKES NO REPRESENTATIONS OR WARRANTIES OF ANY KIND WHETHER EXPRESS OR IMPLIED, WRITTEN OR ORAL, STATUTORY OR OTHERWISE, RELATED TO THE INFORMATION, INCLUDING BUT NOT LIMITED TO ITS CONDITION, QUALITY, PERFORMANCE, MERCHANTABILITY OR FITNESS FOR PURPOSE. Microchip disclaims all liability arising from this information and its use. Use of Microchip devices in life support and/or safety applications is entirely at the buyer's risk, and the buyer agrees to defend, indemnify and hold harmless Microchip from any and all damages, claims, suits, or expenses resulting from such use. No licenses are conveyed, implicitly or otherwise, under any Microchip intellectual property rights.

## Trademarks

The Microchip name and logo, the Microchip logo, Accuron, dsPIC, KEELOQ, KEELOQ logo, microID, MPLAB, PIC, PICmicro, PICSTART, PRO MATE, PowerSmart, rfPIC, and SmartShunt are registered trademarks of Microchip Technology Incorporated in the U.S.A. and other countries.

AmpLab, FilterLab, Linear Active Thermistor, Migratable Memory, MXDEV, MXLAB, PS logo, SEEVAL, SmartSensor and The Embedded Control Solutions Company are registered trademarks of Microchip Technology Incorporated in the U.S.A.

Analog-for-the-Digital Age, Application Maestro, CodeGuard, dsPICDEM, dsPICDEM.net, dsPICworks, ECAN, ECONOMONITOR, FanSense, FlexROM, fuzzyLAB, In-Circuit Serial Programming, ICSP, ICEPIC, Mindi, MiWi, MPASM, MPLAB Certified logo, MPLIB, MPLINK, PICKit, PICDEM, PICDEM.net, PICLAB, PICtail, PowerCal, PowerInfo, PowerMate, PowerTool, REAL ICE, rFLAB, rfPICDEM, Select Mode, Smart Serial, SmartTel, Total Endurance, UNI/O, WiperLock and ZENA are trademarks of Microchip Technology Incorporated in the U.S.A. and other countries.

SQTP is a service mark of Microchip Technology Incorporated in the U.S.A.

All other trademarks mentioned herein are property of their respective companies.

© 2007, Microchip Technology Incorporated, Printed in the U.S.A., All Rights Reserved.

 Printed on recycled paper.

*Microchip received ISO/TS-16949:2002 certification for its worldwide headquarters, design and wafer fabrication facilities in Chandler and Tempe, Arizona, Gresham, Oregon and Mountain View, California. The Company's quality system processes and procedures are for its PIC<sup>®</sup> MCUs and dsPIC<sup>®</sup> DSCs, KEELOQ<sup>®</sup> code hopping devices, Serial EEPROMs, microperipherals, nonvolatile memory and analog products. In addition, Microchip's quality system for the design and manufacture of development systems is ISO 9001:2000 certified.*

**QUALITY MANAGEMENT SYSTEM**  
**CERTIFIED BY DNV**  
**== ISO/TS 16949:2002 ==**

**Table of Contents**

**Preface** ..... 1

**Chapter 1. PICDEM™ System Management**

    1.1 Introduction ..... 7

    1.2 Highlights ..... 7

    1.3 PICDEM™ System Management Kit Contents ..... 7

    1.4 PICDEM System Management Layout ..... 8

        1.4.1 Board Features ..... 8

        1.4.2 Board Connections ..... 8

        1.4.3 Heating Element ..... 10

        1.4.4 Board Options ..... 10

    1.5 Quick Start Guide ..... 10

        1.5.1 Demonstration Program ..... 10

        1.5.2 Real-Time Clock: Address 0xA2 ..... 11

        1.5.3 Analog-to-Digital Converter (ADC): Address 0xA4 ..... 11

        1.5.4 Serial EEPROM: Address 0xA8 ..... 12

        1.5.5 Thermal Management: Address 0xA6 ..... 12

        1.5.6 General I<sup>2</sup>C™ ..... 13

**Chapter 2. Background**

    2.1 Introduction ..... 15

    2.2 Highlights ..... 15

    2.3 PICDEM™ System Management and PICKit™ Serial Analyzer ..... 15

    2.4 Fan Speed Control ..... 15

        2.4.1 Two-wire Fan ..... 15

        2.4.2 Three-wire Fan ..... 16

        2.4.3 Measuring the Speed of a Two and Three-wire Fan ..... 16

        2.4.4 Four-wire Fan Control ..... 17

**Chapter 3. Troubleshooting**

    3.1 Introduction ..... 19

    3.2 Common Problems ..... 19

        3.2.1 Serial Communications does not appear to be working ..... 19

        3.2.2 Microcontroller does not run after programming using the  
            MPLAB® ICD 2 ..... 19

        3.2.3 The fan is not providing proper feedback ..... 19

        3.2.4 Heating element is not heating ..... 19

        3.2.5 Temperature is not changing ..... 19

# PICDEM™ System Management User's Guide

---

---

## Appendix A. Hardware Schematics

A.1 Introduction ..... 21

## Appendix B. Register Maps

B.1 Introduction ..... 23

**Worldwide Sales and Service ..... 28**



# PICDEM™ SYSTEM MANAGEMENT USER'S GUIDE

---

---

## Preface

---

---

### NOTICE TO CUSTOMERS

All documentation becomes dated, and this manual is no exception. Microchip tools and documentation are constantly evolving to meet customer needs, so some actual dialogs and/or tool descriptions may differ from those in this document. Please refer to our web site ([www.microchip.com](http://www.microchip.com)) to obtain the latest documentation available.

Documents are identified with a “DS” number. This number is located on the bottom of each page, in front of the page number. The numbering convention for the DS number is “DSXXXXA”, where “XXXX” is the document number and “A” is the revision level of the document.

For the most up-to-date information on development tools, see the MPLAB® IDE on-line help. Select the Help menu, and then Topics to open a list of available on-line help files.

## INTRODUCTION

This chapter contains general information that will be useful to know before using the PICDEM™ System Management Board. Items discussed in this chapter include:

- Document Layout
- Conventions Used in this Guide
- Warranty Registration
- Recommended Reading
- The Microchip Web Site
- Development Systems Customer Change Notification Service
- Customer Support
- Document Revision History

## DOCUMENT LAYOUT

This document describes how to use the PICDEM™ System Management Board as a demonstration and training platform tool. The manual layout is as follows:

- **Chapter 1. “PICDEM™ System Management”** – This chapter provides an overview of the PICDEM System Management Board and system integration.
- **Chapter 2. “Background”** – This chapter provides background information on the System Management application and the PICDEM System Management Board.
- **Chapter 3. “Troubleshooting”** – This chapter provides resolutions for solving common problems associated with using the PICDEM System Management Board.
- **Appendix A. “Hardware Schematics”** – Illustrates the PICDEM System Management Board hardware schematic diagram.

# PICDEM™ System Management User's Guide

## CONVENTIONS USED IN THIS GUIDE

This manual uses the following documentation conventions:

### DOCUMENTATION CONVENTIONS

Description	Represents	Examples
<b>Arial font:</b>		
Italic characters	Referenced books	"MPLAB® IDE User's Guide"
	Emphasized text	...is the <i>only</i> compiler...
Initial caps	A window	the Output window
	A dialog	the Settings dialog
	A menu selection	select Enable Programmer
Quotes	A field name in a window or dialog	"Save project before build"
Underlined, italic text with right angle bracket	A menu path	<u>File</u> >Save
Bold characters	A dialog button	Click <b>OK</b>
	A tab	Click the <b>Power</b> tab
N'Rnnnn	A number in verilog format, where N is the total number of digits, R is the radix and n is a digit.	4'b0010, 2'hF1
Text in angle brackets < >	A key on the keyboard	Press <Enter>, <F1>
<b>Courier New font:</b>		
Plain Courier New	Sample source code	#define START
	Filenames	autoexec.bat
	File paths	c:\mcc18\h
	Keywords	_asm, _endasm, static
	Command-line options	-Opa+, -Opa-
	Bit values	0, 1
	Constants	0xFF, 'A'
Italic Courier New	A variable argument	<i>file.o</i> , where <i>file</i> can be any valid filename
Square brackets [ ]	Optional arguments	mcc18 [options] <i>file</i> [options]
Curly brackets and pipe character: {   }	Choice of mutually exclusive arguments; an OR selection	errorlevel {0 1}
Ellipses...	Replaces repeated text	var_name [, var_name...]
	Represents code supplied by user	void main (void) { ... }

## WARRANTY REGISTRATION

Please complete the enclosed Warranty Registration Card and mail it promptly. Sending in the Warranty Registration Card entitles users to receive new product updates. Interim software releases are available at the Microchip web site.

## RECOMMENDED READING

This user's guide describes how to use the PICDEM™ System Management Board. Other useful documents are listed below. The following Microchip documents are available and recommended as supplemental reference resources. To obtain these documents, contact the nearest Microchip sales location (see back page). These documents are also available on the Microchip web site at: [www.microchip.com](http://www.microchip.com).

### **PICKit™ Serial Analyzer User's Guide (DS51647)**

Consult this document for information how to use the PICKit™ Serial Analyzer. (This document is included with the PICDEM System Management Board kit.)

### **PICKit™ 2 Microcontroller Programmer User's Guide (DS51553)**

Consult this document for instructions on how to use the PICKit™ 2 Microcontroller Programmer software and hardware.

### **MPLAB® IDE, Simulator, Editor User's Guide (DS51025)**

Consult this document for more information pertaining to the installation and features of the MPLAB Integrated Development Environment (IDE) Software.

### **PIC16F886 Data Sheet (DS41291)**

Consult this document for information regarding the PIC16F886 28/40/44-Pin Flash-Based, 8-Bit CMOS Microcontrollers with nanoWatt Technology device specifications.

### **MCP9700/9700A/9701/9701 Low-Power Linear Active Thermistor™ ICs (DS21942)**

Consult this document for information regarding the MCP9700 Analog Temperature Sensor.

### **Readme Files**

For the latest information on using other tools, read the tool-specific Readme files in the Readmes subdirectory of the MPLAB IDE installation directory. The Readme files contain updated information and known issues that may not be included in this user's guide.

## THE MICROCHIP WEB SITE

Microchip provides online support via our web site at [www.microchip.com](http://www.microchip.com). This web site is used as a means to make files and information easily available to customers. Accessible by using your favorite Internet browser, the web site contains the following information:

- **Product Support** – Data sheets and errata, application notes and sample programs, design resources, user's guides and hardware support documents, latest software releases and archived software
- **General Technical Support** – Frequently Asked Questions (FAQs), technical support requests, online discussion groups, Microchip consultant program member listing
- **Business of Microchip** – Product selector and ordering guides, latest Microchip press releases, listing of seminars and events, listings of Microchip sales offices, distributors and factory representatives

## DEVELOPMENT SYSTEMS CUSTOMER CHANGE NOTIFICATION SERVICE

Microchip's customer notification service helps keep customers current on Microchip products. Subscribers will receive e-mail notification whenever there are changes, updates, revisions or errata related to a specified product family or development tool of interest.

To register, access the Microchip web site at [www.microchip.com](http://www.microchip.com), click on **Customer Change Notification** and follow the registration instructions.

The Development Systems product group categories are:

- **Compilers** – The latest information on Microchip C compilers and other language tools. These include the MPLAB C18 and MPLAB C30 C compilers; MPASM™ and MPLAB ASM30 assemblers; MPLINK™ and MPLAB LINK30 object linkers; and MPLIB™ and MPLAB LIB30 object librarians.
- **Emulators** – The latest information on Microchip in-circuit emulators. This includes the MPLAB ICE 2000, MPLAB ICE 4000 and REAL ICE™.
- **In-Circuit Debuggers** – The latest information on the Microchip in-circuit debugger, MPLAB ICD 2.
- **MPLAB® IDE** – The latest information on Microchip MPLAB IDE, the Windows® Integrated Development Environment for development systems tools. This list is focused on the MPLAB IDE, MPLAB SIM simulator, MPLAB IDE Project Manager and general editing and debugging features.
- **Programmers** – The latest information on Microchip programmers. These include the MPLAB PM3 and PRO MATE® II device programmers and the PICSTART® Plus and PICkit™ 2 development programmers.



## CUSTOMER SUPPORT

Users of Microchip products can receive assistance through several channels:

- Distributor or Representative
- Local Sales Office
- Field Application Engineer (FAE)
- Technical Support

Customers should contact their distributor, representative or field application engineer (FAE) for support. Local sales offices are also available to help customers. A listing of sales offices and locations is included in the back of this document.

Technical support is available through the web site at: <http://support.microchip.com>

## DOCUMENT REVISION HISTORY

### Revision A (December 2006)

- Initial release of this document.

### Revision B (January 2007)

- Updated Chapter 1.
- Updated Preface by adding the PICkit™ Serial Analyzer User Guide DS number.

## TROUBLESHOOTING

See **Chapter 3. “Troubleshooting”** for information on common problems.

# PICDEM™ System Management User's Guide

---

---

NOTES:

---

---

## Chapter 1. PICDEM™ System Management

---

---

### 1.1 INTRODUCTION

The PICDEM™ System Management Board is a demonstration and development tool designed for system management applications. System management applications monitor platform physical health characteristics such as temperatures, voltage, fan speed and chassis intrusion. These applications typically utilize independent I<sup>2</sup>C™ devices like real-time clocks, EEPROMs, Analog-to-Digital Converters (ADC), and thermal management controllers to monitor and control physical health characteristics. The PICDEM™ System Management Board demonstrates how PIC® microcontrollers can add value to these applications in terms of flexibility and cost. I<sup>2</sup>C devices can be implemented using the Synchronous Serial Port module in conjunction with the many other available peripherals. The programmability of a microcontroller I<sup>2</sup>C device allows flexibility in the additional intelligent features that can be implemented as well as the easy adaptability of software when requirements change. A new address masking feature of the Synchronous Serial Port module allows the microcontroller to respond to multiple I<sup>2</sup>C device addresses. The PICDEM™ System Management uses this feature to implement four I<sup>2</sup>C devices: a real-time clock, ADC, EEPROM, and thermal management controller on one single microcontroller. Integrating these functions on a single microcontroller provides savings in the bill of materials cost and board space. For additional information on system monitoring, see **Chapter 2. “Background”** of this User's Guide.

### 1.2 HIGHLIGHTS

This chapter discusses the features of the PICDEM™ System Management Board Kit. Topics discussed include:

- PICDEM™ System Management Kit Contents
- PICDEM™ System Management Layout
- Quick Start Guide
- Demonstration Program

### 1.3 PICDEM™ SYSTEM MANAGEMENT KIT CONTENTS

The PICDEM™ System Management kit includes the following items:

1. The PICDEM™ System Management printed circuit board with 3-wire fan
2. The PICkit™ Serial Analyzer
3. PICDEM™ System Management CD-ROM, which includes:
  - a) PICDEM™ System Management User's Guide
  - b) PICDEM™ System Management GUI
  - c) PICDEM™ System Management Board schematic
  - d) PICDEM™ System Management Source Code
  - e) PICDEM™ System Management Workshop slides
4. PICkit™ Serial Analyzer CD-ROM
5. +12V power supply

If you are missing any part of the kit, please contact your nearest Microchip sales office listed in the back of this publication for help.

# PICDEM™ System Management User's Guide

## 1.4 PICDEM SYSTEM MANAGEMENT LAYOUT

### 1.4.1 Board Features

The PICDEM™ System Management board is populated with a PIC16F886 microcontroller. The PIC16F886 connects to the following board features:

- $\overline{\text{MCLR}}$  switch, interrupt switch
- 4 LEDs
- I<sup>2</sup>C™ communications (SDA and SCL)
- USART communications (TX and RX)
- ICSP™ programming pins (ICSPDAT and ICSPCLK)
- PWM output fan control
- Fan tachometer input line
- Heating element control line
- Temperature sensor input line from MCP9700
- 32.768 kHz crystal clock (T1OSO and T1OSI)
- Battery voltage measurement enable, input line and interrupt-on-change pin

### 1.4.2 Board Connections

The PICDEM™ System Management is populated with connectors for programming, communications, and fan control and a temperature sensor, shown in Figure 1-1. A description of the connectors and the temperature sensor is described below.

FIGURE 1-1: PICDEM™ SYSTEM MANAGEMENT BOARD

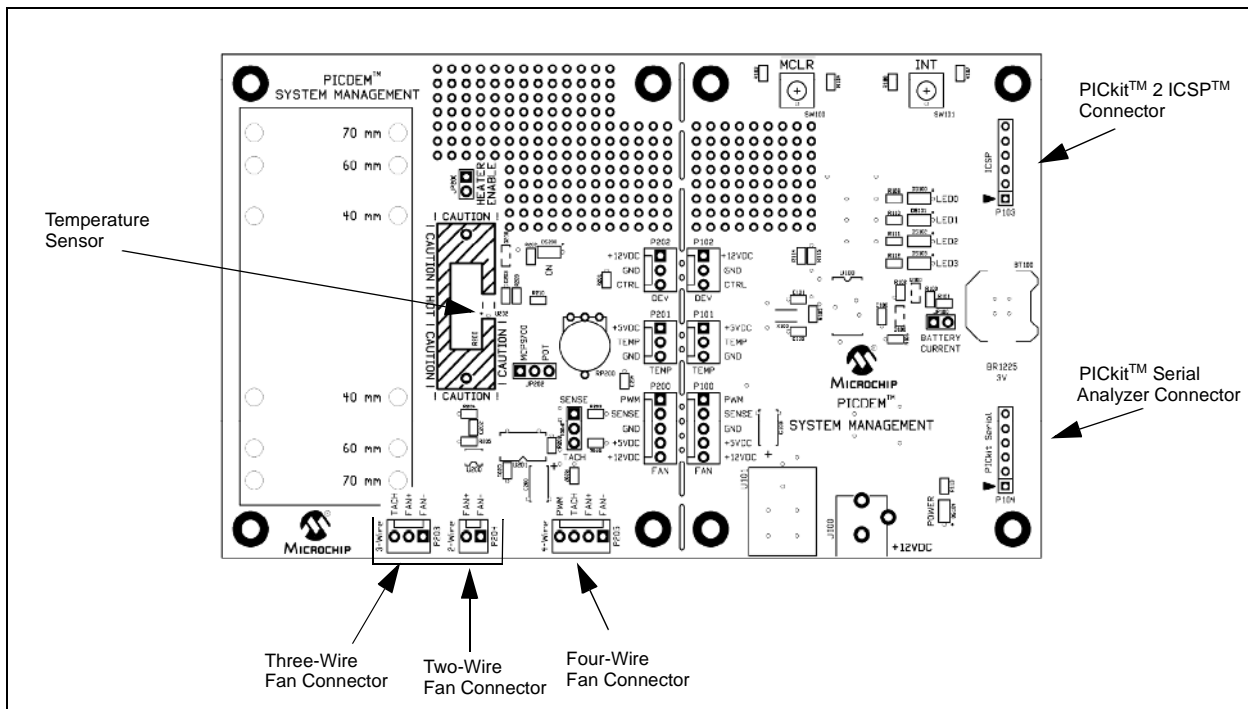

- **PICKit™ 2 ICSP™ (In-Circuit Serial Programmer™) Connector** – A 6-pin ICSP connector is provided for programming the PIC16F886. The PIC16F886 can be programmed through this connector with the PICKit 2 programmer, or the MPLAB ICD 2 using the RJ-11 to ICSP adapter (AC164110).
- **PICKit™ Serial Analyzer Connector** – The PICKit™ Serial Analyzer connector provides pins for serial communication. The serial communications lines are designed to be used with the PICKit Serial Analyzer, but can also be used for other communications applications. The serial communication pinout lines are shown in Figure 1-2.

**FIGURE 1-2: PICKit™ SERIAL ANALYZER PINOUT**

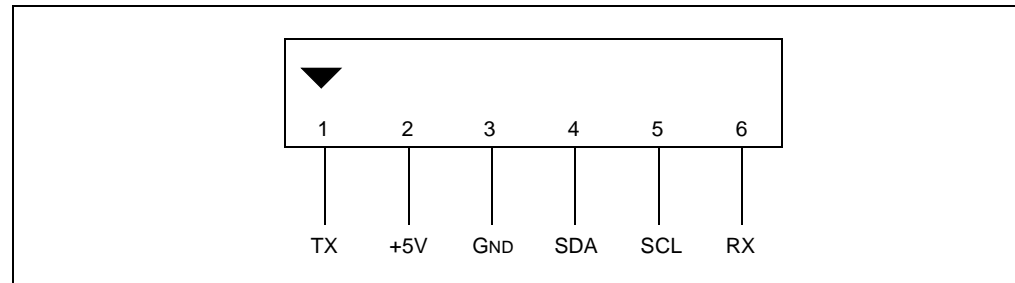

- **Two-Wire Fan Connector** – The two-wire fan connector (P204) provides power and ground terminals for a two-wire fan. In order to make speed measurements, jumper JP200 must be set in the “SENSE” position for two-wire fans.
- **Three-Wire Fan Connector** – The three-wire fan (P203) connector provides power and ground with a tachometer line for speed measurements. Jumper JP201 must be set in the “TACH” position to measure speed on three-wire fans. Additional background on driving two-wire and three-wire fans is provided in **Section Chapter 2. “Background”** of this document.
- **Four-Wire Fan Connector** – A four-wire fan connector (P205) is mounted on the board and provides power, ground, tachometer and pulse-width modulation terminals. In order to measure the speed of the four-wire fan, the JP201 jumper must be set to the “TACH” position. Additional background information on driving four-wire fans is provided in **Section Chapter 2. “Background”** of this document.
- **Temperature Sensor** – An MCP9700 temperature sensor is located near the heating element of the PICDEM System Management Board. The MCP9700 is an analog temperature sensor that converts temperature into an analog voltage. In order to measure temperature, the JP202 jumper must be set to the “MCP9700” position.

Temperature can also be simulated with the potentiometer that is populated on the board. The circuit has been designed so that the temperature range of the MCP9700 can be simulated. In order to simulate temperature with the potentiometer, the JP202 jumper must be set to the “POT” position.

## 1.4.3 Heating Element

A resistor is used as a heating element to generate heat near the MCP9700 temperature sensor to simulate a thermal system. To activate the heating element, set the CTRL line (RA3) high. Once, the heating element is active, the ON LED will light up. In order to operate the heating element, JP200, heater enable jumper, must be in place.

### WARNING

**The heating element will be very hot when on. Do not activate the heating element unless the fan is running. Always disconnect JP200 after use and allow the heating element to cool.**

## 1.4.4 Board Options

The PICDEM™ System Management Board is scribed and can be separated into two separate boards.

The fan control board contains the connectors for two, three and four-wire fans in addition to the control, power and ground lines for the heating element and temperature sensor, as well as the fan drive circuitry.

The main board contains the PIC16F866, power input, push-buttons, LEDs, battery backup circuit and connectors that break out the fan control, temperature sensor and heating element pins. These elements can be used in conjunction with the prototyping area for development.

## 1.5 QUICK START GUIDE

The PICDEM™ System Management Board is preloaded with demonstration firmware. The board must be configured as described in this section in order to use the demonstration program. For details on firmware, please review the System Management presentation included on the CD-ROM.

### Board Setup

1. Connect the 3-wire fan to the 3-wire fan connector labeled "3-wire".
2. Place the JP201 jumper on the bottom setting, connecting "TACH" to the middle pin.
3. Connect the J200 jumper to allow the heating element to be turned on.
4. Plug the PICKit Serial Analyzer into the PICDEM System Management Board on the pins marked "PICKit Serial" (P104).
5. Plug the PICKit Serial Analyzer USB cable into a compatible PC.

### Board Power-Up

Connect the provided +12V power supply to J100.

### 1.5.1 Demonstration Program

1. Insert the included PICDEM System Management CD into the CD drive.
2. Run the installation software for the PICDEM System Management GUI (D:\Setup\Setup.exe).
3. Run the System Management program (start <Programs><Microchip System Management Board>).

Within this screen there are several tabs that allow control and monitoring of various functions.

## 1.5.2 Real-Time Clock: Address 0xA2

The **Real-Time Clock** function reads and writes actual time data on the PIC16F886. The time base is generated using a 32.768 kHz external Timer1 crystal. This time is automatically refreshed and can be changed in the GUI software.

**FIGURE 1-3: REAL-TIME CLOCK**

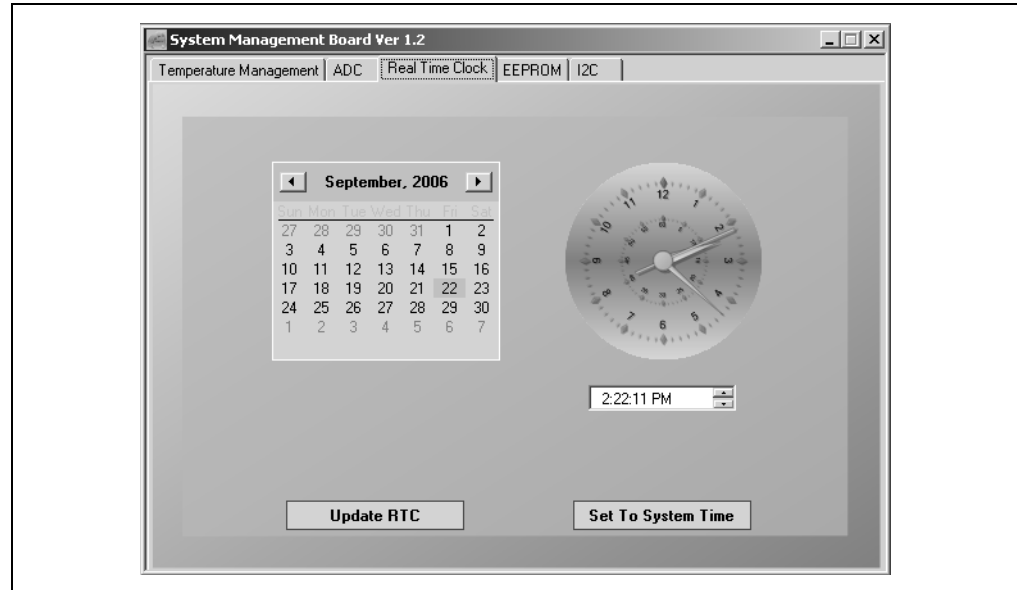

## 1.5.3 Analog-to-Digital Converter (ADC): Address 0xA4

The **ADC** function provides Analog-to-Digital conversion of the voltage drop through potentiometer RP200. As you turn the potentiometer, the voltage indicator should change. Jumper JP202 must connect to the middle pin and the pin labeled "POT."

**FIGURE 1-4: ANALOG-TO-DIGITAL CONVERTER (ADC)**

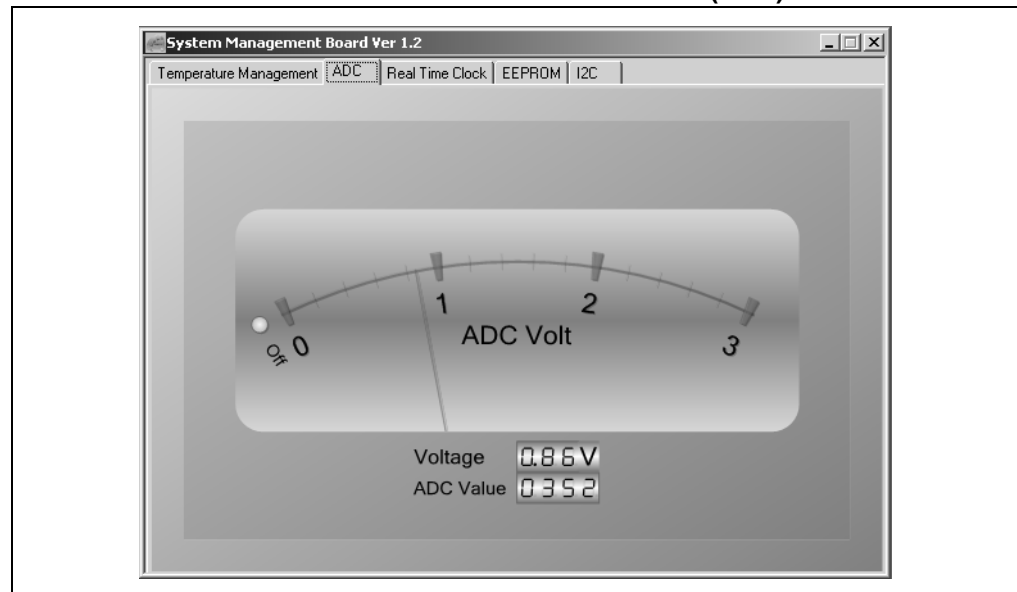

## 1.5.4 Serial EEPROM: Address 0xA8

The serial **EEPROM** function allows EEPROM memory to be read and written. The data shown is the actual data that is written on the PIC MCU data EEPROM.

**FIGURE 1-5: SERIAL EEPROM**

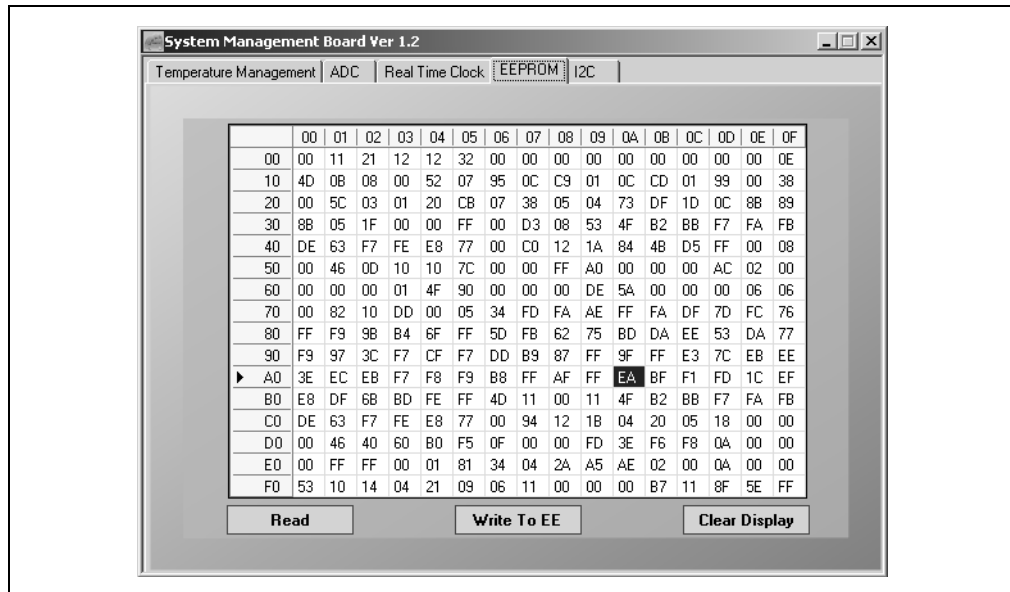

## 1.5.5 Thermal Management: Address 0xA6

The **Temperature Management** function provides control over fan controller settings. The fan speed output is based on upper and lower temperature set points and ambient temperature. See how adjusting these temperature set points and ambient temperature affect fan speed. In order to measure ambient temperature, JP202 must connect the middle pin to the pin labeled “MCP9700.” The JP202 jumper can also be moved to connect the POT pin to the middle pin. This can allow the sweeping of temperatures in the full range of temperature values.

**FIGURE 1-6: THERMAL MANAGEMENT**

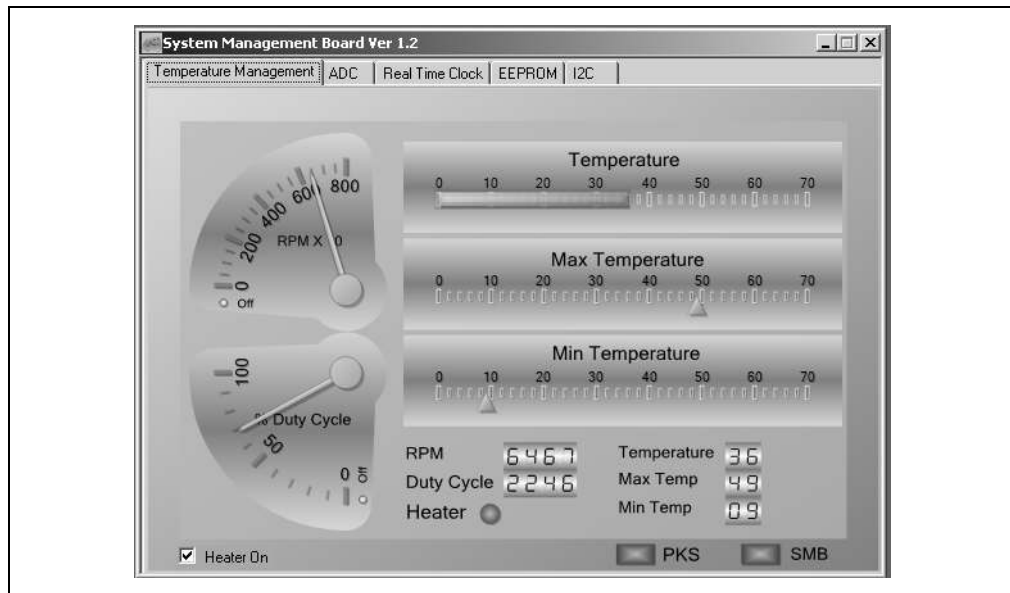



## 1.5.6 General I<sup>2</sup>C

The I<sup>2</sup>C function is an interface that allows master control of an I<sup>2</sup>C bus. Locate the Read section of the I<sup>2</sup>C Tab. A Read command can be executed by filling the “Slave Address [W]” field with the address of the device to be read. The “Word Address” field should be filled with the word address of the device to be read. Finally, the “Byte Count” field should be filled with the number of bytes to be read. The results of the command will be output on the screen to the left.

Locate the write section of the I<sup>2</sup>C Tab. A Write command is executed by filling the “Slave Address [W]” field with the address of the device to be written. The word address of the first byte to be written should be entered into the “Word Address” field. A single byte or multiple bytes of data can be filled in the data fields. The results will be shown on the screen to the left. See Appendix Table B-1 through Table B-4 for device address and word address details.

FIGURE 1-7: I<sup>2</sup>C™

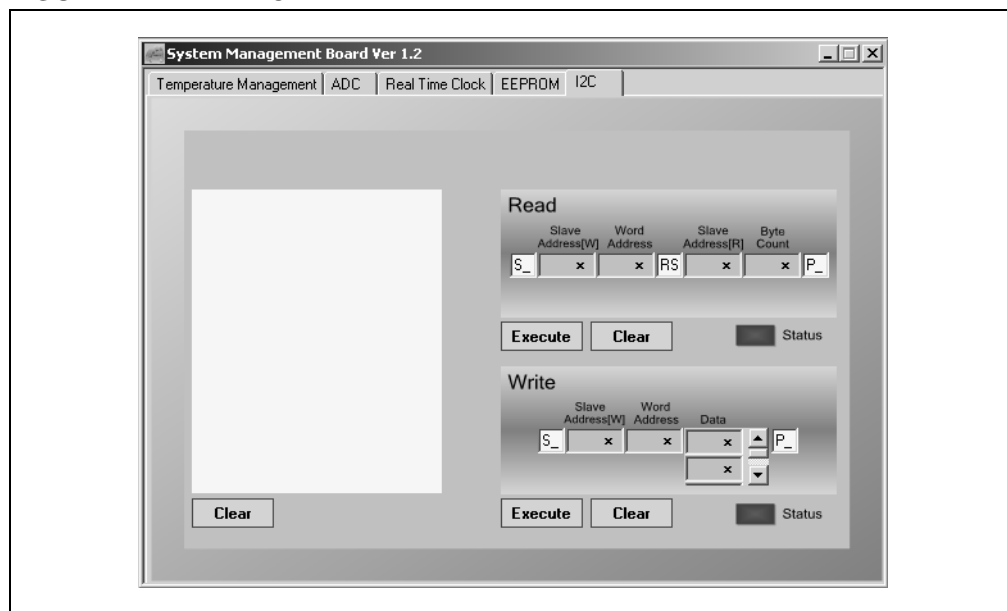

# PICDEM™ System Management User's Guide

---

---

NOTES:

---

---

## Chapter 2. Background

---

---

### 2.1 INTRODUCTION

This chapter provides background information on the System Management application and the PICDEM System Management Board. It also provides background information on the fan drive circuitry that is available on the board. Additional detailed information can be found in the PICDEM System Management presentation and source code included on the CD-ROM.

### 2.2 HIGHLIGHTS

Topics covered in this chapter include:

- PICDEM™ System Management Board and PICKit™ Serial Analyzer
- Fan Speed Control

### 2.3 PICDEM™ SYSTEM MANAGEMENT AND PICKIT™ SERIAL ANALYZER

The PICDEM™ System Management emulates four I<sup>2</sup>C peripherals usually found on a system management bus. The real-time clock, ADC, serial EEPROM and thermal management controller peripherals, typically reside on the I<sup>2</sup>C bus line of rack-mount servers and motherboards. The PIC16F886 integrates the functions of each device on the I<sup>2</sup>C communications bus, while responding to the specific address calls for each device.

The PICKit Serial Analyzer is a utility that allows control and monitoring of the I<sup>2</sup>C bus. It is able to generate the specific device calls and interpret data. This data can then be translated to a personal computer and can be interacted with through a graphical user interface. In the PICDEM™ System Management Board, the PICKit Serial Analyzer takes the place of the bus master that manages the devices on the I<sup>2</sup>C bus.

### 2.4 FAN SPEED CONTROL

#### 2.4.1 Two-wire Fan

Two-wire fans provide power and ground terminals. The fan can be controlled through low-speed (10-100 Hz) PWM.

**Note:** Be sure to verify with the fan manufacturer that the fan specifications allow for PWM control of input voltage.

As the duty cycle of the PWM signal increases, fan speed increases non-linearly. Fan speed feedback can be determined by measuring the time between commutation pulse noise that is generated on each revolution of the fan. Low-speed PWM can be generated by PIC microcontrollers using the Enhanced Capture/Compare/PWM module. Speed can be measured with comparator and timer peripherals.

## 2.4.2 Three-wire Fan

FIGURE 2-1: THREE-WIRE

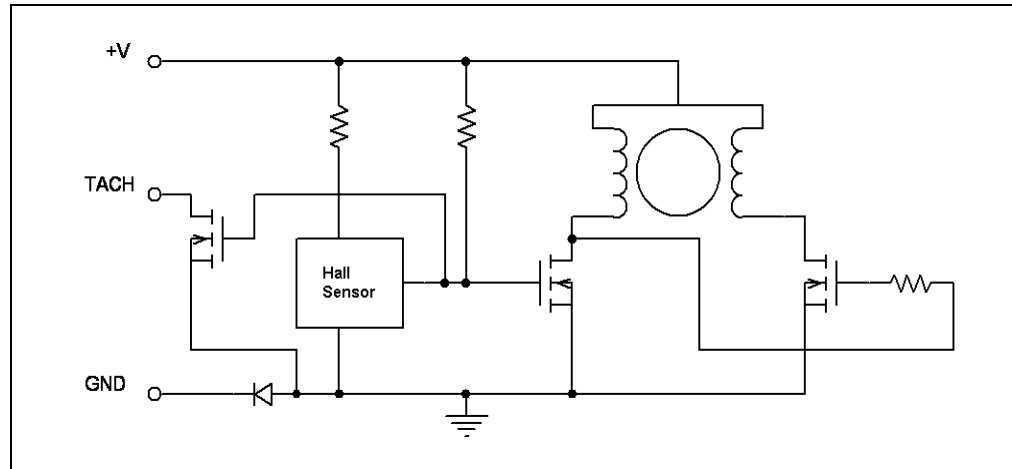

Three-wire fans provide a power, ground and tachometer terminals. The tachometer signal is typically generated by an internal Hall sensor that monitors magnetic field switching due to rotation in the permanent magnet of the fan. These fans can also be controlled through low-speed (10-100 Hz) PWM control of power input.

**Note:** Be sure to verify with the fan manufacturer that the fan specifications allow for PWM control of input voltage.

As the duty cycle of the PWM signal increases, the fan speed will also increase non-linearly. Speed feedback is measured in the same way as the two-wire fan, but the tachometer output of the fan on the third wire provides a square wave through an open drain output.

## 2.4.3 Measuring the Speed of a Two and Three-wire Fan

It is important to note that when measuring speed on two and three-wire fans, some additional conditions must be taken into account. The tachometer measurements are only valid when fan power is on. Commutation noise is only measurable when power is on and the Hall sensor output in three-wire fan is only valid when power is on. When the PWM signal switches low, the Hall sensor output is no longer valid. Therefore, a technique called pulse stretching must be employed to ensure accurate measurements. Whenever a measurement is made, power must be provided to the fan for the duration of the measurement. (See figure below for more details.)

FIGURE 2-2: PULSE STRETCHING

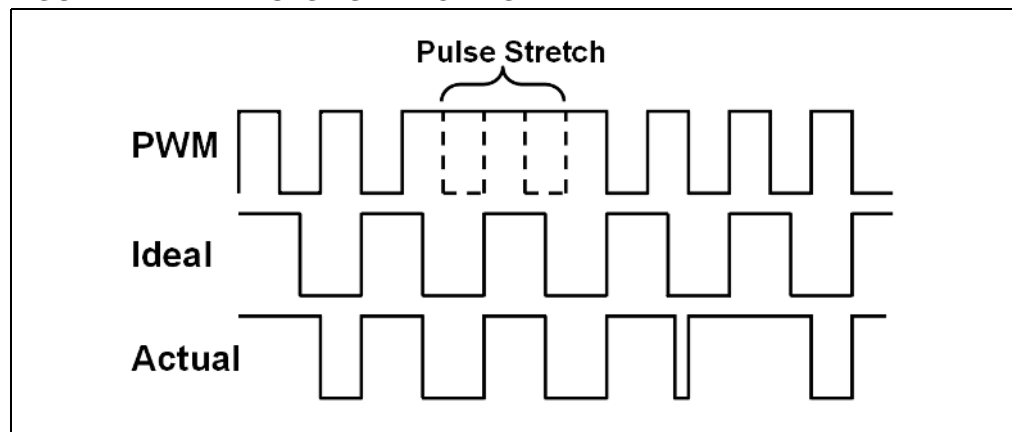

## 2.4.4 Four-wire Fan Control

Four-wire fan control provides a PWM input, tachometer output, fan power and ground. Instead of switching fan power, which must be done with two and three-wire fans, only the PWM input line is switched (typically at 10 kHz–30 kHz). As duty cycle of the fan increases, speed also increases non-linearly. The tachometer line is the same as the three-wire fan, generating pulses based on the rotation of the permanent magnet of the fan; however, the Hall sensor is always on. Therefore, PWM stretching is not needed to ensure an accurate measurement.

# PICDEM™ System Management User's Guide

---

---

NOTES:

---

---

## Chapter 3. Troubleshooting

---

---

### 3.1 INTRODUCTION

This chapter describes common problems and resolutions associated with using the PICDEM System Management Board.

### 3.2 COMMON PROBLEMS

#### 3.2.1 Serial Communications does not appear to be working

Reset the PICDEM System Management Board by pressing the SW100 switch labeled "MCLR."

The PICKit Serial Analyzer must be connected to header P104 labeled "PICKit Serial." Ensure that the board is being powered by a 12 VDC power supply.

#### 3.2.2 Microcontroller does not run after programming using the MPLAB<sup>®</sup> ICD 2

When using the MPLAB ICD 2 as a programmer, the microcontroller will not run unless you disconnect the MPLAB ICD 2 or release the MPLAB ICD 2 from Reset.

#### 3.2.3 The fan is not providing proper feedback

The 3-wire fan provides a tachometer output on the SENSE line. Ensure that the JP201 jumper connects to the center and "TACH" pins.

#### 3.2.4 Heating element is not heating

Check to see that the heater is enabled. The heater should be on if the CTRL line is high. If you are using the System Management GUI, ensure in the Temperature Management Tab that the checkbox "Heater On" is checked.

Check to ensure that the "Heater Enable" jumper JP200 is in place.

#### 3.2.5 Temperature is not changing

Check JP202 and ensure that it is connected to center pin and pin labeled MCP9700.

# PICDEM System Management<sup>®</sup> User's Guide

---

---

NOTES:



**Appendix A. Hardware Schematics**

**A.1 INTRODUCTION**

This appendix contains the PICDEM™ System Management Board hardware diagrams.

**FIGURE A-1: SCHEMATIC SHEET 1**

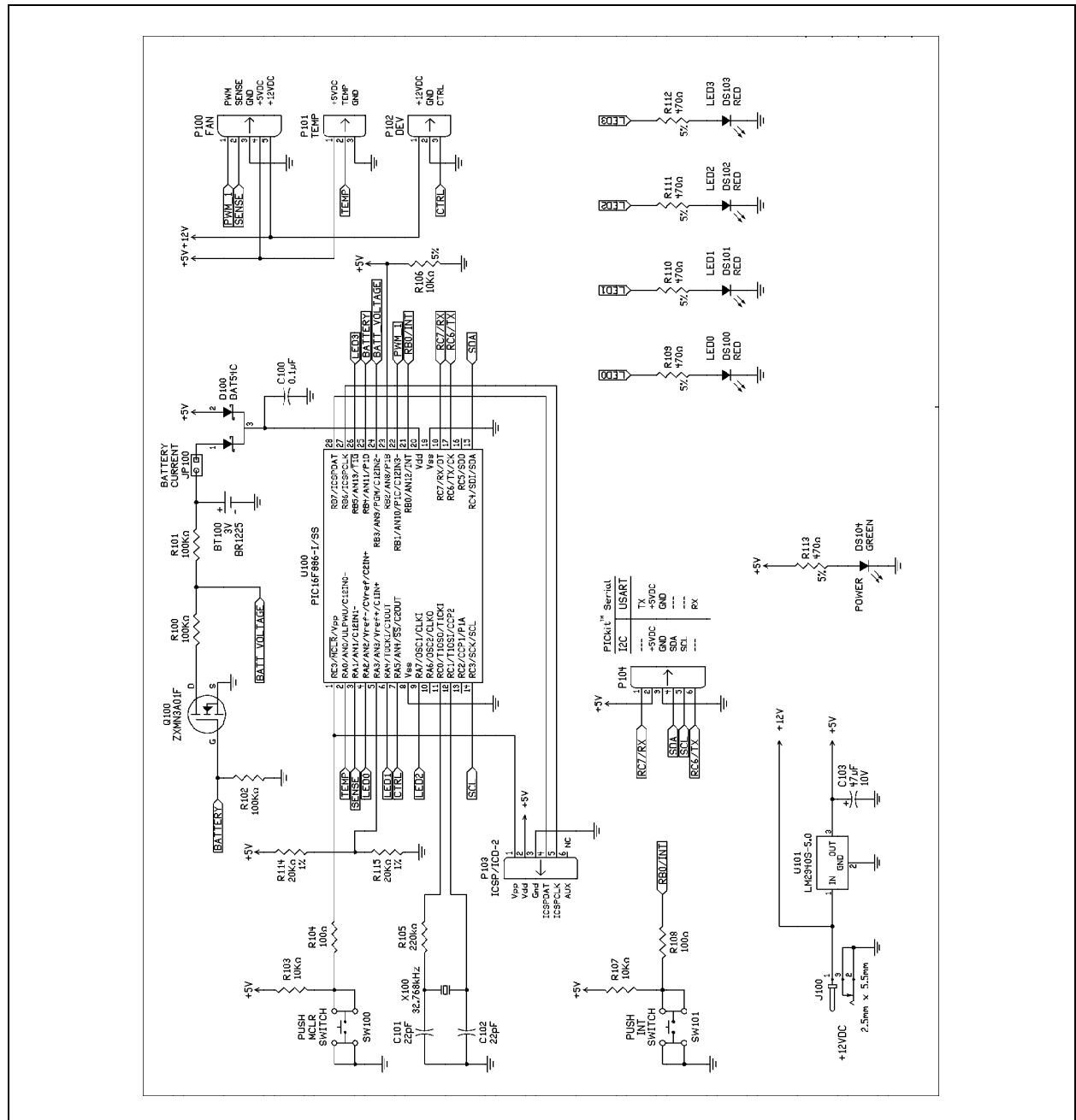

# PICDEM™ System Management User's Guide

FIGURE A-2: SCHEMATIC SHEET 2

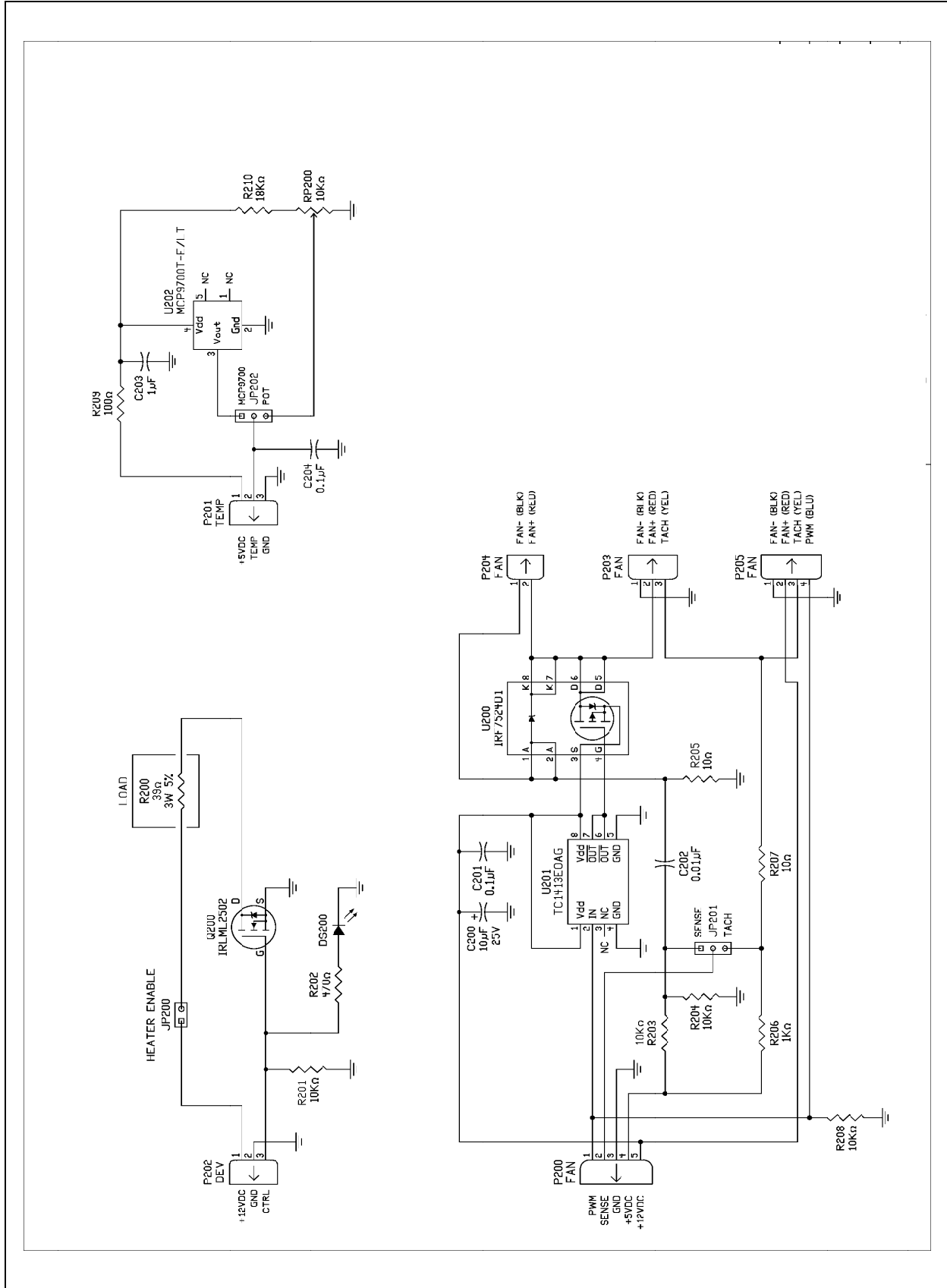

**Appendix B. Register Maps**

**B.1 INTRODUCTION**

This appendix contains the register maps for all of the emulated I<sup>2</sup>C devices.

**TABLE B-1: REAL-TIME CLOCK CALENDAR: 0XA2**

REG	NAME	DESCRIPTION
0x00	CONFIG 1	7: 0 6: 0 5: STOP – stop time function 0: RUN, 1: STOP) 4: 0 3: 0 2: 0 1: 0 0: 0
0x01	CONFIG 2	7: 0 6: 0 5: 0 4: 0 3: AF – Alarm flag 2: 0 1: AE – Alarm enable 0: 0
0x02	SECONDS	00-59 seconds, coding: BCD
0x03	MINUTES	00-59 minutes, coding: BCD
0x04	HOURS	00-23 hours, coding: BCD
0x05	WEEKDAYS	00-06 weekday
0x06	DAYS	01-31 day of the month
0x07	MONTHS	01-12 month of the year, coding: BCD
0x08	YEARS	00-99 year, coding: BCD
0x09	ALARM MIN	00-59 minute of alarm, coding: BCD bit 7: enable
0x0A	ALARM HOUR	00-23 hour of alarm, coding: BCD bit 7: enable
0x0B	ALARM DAY	01-31 day of alarm, coding BCD bit 7: enable
0x0C	ALARM WEEK	00-06 weekday of alarm bit 7: enable
0x0D	(not assigned)	
0x0E	(not assigned)	
0x0F	(not assigned)	

# PICDEM™ System Management User's Guide

**TABLE B-2: ANALOG-TO-DIGITAL CONVERTER: 0XA4**

REG	NAME	DESCRIPTION
0x00	ADC High Byte	B'0 0 0 0 9 8 7 6' Voltage (V) = [(ADC High Byte:ADC Low Byte/4) * 2.5 / 1023]
0x01	ADC Low Byte	B'5 4 3 2 1 0 x x' Voltage (V) = [(ADC High Byte:ADC Low Byte/4) * 2.5 / 1023]

**TABLE B-3: THERMAL CONTROLLER: 0XA6**

REG	NAME	DESCRIPTION
0x00	Temperature High Byte	Ambient Temperature (degC) = [(Temperature High Byte:Temperature Low Byte)/1023 * 2.5 - .50] / .010
0x01	Temperature Low Byte	
0x02	Duty Cycle High Byte	High Time of PWM High Time = (Duty Cycle High Byte:Duty Cycle Low Byte) / 32768 Duty Cycle = High Time / Period High:Period Low
0x03	Duty Cycle Low Byte	
0x04	Max. Output High Byte	Maximum Duty Cycle Output (PWM High Time) Max High Time = (Duty Cycle High Byte:Duty Cycle Low Byte) / 32768 Duty Cycle = Max High Time / Period High:Period Low
0x05	Max. Output Low Byte	
0x06	Min. Output High Byte	Minimum Duty Cycle Output (PWM High Time) Min High Time = (Duty Cycle High Byte:Duty Cycle Low Byte) / 32768 Duty Cycle = Min High Time / Period High:Period Low
0x07	Min. Output Low Byte	
0x08	Period High Byte	Duty Cycle Period Period = (Period High Byte: Period Low Byte) / 32768
0x09	Period Low Byte	
0x0A	Upper Temperature High Byte	Upper Temperature Set Point Upper Temperature (degC) = [((Upper Temperature High Byte:Upper Temperature Low Byte) / 1023)) - .50] / .010
0x0B	Upper Temperature Low Byte	
0x0C	Lower Temperature High Byte	Lower Temperature Set Point Lower Temperature (degC) = [((Lower Temperature High Byte:Lower Temperature Low Byte) / 1023)) - .50] / .010
0x0D	Lower Temperature Low Byte	
0x0E	Tach Speed High Byte	Tachometer Measurement Frequency = 32768 / Tach Speed High Byte: Tach Speed Low Byte RPM = (Frequency / 2) * 60
0x0F	Tach Speed Low Byte	
0x10	STATUS	Bit <7:1> = 0 Bit 0 = Heating Element Enable (0 = Off, 1 = On)

**TABLE B-4: SERIAL EEPROM: 0xA8**

<b>REG</b>	<b>NAME</b>	<b>DESCRIPTION</b>
0x00-0xFF	Data	EEPROM Data Byte

# PICDEM™ System Management User's Guide

---

---

NOTES:

# PICDEM™ System Management User's Guide

---

---

NOTES:



## WORLDWIDE SALES AND SERVICE

### AMERICAS

**Corporate Office**  
2355 West Chandler Blvd.  
Chandler, AZ 85224-6199  
Tel: 480-792-7200  
Fax: 480-792-7277  
Technical Support:  
<http://support.microchip.com>  
Web Address:  
[www.microchip.com](http://www.microchip.com)

**Atlanta**  
Duluth, GA  
Tel: 678-957-9614  
Fax: 678-957-1455

**Boston**  
Westborough, MA  
Tel: 774-760-0087  
Fax: 774-760-0088

**Chicago**  
Itasca, IL  
Tel: 630-285-0071  
Fax: 630-285-0075

**Dallas**  
Addison, TX  
Tel: 972-818-7423  
Fax: 972-818-2924

**Detroit**  
Farmington Hills, MI  
Tel: 248-538-2250  
Fax: 248-538-2260

**Kokomo**  
Kokomo, IN  
Tel: 765-864-8360  
Fax: 765-864-8387

**Los Angeles**  
Mission Viejo, CA  
Tel: 949-462-9523  
Fax: 949-462-9608

**Santa Clara**  
Santa Clara, CA  
Tel: 408-961-6444  
Fax: 408-961-6445

**Toronto**  
Mississauga, Ontario,  
Canada  
Tel: 905-673-0699  
Fax: 905-673-6509

### ASIA/PACIFIC

**Asia Pacific Office**  
Suites 3707-14, 37th Floor  
Tower 6, The Gateway  
Harbour City, Kowloon  
Hong Kong  
Tel: 852-2401-1200  
Fax: 852-2401-3431

**Australia - Sydney**  
Tel: 61-2-9868-6733  
Fax: 61-2-9868-6755

**China - Beijing**  
Tel: 86-10-8528-2100  
Fax: 86-10-8528-2104

**China - Chengdu**  
Tel: 86-28-8665-5511  
Fax: 86-28-8665-7889

**China - Fuzhou**  
Tel: 86-591-8750-3506  
Fax: 86-591-8750-3521

**China - Hong Kong SAR**  
Tel: 852-2401-1200  
Fax: 852-2401-3431

**China - Qingdao**  
Tel: 86-532-8502-7355  
Fax: 86-532-8502-7205

**China - Shanghai**  
Tel: 86-21-5407-5533  
Fax: 86-21-5407-5066

**China - Shenyang**  
Tel: 86-24-2334-2829  
Fax: 86-24-2334-2393

**China - Shenzhen**  
Tel: 86-755-8203-2660  
Fax: 86-755-8203-1760

**China - Shunde**  
Tel: 86-757-2839-5507  
Fax: 86-757-2839-5571

**China - Wuhan**  
Tel: 86-27-5980-5300  
Fax: 86-27-5980-5118

**China - Xian**  
Tel: 86-29-8833-7250  
Fax: 86-29-8833-7256

### ASIA/PACIFIC

**India - Bangalore**  
Tel: 91-80-4182-8400  
Fax: 91-80-4182-8422

**India - New Delhi**  
Tel: 91-11-4160-8631  
Fax: 91-11-4160-8632

**India - Pune**  
Tel: 91-20-2566-1512  
Fax: 91-20-2566-1513

**Japan - Yokohama**  
Tel: 81-45-471-6166  
Fax: 81-45-471-6122

**Korea - Gumi**  
Tel: 82-54-473-4301  
Fax: 82-54-473-4302

**Korea - Seoul**  
Tel: 82-2-554-7200  
Fax: 82-2-558-5932 or  
82-2-558-5934

**Malaysia - Penang**  
Tel: 60-4-646-8870  
Fax: 60-4-646-5086

**Philippines - Manila**  
Tel: 63-2-634-9065  
Fax: 63-2-634-9069

**Singapore**  
Tel: 65-6334-8870  
Fax: 65-6334-8850

**Taiwan - Hsin Chu**  
Tel: 886-3-572-9526  
Fax: 886-3-572-6459

**Taiwan - Kaohsiung**  
Tel: 886-7-536-4818  
Fax: 886-7-536-4803

**Taiwan - Taipei**  
Tel: 886-2-2500-6610  
Fax: 886-2-2508-0102

**Thailand - Bangkok**  
Tel: 66-2-694-1351  
Fax: 66-2-694-1350

### EUROPE

**Austria - Wels**  
Tel: 43-7242-2244-39  
Fax: 43-7242-2244-393

**Denmark - Copenhagen**  
Tel: 45-4450-2828  
Fax: 45-4485-2829

**France - Paris**  
Tel: 33-1-69-53-63-20  
Fax: 33-1-69-30-90-79

**Germany - Munich**  
Tel: 49-89-627-144-0  
Fax: 49-89-627-144-44

**Italy - Milan**  
Tel: 39-0331-742611  
Fax: 39-0331-466781

**Netherlands - Drunen**  
Tel: 31-416-690399  
Fax: 31-416-690340

**Spain - Madrid**  
Tel: 34-91-708-08-90  
Fax: 34-91-708-08-91

**UK - Wokingham**  
Tel: 44-118-921-5869  
Fax: 44-118-921-5820