

7/8" (22.2 mm) Conductive Plastic Potentiometer, Bushing Mount Type



FEATURES

- 7/8" diameter single turn
- Compact size, advanced design technology
- Offer a cost effective solution to your potentiometer requirements
- Suitable model for all industrial applications
- Material categorization: for definitions of compliance please see www.vishay.com/doc?99912

**RoHS
COMPLIANT**

QUICK REFERENCE DATA

Sensor type	ROTATIONAL, conductive plastic
Output type	Output by turrets
Market appliance	Industrial
Dimensions	7/8" (22.2 mm)

ELECTRICAL SPECIFICATIONS

PARAMETER		
Resistance	Standard range, 1 k Ω to 50 k Ω	
Tolerance	STANDARD $\pm 20\%$	SPECIAL TO $\pm 10\%$
Linearity (independent)	STANDARD $\pm 2.0\%$	SPECIAL $\pm 1.0\%$
Output smoothness	0.1 % maximum	
TCR	± 600 ppm/ $^{\circ}$ C maximum	
Power rating	1.0 W at 70 $^{\circ}$ C derated to 0 W at 125 $^{\circ}$ C	
Electrical travel	340 $^{\circ}$ \pm 3 $^{\circ}$	
End voltage	0.5 % maximum	
Dielectric withstanding voltage	1000 V _{RMS} , 60 Hz	
Insulation resistance	1000 M Ω , 500 V _{DC}	

MECHANICAL SPECIFICATIONS

PARAMETER		
Rotation	360 $^{\circ}$ continuous (optional mechanical stops 340 $^{\circ}$ \pm 3 $^{\circ}$)	
Mounting	3/8 - 32 UNEF - 2A	
Operating torque maximum	Starting and running 3.68 mNm (0.5 oz. - in)	
Shaft tolerance maximum		
Runout	0.13 mm (0.005")	
End play	0.25 mm (0.010")	
Radial play	0.13 mm (0.005")	
Weight	17.5 g (0.62 oz.)	

ORDERING INFORMATION

3	5	7	B	1	2	0	3	K	X	B	2	5	1	P	2	2
MODEL	STYLE	MECHANICAL FEATURES			OHMIC VALUE			TOLERANCE		LINEARITY	PACKAGING		SPECIAL REQUEST			
357	B = bushing	0 = non turn pin and continuous rotation 1 = no non turn pin and continuous rotation 2 = non turn pin with stops on rotation 3 = no non turn pin with stops on rotation			470 = 47 Ω 222 = 2.200 Ω 103 = 10 kΩ For ohmic value range see electrical specification			M = ± 20 % K = ± 10 %		X = 2 % A = 1 %	B25 = box 50 pcs. Special B10 = box 10 pcs. B05 = box 5 pcs.		Custom reference or shaft diameter 0 = 6.0 mm 1 = 6.35 mm 9 = special shaft type P = plain S = slotted FMF (from mounting face) range from 12 mm to 75 mm in 1 mm increments			

PART NUMBER DESCRIPTION (for information only)

357	B	1	203	K	X	B025	1P22
MODEL	STYLE	MECHANICAL FEATURES	OHMIC VALUE	TOLERANCE	LINEARITY	PACKAGING	SPECIAL REQUEST

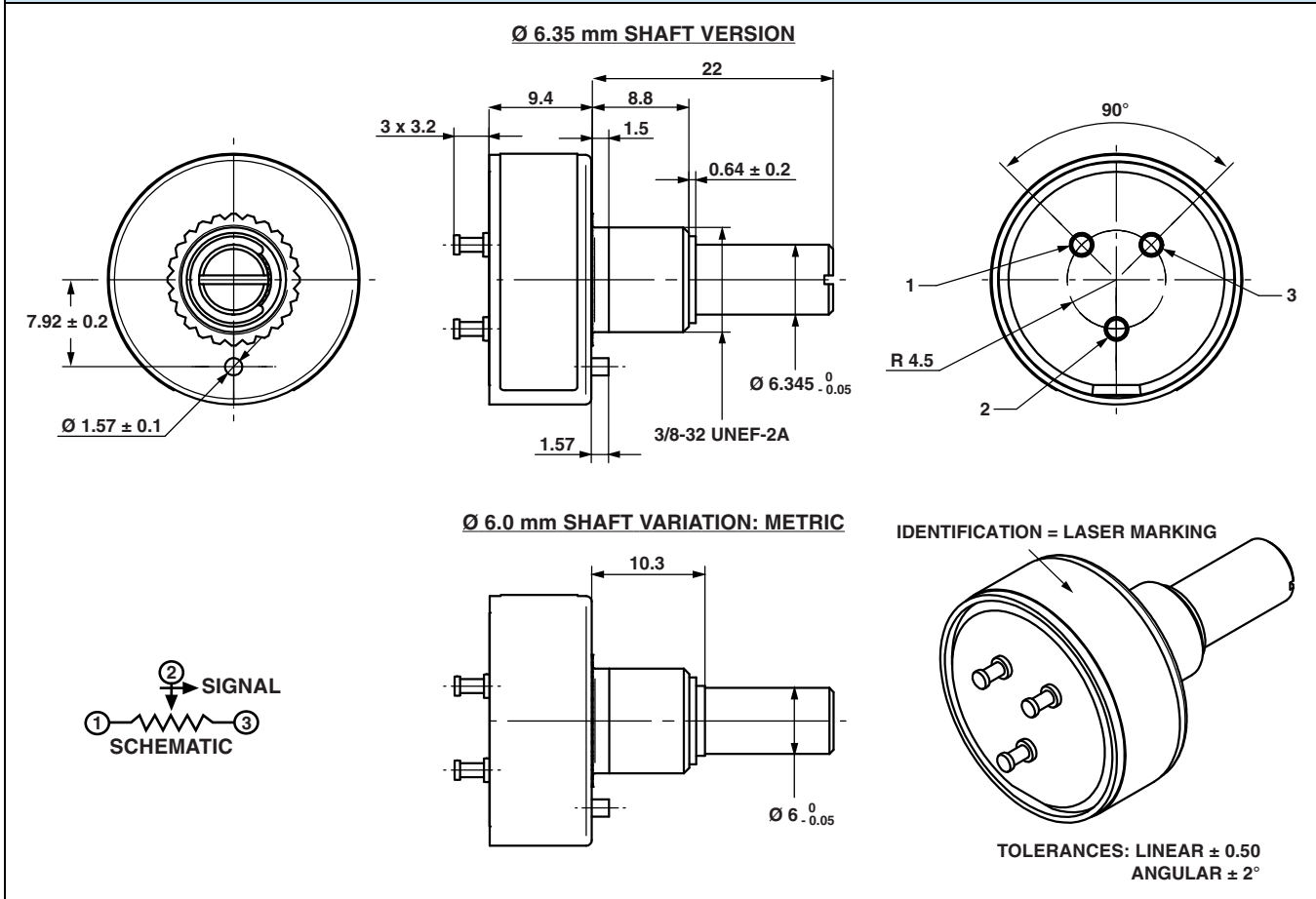
DIMENSIONS in inches (millimeters)



ENVIRONMENTAL SPECIFICATIONS	
Vibration	15 g, 10 Hz to 2000 Hz
Shock	50 g
Load Life	1000 h
Storage temperature range	-55 °C to +125 °C
Life	5 000 000 shaft revolutions
Materials	
Housing	Thermoplastic housing
Bushing	Brass, nickel plated
Rear lid	Alumina
Shaft	Stainless steel
Terminals	Turret type, solder plated
Bushing mount hardware	
Lockwasher internal tooth	Steel, nickel plated
Panel nut	Brass nickel plated

MARKING	
Unit Identification	<ul style="list-style-type: none"> • Complete part number Example: 357B0103MXB251S22 • Vishay logo • Date code • Terminal identification

RESISTANCE VALUE	
Ohms	1K, 2K, 5K, 10K, 20K, 50K

Note

- Nothing stated herein shall be construed as a guarantee of quality or durability



Disclaimer

ALL PRODUCT, PRODUCT SPECIFICATIONS AND DATA ARE SUBJECT TO CHANGE WITHOUT NOTICE TO IMPROVE RELIABILITY, FUNCTION OR DESIGN OR OTHERWISE.

Vishay Intertechnology, Inc., its affiliates, agents, and employees, and all persons acting on its or their behalf (collectively, "Vishay"), disclaim any and all liability for any errors, inaccuracies or incompleteness contained in any datasheet or in any other disclosure relating to any product.

Vishay makes no warranty, representation or guarantee regarding the suitability of the products for any particular purpose or the continuing production of any product. To the maximum extent permitted by applicable law, Vishay disclaims (i) any and all liability arising out of the application or use of any product, (ii) any and all liability, including without limitation special, consequential or incidental damages, and (iii) any and all implied warranties, including warranties of fitness for particular purpose, non-infringement and merchantability.

Statements regarding the suitability of products for certain types of applications are based on Vishay's knowledge of typical requirements that are often placed on Vishay products in generic applications. Such statements are not binding statements about the suitability of products for a particular application. It is the customer's responsibility to validate that a particular product with the properties described in the product specification is suitable for use in a particular application. Parameters provided in datasheets and / or specifications may vary in different applications and performance may vary over time. All operating parameters, including typical parameters, must be validated for each customer application by the customer's technical experts. Product specifications do not expand or otherwise modify Vishay's terms and conditions of purchase, including but not limited to the warranty expressed therein.

Hyperlinks included in this datasheet may direct users to third-party websites. These links are provided as a convenience and for informational purposes only. Inclusion of these hyperlinks does not constitute an endorsement or an approval by Vishay of any of the products, services or opinions of the corporation, organization or individual associated with the third-party website. Vishay disclaims any and all liability and bears no responsibility for the accuracy, legality or content of the third-party website or for that of subsequent links.

Except as expressly indicated in writing, Vishay products are not designed for use in medical, life-saving, or life-sustaining applications or for any other application in which the failure of the Vishay product could result in personal injury or death. Customers using or selling Vishay products not expressly indicated for use in such applications do so at their own risk. Please contact authorized Vishay personnel to obtain written terms and conditions regarding products designed for such applications.

No license, express or implied, by estoppel or otherwise, to any intellectual property rights is granted by this document or by any conduct of Vishay. Product names and markings noted herein may be trademarks of their respective owners.