

# PRODUCT SPECIFICATION DRAWING

**FINISH:**  
BODIES &  
HARDWARE:

PASSIVATED PER QQ-P-35C, TYPE II

CONTACTS:

GOLD OVER NICKEL

**PERFORMANCE:**

IMPEDANCE: 50 OHMS  
 VP: 70%  
 FREQ. RANGE: DC TO 18 GHz  
 DELAY: 115ps 17.9 GHz SPAN  
 VSWR: 1.25:1 (MAX) FOR DC-18 GHz  
 INSERTION LOSS: -.2db @ 18 GHz  
 OPERATING TEMP RANGE: -65 °C TO +155 °C

**MATERIAL:**

BODY &  
SHELL: STAINLESS STEEL PER AMS-5640, TYPE 303,  
COND.A

CONTACTS: BERYLLIUM COPPER PER ASTM B196,  
ALLOY UNS C17300

GASKET: SILICONE RUBBER, ZZ-R-765 DUROMETER 70

INSULATOR: PTFE PER ASTM-D1710

**MECHANICAL (TYP)**

CONNECTOR: MATES WITH MIL-STD-348

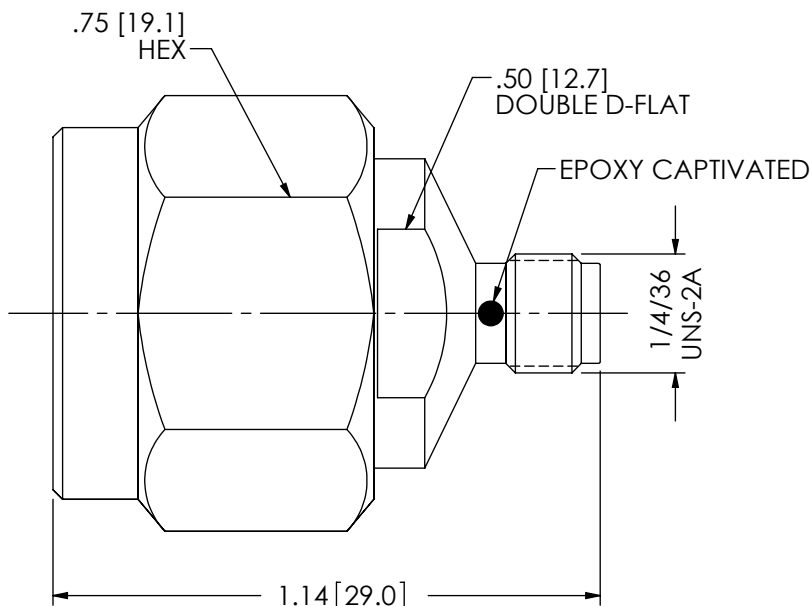

**RoHS COMPLIANT**

**PROPRIETARY**

THE INFORMATION HEREIN IS CONFIDENTIAL AND PROPRIETARY. NO DISCLOSURE, REPRODUCTION, OR FURTHER DISSEMINATION MAY BE MADE WITHOUT THE EXPRESSED WRITTEN CONSENT OF RF INDUSTRIES.

DIMENSIONS ARE IN INCHES  
TOLERANCES:

FRACTIONAL: ±1/64  
 ANGULAR: X° ±1'0"  
 X°X' ±15'  
 DECIMAL: .X ±.030  
 .XX ±.015  
 .XXX ±.005

INTERPRET DIMENSIONS AND TOLERANCES PER ASME Y14.5M - 1994

UNLESS OTHERWISE SPECIFIED

- 1) ALL DIMENSIONS ARE AFTER PLATING & HEAT TREATING.
- 2) BREAK CORNERS & EDGES .005 RADIUS MAX.
- 3) CHAMFER FIRST & LAST THREADS.
- 4) SURFACE ROUGHNESS 63 VI/A.W. MIL-STD-10.
- 5) DIAMETERS ON COMMON CENTERS TO BE CONCENTRIC WITHIN T.I.R.
- 6) REMOVE ALL BURRS

DRAWN BY: C. ZUNIGA 05/05/10

ENG APPROVAL: D. McREYNOLDS

MFG APPROVAL: --

QA APPROVAL: --

**RFP<sup>2</sup> RF PRECISION PRODUCTS**  
 A DIVISION OF RF INDUSTRIES  
 7610 MIRAMAR ROAD, SAN DIEGO, CA 92126-4202  
 (858) 549-6340 - FAX (858) 549-6345 - RFP2@RFINDUSTRIES.COM

TITLE: **N PLUG TO SMA JACK ADAPTER**

SIZE: **A** CODE: **000000** DWG. NO.: **P2RSA-3778**  
 SHEET 1 OF 1

REVISION HISTORY

REV	DESCRIPTION	DATE	APPROVED
-	ENGINEERING RELEASE	05/05/10	JDMc