

TC1270/TC1271

4-Pin Reset Monitors

Features:

- Precision V_{CC} Monitor for 1.8V, 2.7V, 3.0V, 3.3V and 5.0V Nominal Supplies
- Manual Reset Input
- 140 ms Minimum \overline{RESET} , Reset Output Duration
- \overline{RESET} Output Valid to $V_{CC} = 1.0V$ (TC1270)
- Low 7 μA Supply Current
- V_{CC} Transient Immunity
- Small 4-Pin SOT-143 Package
- No External Components
- Replacement for MAX811/812 and Offers a Lower Threshold Voltage Option

Applications:

- Computers
- Embedded Systems
- Battery Powered Equipment
- Critical μP Power Supply Monitoring

General Description

The TC1270 and TC1271 are cost-effective system supervisor circuits designed to monitor V_{CC} in digital systems and provide a reset signal to the host processor when necessary. A manual reset input is provided to override the reset monitor, and is suitable for use as a push button reset. No external components are required.

The reset output is driven active within 20 μs (4 μs for F version) of V_{CC} falling through the reset voltage threshold. Reset is maintained active for a minimum of 140 ms after V_{CC} rises above the reset threshold. The TC1271 has an active-high \overline{RESET} output while the TC1270 has an active-low \overline{RESET} output. The output of the TC1270 is valid down to $V_{CC} = 1V$. Both devices are available in a 4-Pin SOT-143 package.

The TC1270/TC1271 devices are optimized to reject fast transient glitches on the V_{CC} line. Low supply current of 7 μA ($V_{CC} = 3.3V$) makes these devices suitable for battery powered applications.

Typical Operating Circuit

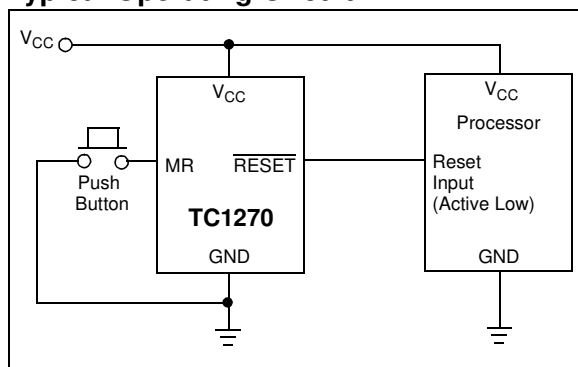

Package Type

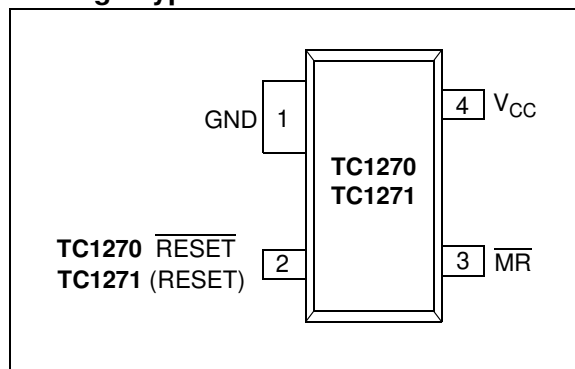

TC1270/TC1271

1.0 ELECTRICAL CHARACTERISTICS

Absolute Maximum Ratings†

Supply Voltage (V_{CC} to GND)	+6.0V
$\overline{\text{RESET}}$, Reset	-0.3V to ($V_{CC} + 0.3V$)
Input Current, V_{CC}	20 mA
Output Current, $\overline{\text{RESET}}$, Reset.....	20 mA
Operating Temperature Range.....	-40°C to +85°C
Storage Temperature Range	-65°C to +150°C

† Stresses above those listed under “Absolute Maximum Ratings” may cause permanent damage to the device. These are stress ratings only and functional operation of the device at these or any other conditions above those indicated in the operation sections of the specifications is not implied. Exposure to Absolute Maximum Rating conditions for extended periods may affect device reliability.

ELECTRICAL SPECIFICATIONS

Electrical Characteristics: $V_{CC} = 5V$ for L/M versions, $V_{CC} = 3.3V$ for T/S versions, $V_{CC} = 3V$ for R version, $V_{CC} = 2.0V$ for F version. Unless otherwise noted, $T_A = -40^\circ\text{C}$ to $+85^\circ\text{C}$. Typical values are at $T_A = +25^\circ\text{C}$. (Note 1).										
Symbol	Parameter	Min	Typ	Max	Units	Test Conditions				
V_{CC}	V_{CC} Range	1.2	—	5.5	V					
I_{CC}	Supply Current	—	7	15	μA	$V_{CC} > V_{TH}$, for L/M/R/S/T/F				
		—	10	15	μA	$V_{CC} < V_{TH}$, for L/M/R/S/T				
		—	6	12	μA	$V_{CC} < V_{TH}$, for F				
V_{TH}	Reset Threshold	4.54	4.63	4.72	V	TC127_L; $T_A = +25^\circ\text{C}$				
		4.50	—	4.75	V	$T_A = -40^\circ\text{C}$ to $+85^\circ\text{C}$				
		4.30	4.38	4.46	V	TC127_M; $T_A = +25^\circ\text{C}$				
		4.25	—	4.50	V	$T_A = -40^\circ\text{C}$ to $+85^\circ\text{C}$				
		3.03	3.08	3.14	V	TC127_T; $T_A = +25^\circ\text{C}$				
		3.00	—	3.15	V	$T_A = -40^\circ\text{C}$ to $+85^\circ\text{C}$				
	2.88	2.93	2.98	V	TC127_S; $T_A = +25^\circ\text{C}$	2.85	—	3.00	V	$T_A = -40^\circ\text{C}$ to $+85^\circ\text{C}$
	2.58	2.63	2.68	V	TC127_R; $T_A = +25^\circ\text{C}$	2.55	—	2.70	V	$T_A = -40^\circ\text{C}$ to $+85^\circ\text{C}$
1.71	1.75	1.79	V	TC127_F; $T_A = +25^\circ\text{C}$	1.70	—	1.80	V	$T_A = -40^\circ\text{C}$ to $+85^\circ\text{C}$	
	Reset Threshold Tempco	—	30	—	ppm/ $^\circ\text{C}$					
	V_{CC} to Reset Delay	—	20	—	μs	$V_{CC} = V_{TH}$ to $V_{TH} - 125\text{ mV}$; L/M/R/S/T/F				
		—	5	—						
t_{RP}	Reset Active Time-out Period	140	280	560	ms	$V_{CC} = V_{TH(\text{MAX})}$				
t_{MR}	$\overline{\text{MR}}$ Minimum Pulse Width	10	—	—	μs					
	$\overline{\text{MR}}$ Glitch Immunity	—	0.1	—	μs					
t_{MD}	$\overline{\text{MR}}$ to Reset Propagation Delay	—	0.5	—	μs					
V_{IH}	$\overline{\text{MR}}$ Input Threshold	2.3	—	—	V	$V_{CC} > V_{TH(\text{MAX})}$, TC127_L/M				
		$0.7 V_{CC}$	—	—	V	$V_{CC} > V_{TH(\text{MAX})}$, TC127_R/S/T/F				
V_{IL}		—	—	0.8	V	$V_{CC} > V_{TH(\text{MAX})}$, TC127_L/M				
		—	—	$0.15 V_{CC}$	V	$V_{CC} > V_{TH(\text{MAX})}$, TC127_R/S/T/F				
	$\overline{\text{MR}}$ Pull-up Resistance	10	20	40	$k\Omega$					
V_{OH}	Reset Output Voltage High (TC1271)	$0.8 V_{CC}$	—	—	V	$I_{\text{SOURCE}} = 150\ \mu\text{A}$; $V_{CC} \leq V_{TH(\text{MIN})}$				

Note 1: Production testing done at $T_A = +25^\circ\text{C}$, over temperature limits ensured by design.

Note 2: $\overline{\text{RESET}}$ output for TC1270, Reset output for TC1271.

ELECTRICAL SPECIFICATIONS (CONTINUED)

Electrical Characteristics: $V_{CC} = 5V$ for L/M versions, $V_{CC} = 3.3V$ for T/S versions, $V_{CC} = 3V$ for R version, $V_{CC} = 2.0V$ for F version. Unless otherwise noted, $T_A = -40^{\circ}C$ to $+85^{\circ}C$. Typical values are at $T_A = +25^{\circ}C$. (**Note 1**).

Symbol	Parameter	Min	Typ	Max	Units	Test Conditions
V_{OL}	Reset Output Voltage Low (TC1271)	—	—	0.2	V	TC1271F only, $I_{SINK} = 500 \mu A$, $V_{CC} = V_{TH(MAX)}$
		—	—	0.3	V	TC1271R/S/T only, $I_{SINK} = 1.2 \text{ mA}$, $V_{CC} = V_{TH(MAX)}$
		—	—	0.4	V	TC1271L/M only, $I_{SINK} = 3.2 \text{ mA}$, $V_{CC} = V_{TH(MAX)}$
V_{OL}	$\overline{\text{RESET}}$ Output Voltage Low (TC1270)	—	—	0.3	V	TC1270R/S/T only, $I_{SINK} = 1.2 \text{ mA}$, $V_{CC} = V_{TH(MIN)}$ TC1270F only: $I_{SINK} = 500 \mu A$, $V_{CC} = V_{TH(MIN)}$
		—	—	0.4	V	TC1270L/M only, $I_{SINK} = 3.2 \text{ mA}$, $V_{CC} = V_{TH(MIN)}$
		—	—	TBD	V	$I_{SINK} = 50 \mu A$, $V_{CC} > 1.0V$
V_{OH}	$\overline{\text{RESET}}$ Output Voltage High (TC1270)	$V_{CC} - 1.5$	—	—	V	TC1270L/M only, $I_{SOURCE} = 800 \mu A$, $V_{CC} = V_{TH(MAX)}$
		$0.8 V_{CC}$	—	—	V	TC1270R/S/T/F only, $I_{SOURCE} = 500 \mu A$, $V_{CC} = V_{TH(MAX)}$

Note 1: Production testing done at $T_A = +25^{\circ}C$, over temperature limits ensured by design.

2: $\overline{\text{RESET}}$ output for TC1270, Reset output for TC1271.

TC1270/TC1271

2.0 TYPICAL CHARACTERISTICS

Note: The graphs and tables provided following this note are a statistical summary based on a limited number of samples and are provided for informational purposes only. The performance characteristics listed herein are not tested or guaranteed. In some graphs or tables, the data presented may be outside the specified operating range (e.g., outside specified power supply range) and therefore outside the warranted range.

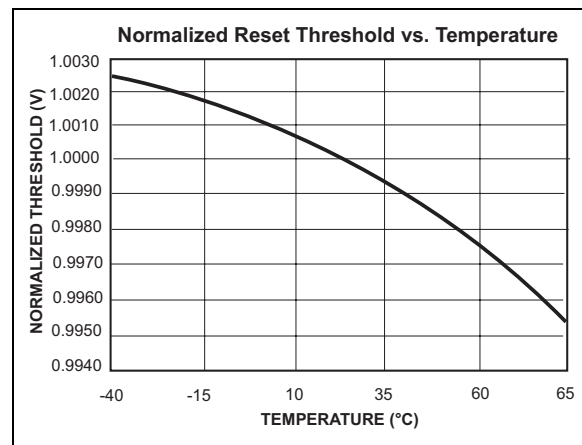
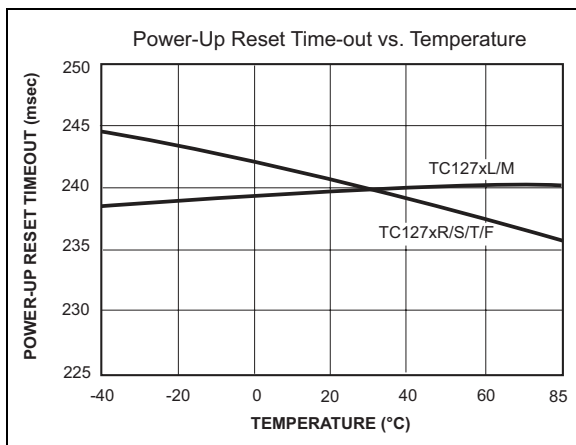
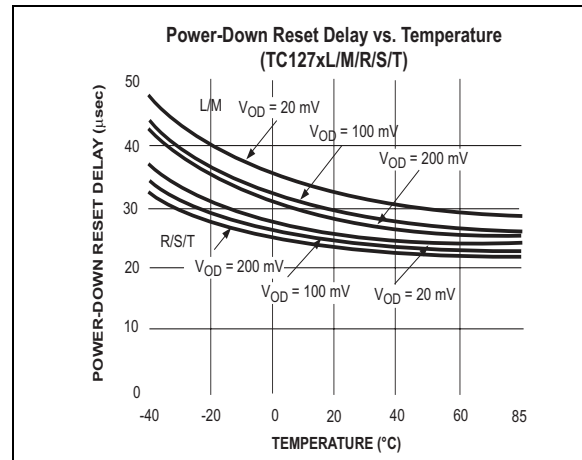
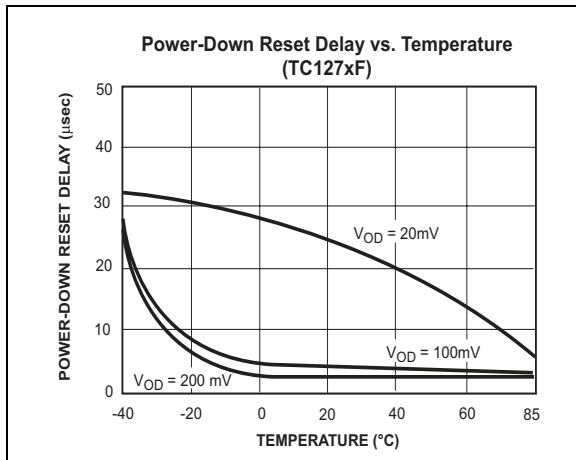
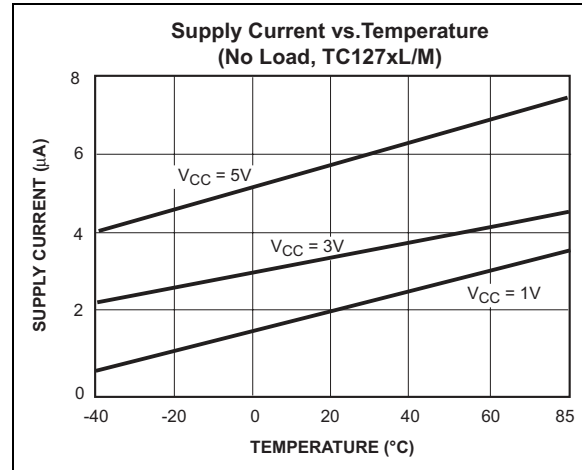
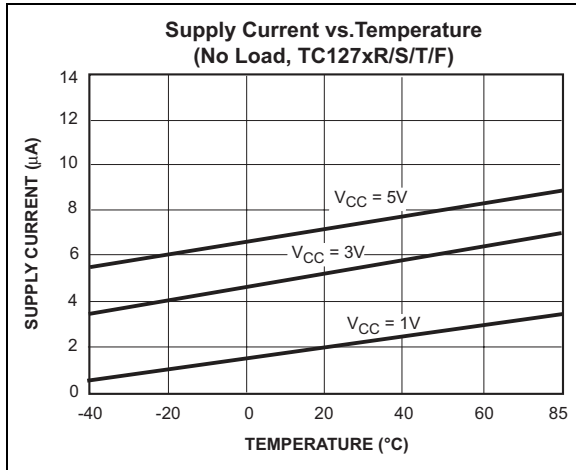

3.0 PIN DESCRIPTIONS

The descriptions of the pins are listed in [Table 3-1](#).

TABLE 3-1: PIN FUNCTION TABLE

Pin No.	Symbol	Description
1	GND	Ground
2	$\overline{\text{RESET}}$ (TC1270)	$\overline{\text{RESET}}$ output remains low while V_{CC} is below the Reset voltage threshold, and for at least 140 ms min. after V_{CC} rises above Reset threshold
2	RESET (TC1271)	Reset output remains high while V_{CC} is below the Reset voltage threshold, and for at least 140 ms min. after V_{CC} rises above Reset threshold
3	$\overline{\text{MR}}$	Manual Reset input generates a Reset when $\overline{\text{MR}}$ is below V_{IL}
4	V_{CC}	Supply voltage

3.1 Ground Terminal (GND)

GND provides the negative reference for the analog input voltage. Typically, the circuit ground is used.

3.2 Reset Output ($\overline{\text{RESET}}$) (TC1270)

$\overline{\text{RESET}}$ output remains low while V_{CC} is below the Reset voltage threshold (V_{TRIP}). Once the device voltage (V_{CC}) returns to a high level ($V_{TRIP} + V_{HYS}$), the device will remain in Reset for the Reset delay timer (T_{RST}). After that time expires, the $\overline{\text{RESET}}$ pin will be driven to the high state.

3.3 Reset Output (RESET) (TC1271)

RESET output remains high while V_{CC} is below the Reset voltage threshold (V_{TRIP}). Once the device voltage (V_{CC}) returns to a high level ($V_{TRIP} + V_{HYS}$), the device will remain in Reset for the Reset delay timer (T_{RST}). After that time expires, the RESET pin will be driven to the low state.

3.4 Manual Reset ($\overline{\text{MR}}$)

The Manual Reset ($\overline{\text{MR}}$) input pin allows a push button switch to easily be connected to the system. When the push button is depressed, it forces a system Reset. This pin has circuitry that filters noise that may be present on the MR signal.

The $\overline{\text{MR}}$ pin is active-low and has an internal pull-up resistor.

3.5 Supply Voltage (V_{CC})

V_{CC} can be used for power supply monitoring or a voltage level that requires monitoring.

TC1270/TC1271

4.0 APPLICATIONS INFORMATION

4.1 V_{CC} Transient Rejection

The TC1270/TC1271 provides accurate V_{CC} monitoring and Reset timing during power-up, power-down, and brownout/sag conditions, and rejects negative-going transients (glitches) on the power supply line. Figure 4-3 shows the maximum transient duration vs. maximum negative excursion (overdrive) for glitch rejection. Any combination of duration and overdrive that lays **under** the curve will **not** generate a Reset signal. Combinations above the curve are detected as a brown-out or power-down. Transient immunity can be improved by adding a capacitor in close proximity to the V_{CC} pin of the TC1270/TC1271.

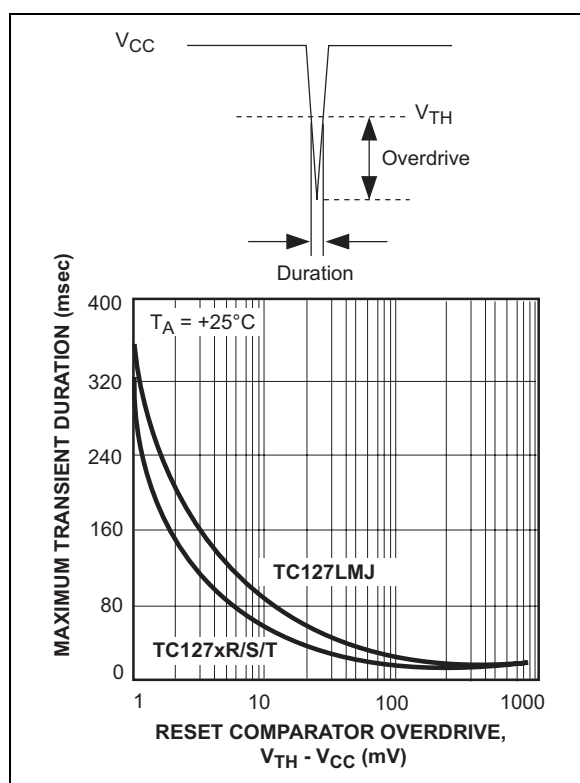

FIGURE 4-1: Maximum Transient Duration vs. Overdrive for Glitch Rejection at +25°C.

4.2 Reset Signal Integrity During Power-Down

The TC1270 $\overline{\text{RESET}}$ output is valid to $V_{CC} = 1.0V$. Below this voltage the output becomes an “open circuit” and does not sink current. This means CMOS logic inputs to the microprocessor will be floating at an undetermined voltage. Most digital systems are completely shut down well above this voltage. However, in situations where $\overline{\text{RESET}}$ must be maintained valid to $V_{CC} = 0V$, a pull-down resistor must

be connected from $\overline{\text{RESET}}$ to ground to discharge stray capacitances and hold the output low (Figure 4-2). This resistor value, though not critical, should be chosen such that it does not appreciably load $\overline{\text{RESET}}$ under normal operation (100 k Ω will be suitable for most applications). Similarly, a pull-up resistor to V_{CC} is required for the TC1271 to ensure a valid high $\overline{\text{RESET}}$ for V_{CC} below 1.1V.

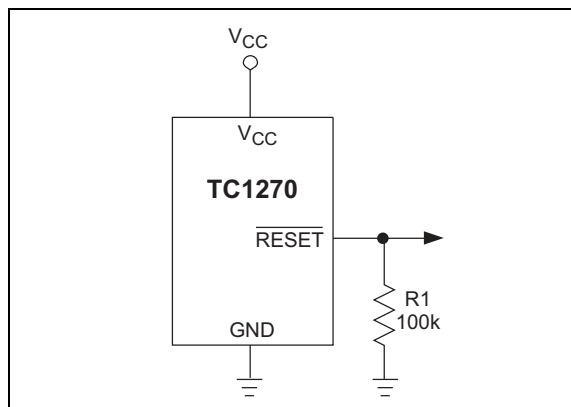

FIGURE 4-2: Ensuring $\overline{\text{RESET}}$ Valid to $V_{CC} = 0V$.

4.3 Processors With Bidirectional I/O Pins

Some microprocessors (such as Motorola’s 68HC11) have bidirectional Reset pins. Depending on the current drive capability of the processor pin, an indeterminate logic level may result if there is a logic conflict. This can be avoided by adding a 4.7 k Ω resistor in series with the output of the TC1270/TC1271 (Figure 4-3). If there are other components in the system which require a Reset signal, they should be buffered so as not to load the Reset line. If the other components are required to follow the Reset I/O of the microprocessor, the buffer should be connected as shown with the solid line.

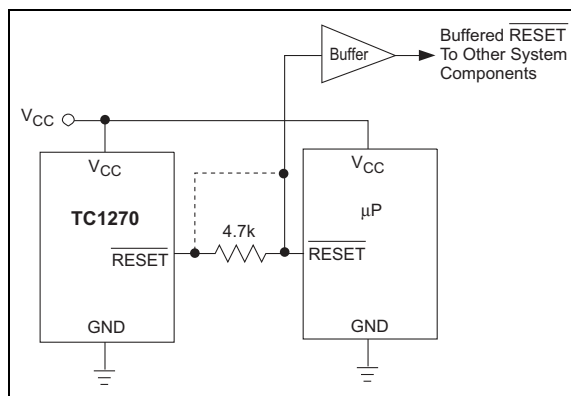
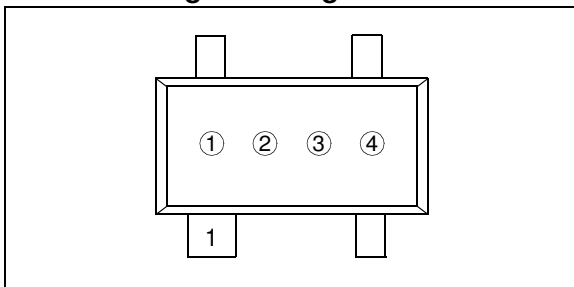

FIGURE 4-3: Interfacing to Bidirectional Reset I/O.

5.0 PACKAGING INFORMATION

5.1 Package Marking Information



① & ② = part number code + threshold voltage (two-digit code)

Part Number	(V)	TC1270 Code
TC1270LERCTR	4.63	S1
TC1270MERCTR	4.38	S2
TC1270TERCTR	3.08	S3
TC1270SERCTR	2.93	S4
TC1270RERCTR	2.63	S5
TC1270FERCTR	1.75	S7
Part Number	(V)	TC1271 Code
TC1271LERCTR	4.63	T1
TC1271MERCTR	4.38	T2
TC1271TERCTR	3.08	T3
TC1271SERCTR	2.9	T4
TC1271RERCTR	2.63	T5
TC1271FERCTR	1.75	T7

③ represents year and quarter code

④ represents production lot ID code

5.2 Taping Form

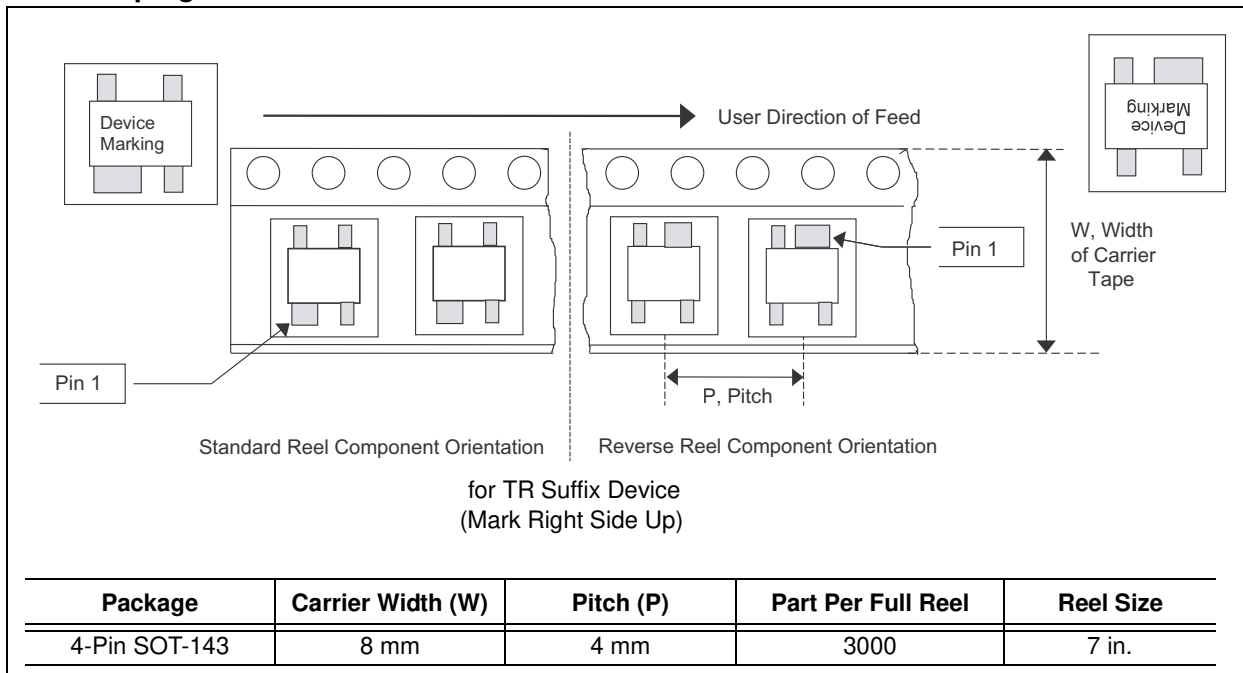

TC1270/TC1271

4-Lead Plastic Small Outline Transistor (RC) [SOT-143]

Note: For the most current package drawings, please see the Microchip Packaging Specification located at <http://www.microchip.com/packaging>

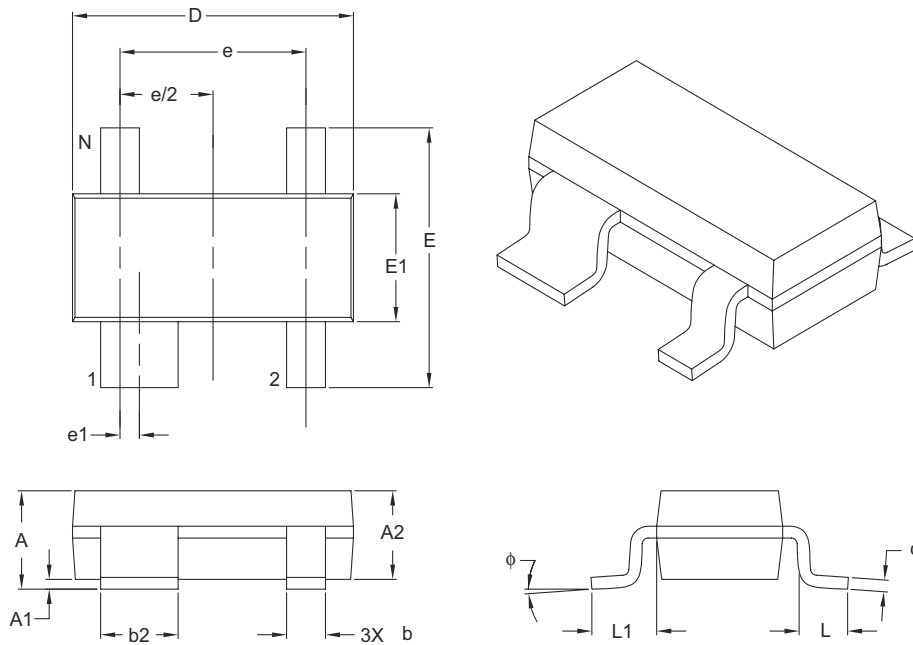

Dimension Limits	Units	MILLIMETERS		
		MIN	NOM	MAX
Number of Pins	N	4		
Pitch	e	1.92 BSC		
Pin1 Offset	e1	0.20 BSC		
Overall Height	A	0.80	–	1.22
Molded Package Thickness	A2	0.75	0.90	1.07
Standoff §	A1	0.01	–	0.15
Overall Width	E	2.10	–	2.64
Molded Package Width	E1	1.20	1.30	1.40
Overall Length	D	2.67	2.90	3.05
Foot Length	L	0.13	0.50	0.60
Footprint	L1	0.54 REF		
Foot Angle	φ	0°	–	8°
Lead Thickness	c	0.08	–	0.20
Lead 1 Width	b1	0.76	–	0.94
Leads 2, 3 & 4 Width	b	0.30	–	0.54

Notes:

- § Significant Characteristic.
- Dimensions D and E1 do not include mold flash or protrusions. Mold flash or protrusions shall not exceed 0.25 mm per side.
- Dimensioning and tolerancing per ASME Y14.5M.
 - BSC: Basic Dimension. Theoretically exact value shown without tolerances.
 - REF: Reference Dimension, usually without tolerance, for information purposes only.

Microchip Technology Drawing C04-031B

APPENDIX A: REVISION HISTORY

Revision D (February 2007)

- **Section 5.0 “Packaging Information”:**
Corrected SOT-143 Packaging Information.
- **Section 3.0 “Pin Descriptions”:** Added pin descriptions.
- Added disclaimer on package outline drawing.
- Updated package outline drawing.
- **Section 1.0 “Electrical Characteristics”:** Reformatted table.

Revision C (June 2006)

- Enhanced SOT-143 Packaging Information.

Revision B (May 2002)

- Undocumented changes.

Revision A (March 2002)

- Original Release of this Document.

TC1270/TC1271

NOTES:

PRODUCT IDENTIFICATION SYSTEM

To order or obtain information, e.g., on pricing or delivery, refer to the factory or the listed sales office.

<u>PART NO.</u>	X	X	XX	
Device	Threshold Voltage	Temperature Range	Package	
Device TC1270: 4-Pin <u>RESET</u> Monitor TC1271: 4-Pin <u>RESET</u> Monitor				Examples: a) TC1270LERCTR: 4.63V b) TC1270MERCTR: 4.38V c) TC1270TERCTR: 3.08V d) TC1270SERCPBTR: 2.93V e) TC1270SERCTR: 2.93V f) TC1270RERCTR: 2.63V g) TC1270FERCTR: 1.75V a) TC1271LERCTR: 4.63V b) TC1271MERCTR: 4.38V c) TC1271TERCTR: 3.08V d) TC1271SERCTR: 2.93V e) TC1271RERCTR: 2.63V f) TC1271FERCTR: 1.75V
Threshold voltage (typical)	L = 4.63 M = 4.38 T = 3.08 S = 2.93 R = 2.63 F = 1.75			
Temperature Range	E = -40°C to +85°C			
Package	RCTR = Plastic small outline transistor (RC) SOT-143, 4 lead, (tape and reel).			

TC1270/TC1271

NOTES:

Note the following details of the code protection feature on Microchip devices:

- Microchip products meet the specification contained in their particular Microchip Data Sheet.
- Microchip believes that its family of products is one of the most secure families of its kind on the market today, when used in the intended manner and under normal conditions.
- There are dishonest and possibly illegal methods used to breach the code protection feature. All of these methods, to our knowledge, require using the Microchip products in a manner outside the operating specifications contained in Microchip's Data Sheets. Most likely, the person doing so is engaged in theft of intellectual property.
- Microchip is willing to work with the customer who is concerned about the integrity of their code.
- Neither Microchip nor any other semiconductor manufacturer can guarantee the security of their code. Code protection does not mean that we are guaranteeing the product as “unbreakable.”

Code protection is constantly evolving. We at Microchip are committed to continuously improving the code protection features of our products. Attempts to break Microchip's code protection feature may be a violation of the Digital Millennium Copyright Act. If such acts allow unauthorized access to your software or other copyrighted work, you may have a right to sue for relief under that Act.

Information contained in this publication regarding device applications and the like is provided only for your convenience and may be superseded by updates. It is your responsibility to ensure that your application meets with your specifications. MICROCHIP MAKES NO REPRESENTATIONS OR WARRANTIES OF ANY KIND WHETHER EXPRESS OR IMPLIED, WRITTEN OR ORAL, STATUTORY OR OTHERWISE, RELATED TO THE INFORMATION, INCLUDING BUT NOT LIMITED TO ITS CONDITION, QUALITY, PERFORMANCE, MERCHANTABILITY OR FITNESS FOR PURPOSE. Microchip disclaims all liability arising from this information and its use. Use of Microchip devices in life support and/or safety applications is entirely at the buyer's risk, and the buyer agrees to defend, indemnify and hold harmless Microchip from any and all damages, claims, suits, or expenses resulting from such use. No licenses are conveyed, implicitly or otherwise, under any Microchip intellectual property rights.

Trademarks

The Microchip name and logo, the Microchip logo, Accuron, dsPIC, KEELOQ, KEELOQ logo, microID, MPLAB, PIC, PICmicro, PICSTART, PRO MATE, PowerSmart, rfPIC, and SmartShunt are registered trademarks of Microchip Technology Incorporated in the U.S.A. and other countries.

AmpLab, FilterLab, Linear Active Thermistor, Migratable Memory, MXDEV, MXLAB, PS logo, SEEVAL, SmartSensor and The Embedded Control Solutions Company are registered trademarks of Microchip Technology Incorporated in the U.S.A.

Analog-for-the-Digital Age, Application Maestro, CodeGuard, dsPICDEM, dsPICDEM.net, dsPICworks, ECAN, ECONOMONITOR, FanSense, FlexROM, fuzzzyLAB, In-Circuit Serial Programming, ICSP, ICEPIC, Mindi, MiWi, MPASM, MPLAB Certified logo, MPLIB, MPLINK, PICkit, PICDEM, PICDEM.net, PICLAB, PICtail, PowerCal, PowerInfo, PowerMate, PowerTool, REAL ICE, rfLAB, rfPICDEM, Select Mode, Smart Serial, SmartTel, Total Endurance, UNI/O, WiperLock and ZENA are trademarks of Microchip Technology Incorporated in the U.S.A. and other countries.

SQTP is a service mark of Microchip Technology Incorporated in the U.S.A.

All other trademarks mentioned herein are property of their respective companies.

© 2007, Microchip Technology Incorporated, Printed in the U.S.A., All Rights Reserved.

 Printed on recycled paper.

QUALITY MANAGEMENT SYSTEM
CERTIFIED BY DNV
== ISO/TS 16949:2002 ==

Microchip received ISO/TS-16949:2002 certification for its worldwide headquarters, design and wafer fabrication facilities in Chandler and Tempe, Arizona, Gresham, Oregon and Mountain View, California. The Company's quality system processes and procedures are for its PIC[®] MCUs and dsPIC[®] DSCs, KEELOQ[®] code hopping devices, Serial EEPROMs, microperipherals, nonvolatile memory and analog products. In addition, Microchip's quality system for the design and manufacture of development systems is ISO 9001:2000 certified.



WORLDWIDE SALES AND SERVICE

AMERICAS

Corporate Office
2355 West Chandler Blvd.
Chandler, AZ 85224-6199
Tel: 480-792-7200
Fax: 480-792-7277
Technical Support:
<http://support.microchip.com>
Web Address:
www.microchip.com

Atlanta

Duluth, GA
Tel: 678-957-9614
Fax: 678-957-1455

Boston

Westborough, MA
Tel: 774-760-0087
Fax: 774-760-0088

Chicago

Itasca, IL
Tel: 630-285-0071
Fax: 630-285-0075

Dallas

Addison, TX
Tel: 972-818-7423
Fax: 972-818-2924

Detroit

Farmington Hills, MI
Tel: 248-538-2250
Fax: 248-538-2260

Kokomo

Kokomo, IN
Tel: 765-864-8360
Fax: 765-864-8387

Los Angeles

Mission Viejo, CA
Tel: 949-462-9523
Fax: 949-462-9608

Santa Clara

Santa Clara, CA
Tel: 408-961-6444
Fax: 408-961-6445

Toronto

Mississauga, Ontario,
Canada
Tel: 905-673-0699
Fax: 905-673-6509

ASIA/PACIFIC

Asia Pacific Office
Suites 3707-14, 37th Floor
Tower 6, The Gateway
Harbour City, Kowloon
Hong Kong
Tel: 852-2401-1200
Fax: 852-2401-3431

Australia - Sydney
Tel: 61-2-9868-6733
Fax: 61-2-9868-6755

China - Beijing
Tel: 86-10-8528-2100
Fax: 86-10-8528-2104

China - Chengdu
Tel: 86-28-8665-5511
Fax: 86-28-8665-7889

China - Fuzhou
Tel: 86-591-8750-3506
Fax: 86-591-8750-3521

China - Hong Kong SAR
Tel: 852-2401-1200
Fax: 852-2401-3431

China - Qingdao
Tel: 86-532-8502-7355
Fax: 86-532-8502-7205

China - Shanghai
Tel: 86-21-5407-5533
Fax: 86-21-5407-5066

China - Shenyang
Tel: 86-24-2334-2829
Fax: 86-24-2334-2393

China - Shenzhen
Tel: 86-755-8203-2660
Fax: 86-755-8203-1760

China - Shunde
Tel: 86-757-2839-5507
Fax: 86-757-2839-5571

China - Wuhan
Tel: 86-27-5980-5300
Fax: 86-27-5980-5118

China - Xian
Tel: 86-29-8833-7250
Fax: 86-29-8833-7256

ASIA/PACIFIC

India - Bangalore
Tel: 91-80-4182-8400
Fax: 91-80-4182-8422

India - New Delhi
Tel: 91-11-4160-8631
Fax: 91-11-4160-8632

India - Pune
Tel: 91-20-2566-1512
Fax: 91-20-2566-1513

Japan - Yokohama
Tel: 81-45-471- 6166
Fax: 81-45-471-6122

Korea - Gumi
Tel: 82-54-473-4301
Fax: 82-54-473-4302

Korea - Seoul
Tel: 82-2-554-7200
Fax: 82-2-558-5932 or
82-2-558-5934

Malaysia - Penang
Tel: 60-4-646-8870
Fax: 60-4-646-5086

Philippines - Manila
Tel: 63-2-634-9065
Fax: 63-2-634-9069

Singapore
Tel: 65-6334-8870
Fax: 65-6334-8850

Taiwan - Hsin Chu
Tel: 886-3-572-9526
Fax: 886-3-572-6459

Taiwan - Kaohsiung
Tel: 886-7-536-4818
Fax: 886-7-536-4803

Taiwan - Taipei
Tel: 886-2-2500-6610
Fax: 886-2-2508-0102

Thailand - Bangkok
Tel: 66-2-694-1351
Fax: 66-2-694-1350

EUROPE

Austria - Wels
Tel: 43-7242-2244-39
Fax: 43-7242-2244-393

Denmark - Copenhagen
Tel: 45-4450-2828
Fax: 45-4485-2829

France - Paris
Tel: 33-1-69-53-63-20
Fax: 33-1-69-30-90-79

Germany - Munich
Tel: 49-89-627-144-0
Fax: 49-89-627-144-44

Italy - Milan
Tel: 39-0331-742611
Fax: 39-0331-466781

Netherlands - Drunen
Tel: 31-416-690399
Fax: 31-416-690340

Spain - Madrid
Tel: 34-91-708-08-90
Fax: 34-91-708-08-91

UK - Wokingham
Tel: 44-118-921-5869
Fax: 44-118-921-5820

12/08/06