

LOADING PATTERN MATING SIDE

f	6	6	6	6	6	6	6	6	6	6	6	6	6	6	6	6	6	6
e	5	5	5	5	5	5	5	5	5	5	5	5	5	5	5	5	5	5
d	5	5	5	5	5	5	5	5	5	5	5	5	5	5	5	5	5	5
c	5	5	5	5	5	5	5	5	5	5	5	5	5	5	5	5	5	5
b	5	5	5	5	5	5	5	5	5	5	5	5	5	5	5	5	5	5
a	5	5	5	5	5	5	5	5	5	5	5	5	5	5	5	5	5	5
z	6	6	6	6	6	6	6	6	6	6	6	6	6	6	6	6	6	6
POS	01																	
		05																
			10															
				15														
					19													

LOADED CONNECTOR ASSEMBLY (FOR EXAMPLE)

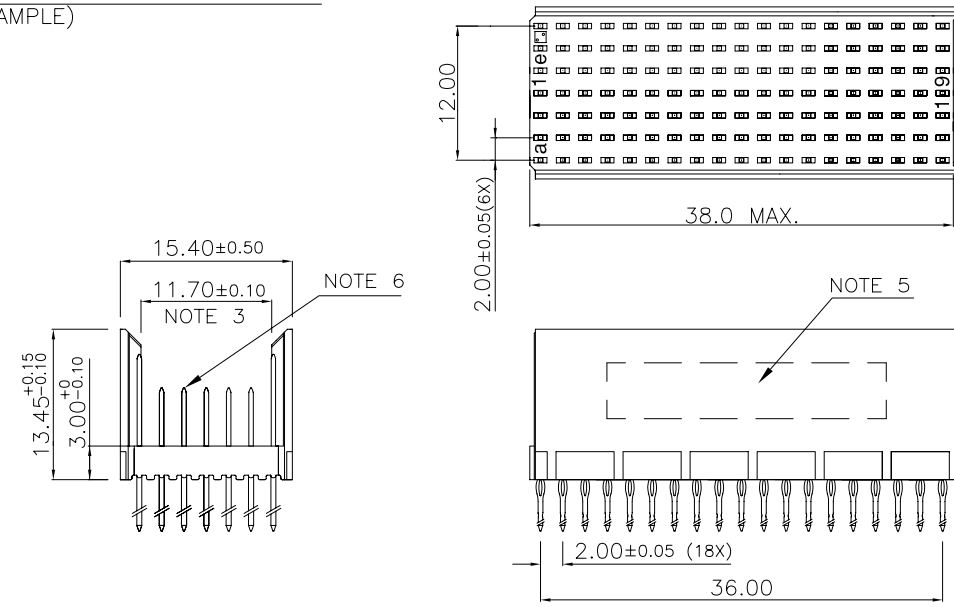

CONTACT OVERVIEW

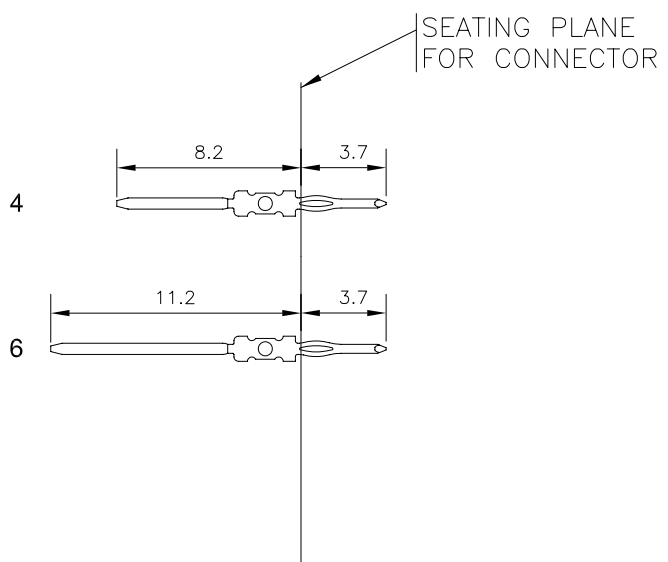

HM2P71PAE121-
 LEAD FREE INDICATOR : LF = LEAD FREE (DIGIT 15 & 16)
 PLATING CODE (DIGIT 13 AND 14)

PLATING TABLE

CODE	PLATING	CONTACT AREA	TYPE OF TERMINAL	PERFORMANCE LEVEL
AA	0.75μ Au	GOLD OVER NICKEL PLATING.	SHORT TERMINAL EON PRESSFIT CONTACTS	IEC PERFORMANCE LEVEL 2 (250 mating cycles) or TELCORDIA CO
AB	1.25μ Au	GOLD OVER NICKEL PLATING.	SHORT TERMINAL EON PRESSFIT CONTACTS	TELCORDIA UE

LAY-OUT P.C.B.-HOLE

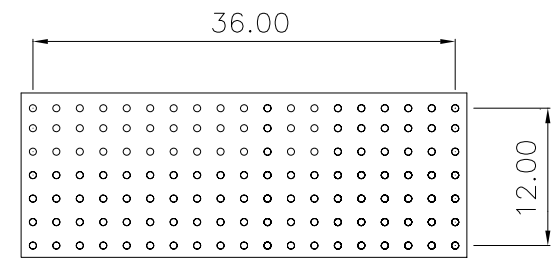

NOTES

- THIS PRODUCT IS CSA APPROVED.
 - THIS PRODUCT IS UL RECOGNIZED.
 - MEASURED AT THE BOTTOM.
 - MATERIAL CONTACT: PHOSPHOR BRONZE
HOUSING : CREAM WHITE GLASS FILLED POLYESTER UL-94V0
 - CONNECTOR PRINTED WITH P/N AND DATE CODE.
 - FOR ACTUAL CONTACT LOADINGS, SEE LOADING PATTERN MATING SIDE.
 - SHAPE OF CONNECTOR HOUSING CAN ALTER DEPENDING ON PRODUCTION LOCATION
 - THE PRODUCT (LF) MEETS EUROPEAN UNION DIRECTIVES AND OTHER COUNTRY REGULATIONS AS DESCRIBED IN GS-22-008
 - FOR RECOMMENDED PTH DIMENSIONS REFER DRAWING : BS, A , 201572 , 001
- CATALOG NO: HM2P71PAE121-----

mat'l. code		surface		tolerance		projection		product family	
SEE NOTE 4		ISO 1302 ✓		ISO 406 ISO 1101				MILLIPACS	
litr		ecn no		dr		date		title	
A		109-0210		MINI		2009-10-06		MPACS 5+2R STR HDR PF CONN TYPE B 19 POS.	
B		109-0290		AB		2009-12-29			
C		110-0018		MINI		2010-01-13			
				dr		MINI K VANDANATH 2009-10-06		dwg no	
				enr		ALEX BABU 2009-10-06		sheet 1 of 1	
				chr		ALEX BABU 2009-10-06		size	
				appd		ALEX BABU 2009-10-06		A3	
sheet index		revision sheet		c				type Product Customer Drawing	
		1							



Copyright FCI