

# 1.5A Buck Converter, 1.5A Boost Converter, and LDO Controller

## DESCRIPTION

Demonstration circuit 1106 is a 1.5A Buck Converter, 1.5A Boost Converter, and LDO Controller featuring the LT3570. The Buck is designed to convert a 4V to 36V source to 3.3V at 1A. The LDO is powered from the output of the Buck and converts it to 2.5V at 100mA. The Boost converts a 3.3V-10V source to 12V at 275mA. DC1106 was designed to switch at 500KHz.

In the DC1106 default setting, the Buck and Boost converters run from separate sources to allow for full input variation for the Buck. To facilitate other input options, there are two placeholders on the back of the board, R1 and R2. Installing a jumper at R1, allows the Boost output to power the Buck. Installing a jumper at R2, allows both, the Boost and the Buck to be powered from the same source.

Since the input to the Buck powers the internal oscillator, it needs to be on for the Boost to switch.

The LT3570 features programmable switching frequency, synchronization, external compensation, independent soft-start for each converter. This circuit is intended for space-conscious applications such as Cable Satellite Set-top Boxes, Automotive Systems, Telecom Systems “Dying Gasp” Systems and TFT LCD Displays.

The LT3570 datasheet gives a complete description of the part, operation and application information. The datasheet must be read in conjunction with this quick start guide for working on or modifying the demo circuit 1106.

**Design files for this circuit board are available. Call the LTC factory.**

 LTC, LTM, LT are registered trademarks of Linear Technology Corporation.

## PERFORMANCE SUMMARY FOR DC1106A Specifications are at TA = 25°C

SYMBOL	PARAMETER	CONDITIONS	MIN	TYP	MAX	UNITS
V <sub>IN BUCK</sub>	Input Supply Range		4		36	V
V <sub>IN BOOST</sub>	Input Supply Range		3.3		10	V
V <sub>OUT BUCK</sub>	Output Voltage Range	V <sub>IN</sub> = 4V-36V, I <sub>LOAD</sub> = 1A	3.2	3.3	3.4	V
V <sub>OUT BOOST</sub>	Output Voltage Range	V <sub>IN</sub> = 3.3V-10V, I <sub>LOAD</sub> = 275mA	11.64	12	12.36	V
V <sub>OUT LDO</sub>	Output Voltage Range	I <sub>LOAD</sub> = 100mA	2.425	2.5	2.575	V
3.3V RIPPLE		V <sub>IN</sub> = 4V, I <sub>LOAD</sub> = 1A		20		mV
12V RIPPLE		V <sub>IN</sub> = 12V, I <sub>LOAD</sub> = 275mA		150		mV
2.5V RIPPLE		I <sub>LOAD</sub> = 100mA		10		mV
EFFICIENCY		Both input sources at 5V, Loads: 3.3V = 1A, 12V = 275mA, 2.5V = 100mA		87		%

## QUICK START PROCEDURE

Demonstration circuit 1106 is easy to set up to evaluate the performance of the LT3570. Refer to Figure 1 for proper measurement equipment setup and follow the procedure below:

**NOTE.** When measuring the input or output voltage ripple, care must be taken to avoid a long ground lead on the oscilloscope probe. Measure the input or output voltage ripple by touching the probe tip directly across the Vin or Vout and GND terminals. See Figure 2 for proper scope probe technique.

1. Place jumpers in the following positions:

**JP1, JP2, JP3** On

2. With power off, connect the input power supplies to Vin and GND.

3. Turn on the power at the input.

Check for the proper output voltages.  $3.3V = 3.2$  to  $3.4$ ,  $12V_{out} = 11.64V$  to  $12.36V$ , and  $2.5V = 2.425V$  to  $2.575V$ .

**NOTE.** If there is no output, temporarily disconnect the load to make sure that the load is not set too high.

4. Once the proper output voltages are established, adjust the loads within the operating range and observe the output voltage regulation, ripple voltage, efficiency and other parameters.

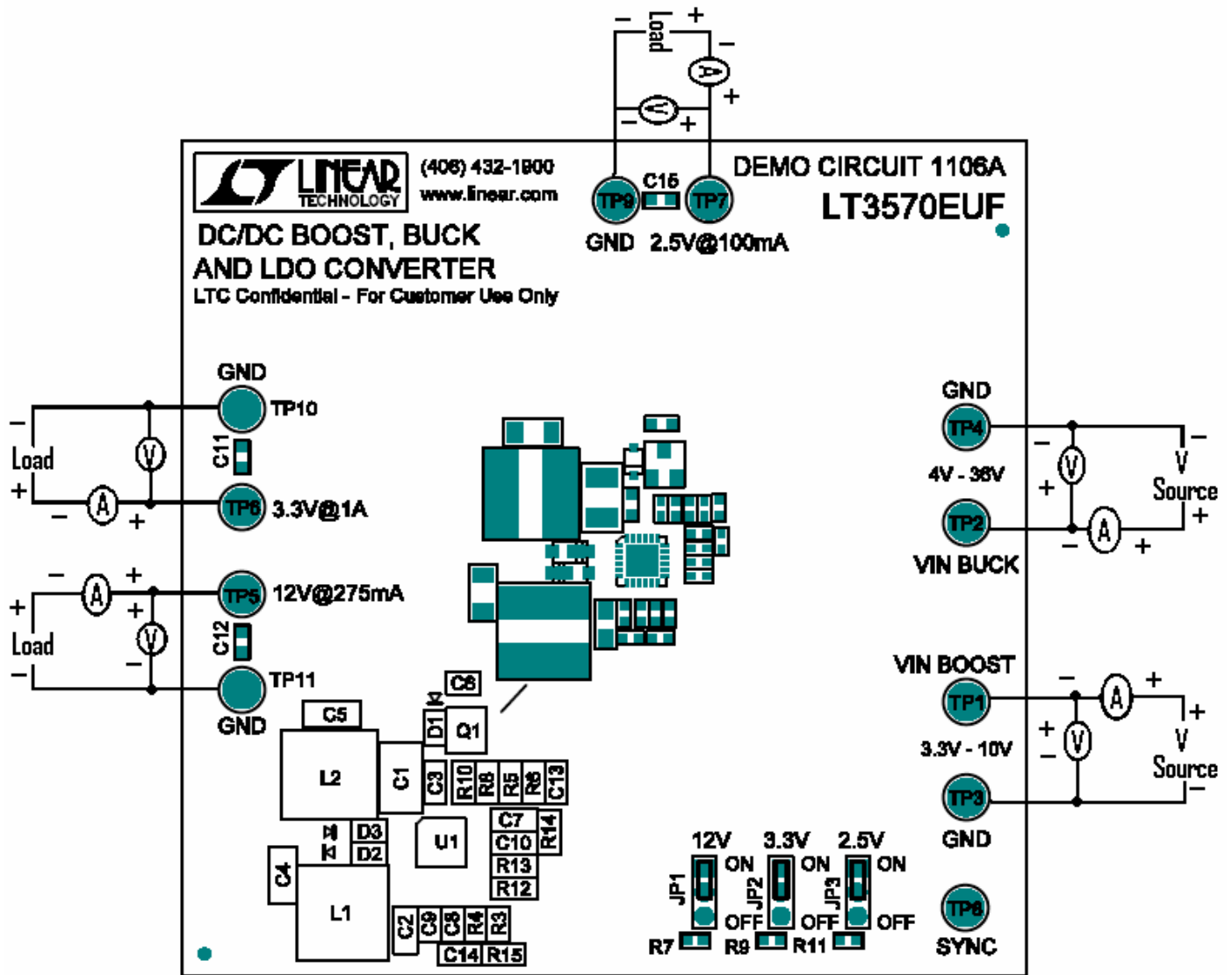

Figure 1. Proper Measurement Equipment Setup

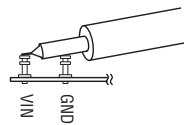

Figure 2. Measuring Input or Output Ripple

REVISION HISTORY				
ECO	REV	DESCRIPTION	DATE	APPROVED
	2	PROTO	05/14/08	

This circuit is proprietary to Linear Technology and supplied for use with Linear Technology parts.  
**Customer Notice:** Linear Technology has made a best effort to design a circuit that meets customer-specified specifications. It is the customer's responsibility to verify that the circuit meets their application and reliable operation in the actual application. Component substitution and printed circuit board layout may significantly affect circuit performance or reliability. Contact Linear Applications Engineering for assistance.

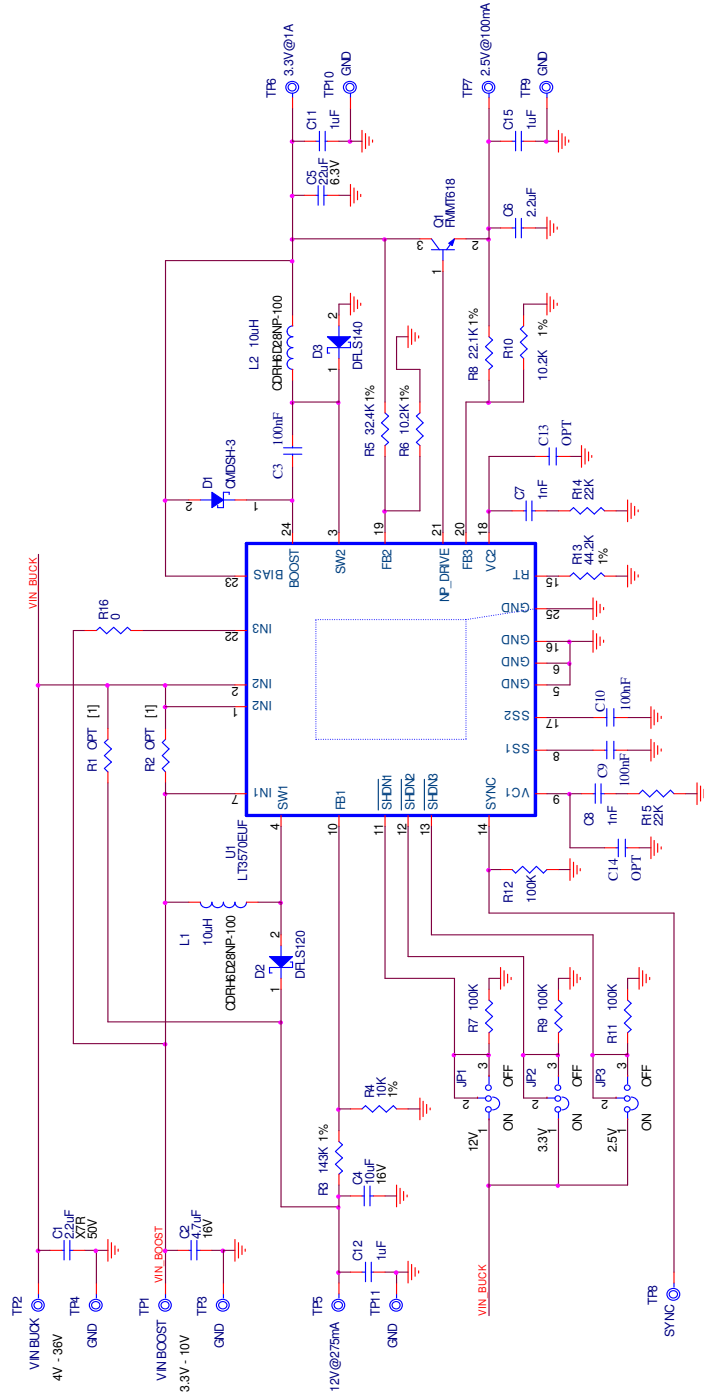

Figure 3. Schematic

NOTES: UNLESS OTHERWISE SPECIFIED,  
 (1) DO NOT STUFF.

UNLESS OTHERWISE SPECIFIED DIMENSIONS ARE IN MILLIMETERS TOLERANCE ON ANGLES ... 2 PLACES ... 3 PLACES ... INTERPRET DIM AND TOL PER ASME Y14.5M-1994		CONTRACT NO.		DATE	
THIRD ANGLE PROJECTION		DRAWN: MEI		05/10/08	
		APPROVED			
		ENGINEER			
		DESIGNER			
DO NOT SCALE DRAWING		Monday, August 04, 2008		SCALE NONE	
		FLENAME: 1106A-2.DSN		SHEET 1 OF 1	
		TITLE		DWG NO	
		SCH, LT3570EUF, DC/DC BOOST, BUCK AND LDO CONVERTER		DC1106A	
		SIZE		REV	
		Custom		2	

**LINEAR TECHNOLOGY**  
 9530 McCarty Blvd  
 Milpitas, CA 95025  
 Phone: (408) 432-1800  
 Fax: (408) 432-3200