

TL6150 SERIES TACT SWITCH

ANTI-VANDAL SWITCHES
DETECTOR SWITCHES
DIP SWITCHES
KEYLOCK SWITCHES
NAVIGATION SWITCHES
PUSHBUTTON SWITCHES
ROCKER SWITCHES
ROTARY SWITCHES
SLIDE SWITCHES
SNAP ACTION SWITCHES
TACTILE SWITCHES
TOGGLE SWITCHES
CAP OPTIONS



APPLICATIONS / MARKETS



RoHS

SPECIFICATIONS

Contact Rating: 50mA, 12VDC
Electrical Life: up to 5,000,000 Cycles
Contact Resistance: 100mΩ Max. (Initial)
Insulation Resistance: 10MΩ Min. at 100VDC
Dielectric Strength: 250VAC for 1 Minute
Operating Temperature: -40°C to 85°C
Operating Force: 160gf ± 50gf (5,000,000 cycles)
 200gf ± 50gf (500,000 cycles)
 350gf ± 100gf (300,000 cycles)
Travel: 0.3mm; 160gf
 0.35mm; 200gf
 0.5mm; 350gf
Dust/Moisture Protection: IP67
Function: SPST, Off-(On)

FEATURES & BENEFITS

- Up to 5,000,000 cycle life expectancy
- Tape and Reel packaging
- IP67 ratings
- Multiple force options

PART NUMBER CONFIGURATOR

Series	Circuit	Actuator	Force	Plating	Termination
<input type="text" value="TL"/>	<input type="text" value="6150"/>	<input type="text" value="A - 3.50"/> <input type="text" value="B - 5.20"/>	<input type="text" value="F160 - 160 gf - Brown"/> <input type="text" value="F200 - 200 gf - Red"/> <input type="text" value="F350 - 350 gf - Orange"/>	<input type="text" value="Q - Silver"/>	<input type="text" value="G - Gull Wing"/> <input type="text" value="J - J Lead"/>

Specifications subject to change without notice 12.3.2020



E-SWITCH®

www.e-switch.com

800.867.2717

1

TL6150 SERIES TACT SWITCH

BODY DIMENSIONS GULL WING

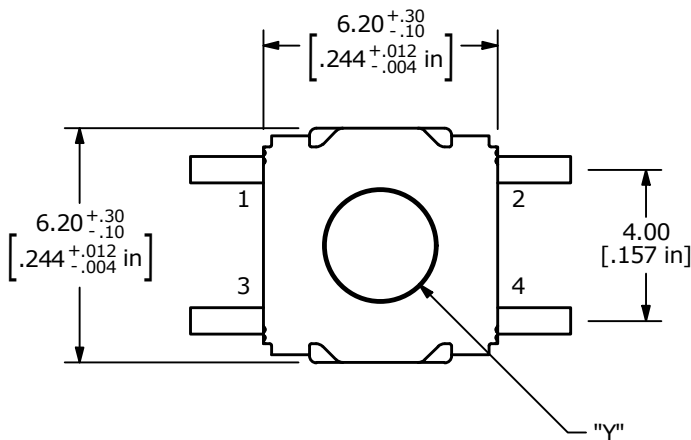
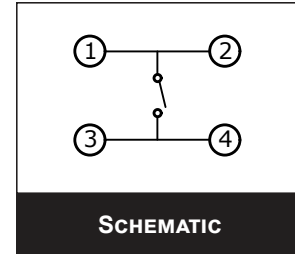
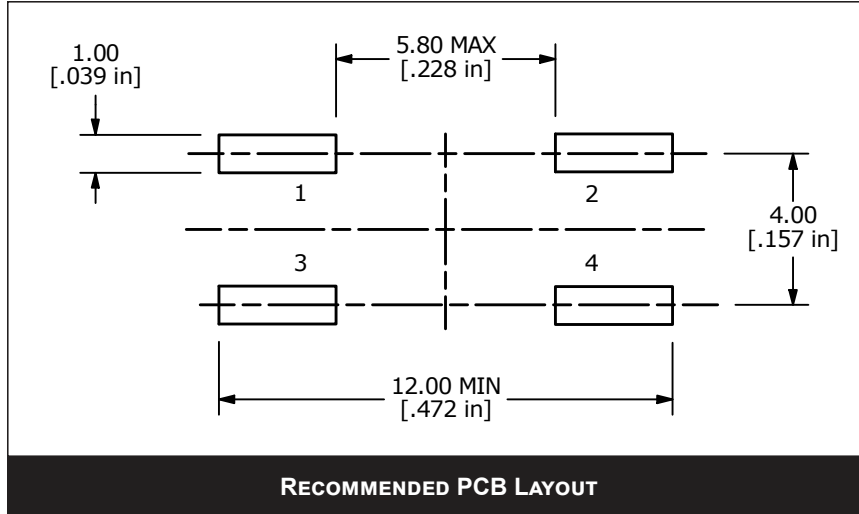

ACTUATOR	"X"	"Y"
A	3.50	2.90
B	5.20	2.70

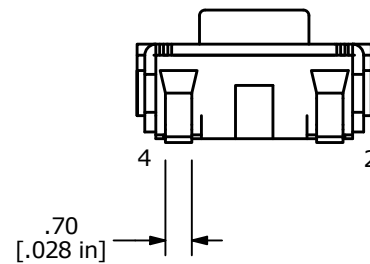
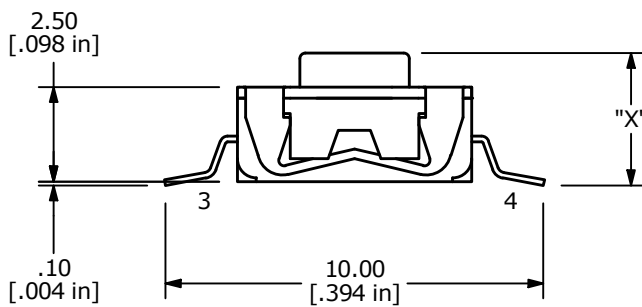

TL6150 SERIES TACT SWITCH

BODY DIMENSIONS J LEAD

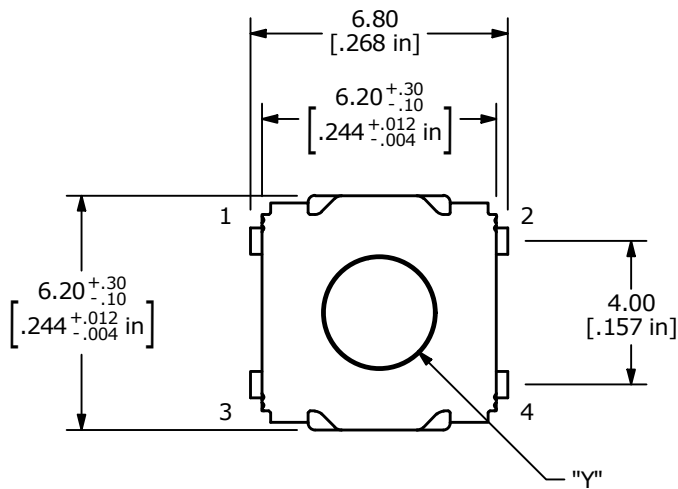
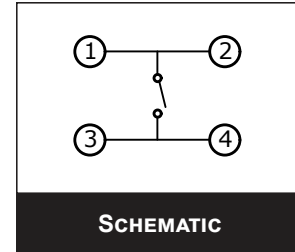
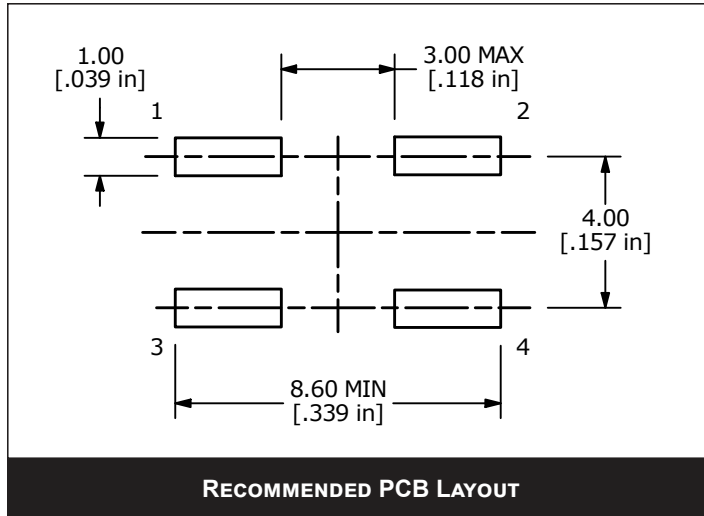

ACTUATOR	"X"	"Y"
A	3.50	2.90
B	5.20	2.70

