

KEYING OPTION "A"
SUGGESTED COLOR: BLACK

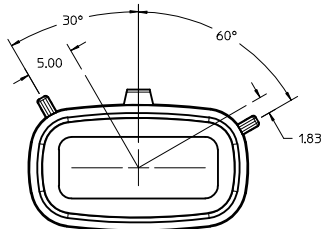

KEYING OPTION "B"
SUGGESTED COLOR: GREY

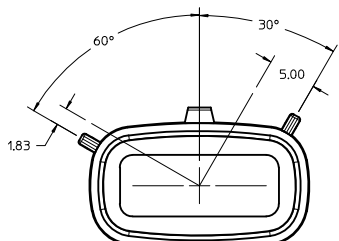

KEYING OPTION "C"
SUGGESTED COLOR: BROWN

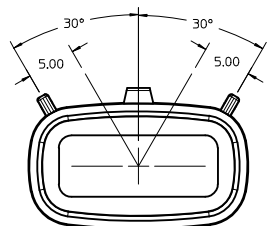

KEYING OPTION "D"
SUGGESTED COLOR: GREEN

CUSTOMER SHROUD DESIGN DETAILS

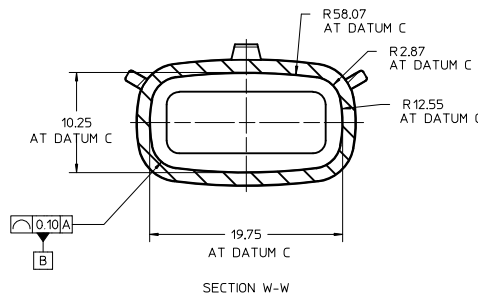
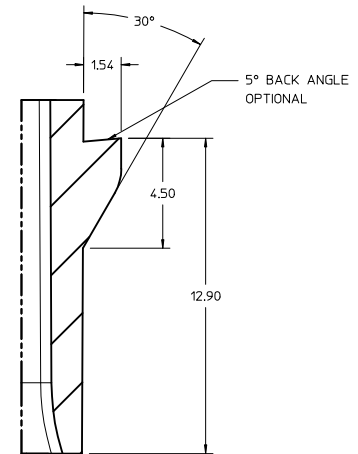
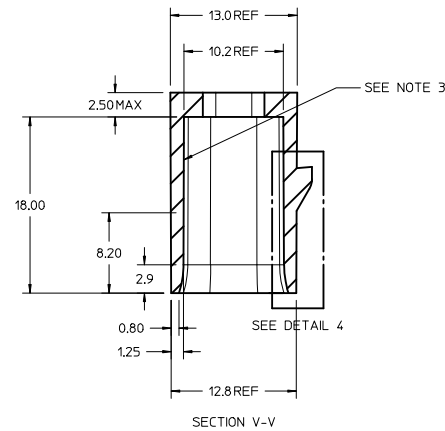
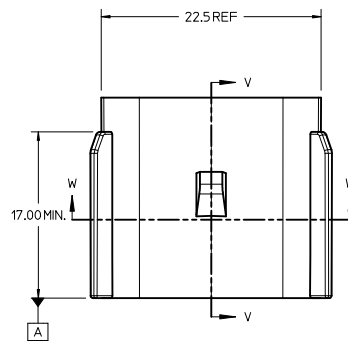
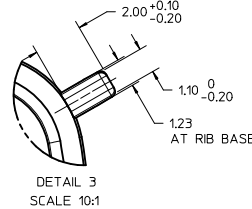
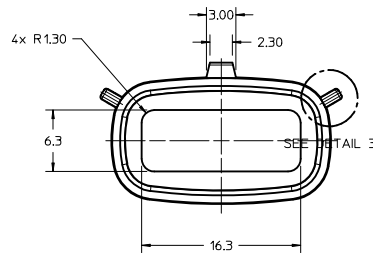

NOTES:

1. REFER TO MOLEX SALES DRAWING SD-75900-002 FOR THE HEADER ASSEMBLY PRODUCT DETAILS AND RECOMMENDED PCB LAYOUT.
2. KEYING OPTIONS A-D AND SUGGESTED COLORS COMPLY TO THE POLARIZATION STANDARDS ESTABLISHED FOR MATING WITH A MX150 FEMALE CONNECTOR.
3. INTERIOR SHROUD SURFACE MUST BE FREE OF DEFECTS AND PARTING LINES ALL AROUND TO ENSURE PROPER SEALING OF THE MATING MX150 FEMALE CONNECTOR.
4. A FULL SHROUD ON THE MATING CONNECTOR IS REQUIRED TO INSURE THE HEADER SHROUD POLARIZATION FEATURES (OPTIONS A-D) WILL FUNCTION PROPERLY. THE FULL SHROUD ALSO PREVENTS SCOOP DAMAGE TO THE HEADER CONTACTS.
5. PERMISSIBLE DRAFT ANGLE 0.25° MAXIMUM.
6. RADII ON ALL CORNERS SHOWN SHARP OR ALL UNSPECIFIED RADII 0.25 EXCEPT AS NOTED.
7. DIMENSIONS SHOWN ABOUT A CENTERLINE ARE SYMMETRICAL ABOUT THAT CENTERLINE WITHIN HALF THE SPECIFIED TOLERANCE.

INITIAL RELEASE EC NO: UCP2011-3372 DRAWN BY: DROSCA CHECKED BY: JCOMERC I APPROVED BY: JCOMERC I DATE: 2011/06/17 DATE: 2011/06/17 DATE: 2011/06/17	QUALITY SYMBOLS ▽=0 ▽=0	GENERAL TOLERANCES (UNLESS SPECIFIED)		DIMENSION STYLE MM ONLY	SCALE 4:1	DESIGN UNITS METRIC	THIRD ANGLE PROJECTION		
		4 PLACES ± --- INCH 3 PLACES ± --- INCH 2 PLACES ± 0.10 INCH 1 PLACE ± 0.2 INCH	4 PLACES ± --- MM 3 PLACES ± --- MM 2 PLACES ± 0.10 MM 1 PLACE ± 0.2 MM	DRAWN BY: DROSCA CHECKED BY: JCOMERC I APPROVED BY: JCOMERC I	DATE: 2011/06/17 DATE: 2011/06/17 DATE: 2011/06/17	TITLE: APPLICATION SPEC 1X4 MX150 HEADER SHROUD DETAILS	MOLEX MOLEX INCORPORATED		
		DRAFT WHERE APPLICABLE MUST REMAIN WITHIN DIMENSIONS		MATERIAL NO: 759001040	DOCUMENT NO: AS-75900-104	SHEET NO: 1 OF 2			
		THIS DRAWING CONTAINS INFORMATION THAT IS PROPRIETARY TO MOLEX INCORPORATED AND SHOULD NOT BE USED WITHOUT WRITTEN PERMISSION							

HEADER APPLICATION DETAILS

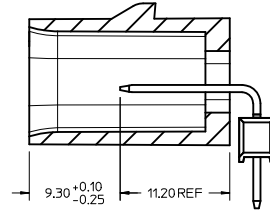
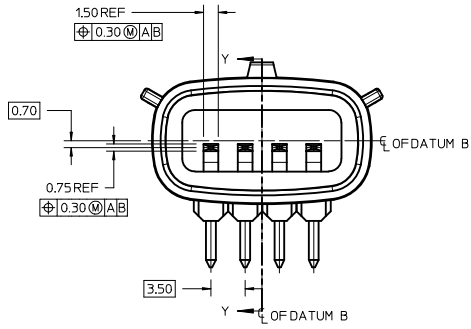

SECTION Y-Y

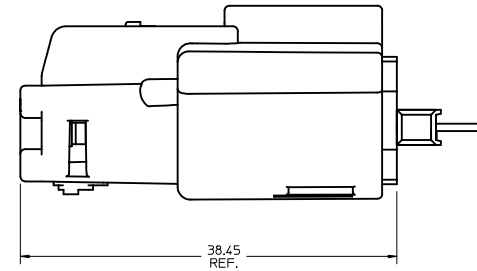
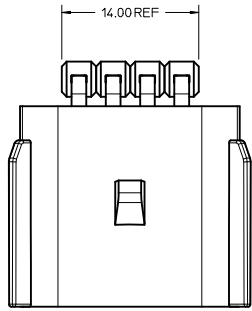
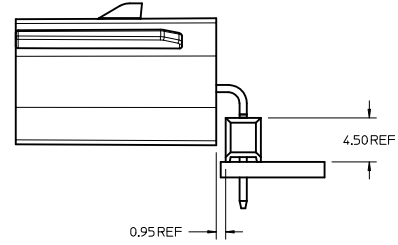

CONNECTOR ASSEMBLY

NOTES:

- ADHERENCE TO THE HEADER APPLICATION DETAILS IS IMPERATIVE TO ENSURE PROPER SHROUD SEALING AND CONTACT ALIGNMENT WHEN MATED WITH A MX150 FEMALE CONNECTOR.

SEE SHEET 1 IEC NO: UCP2011-3372 DRAWN BY: DROSCA 2011/06/17 CHECKED BY: JCOMERCI 2011/06/17 APPR: JCOMERCI 2011/06/17	QUALITY SYMBOLS	GENERAL TOLERANCES (UNLESS SPECIFIED)	DIMENSION STYLE	SCALE	DESIGN UNITS	THIRD ANGLE PROJECTION
	$\nabla = 0$ $\nabla = 0$	mm INCH 4 PLACES ± --- ± --- 3 PLACES ± --- ± --- 2 PLACES ± 0.10 ± --- 1 PLACE ± 0.2 ± --- ANGULAR ± 1/2°	MM ONLY	4:1	METRIC	
	DESCRIPTION	DRAFT WHERE APPLICABLE MUST REMAIN WITHIN DIMENSIONS	DRAWN BY: DROSCA 2011/06/17	DATE: 2011/06/17	TITLE: APPLICATION SPEC 1X4 MX150 HEADER SHROUD DETAILS	MOLEX INCORPORATED
	1 1		CHECKED BY: JCOMERCI 2011/06/17 APPROVED BY: JCOMERCI 2011/06/17	MATERIAL NO.: SEE SHEET 1 DOCUMENT NO.: AS-75900-104	SHEET NO.: 2 OF 2	

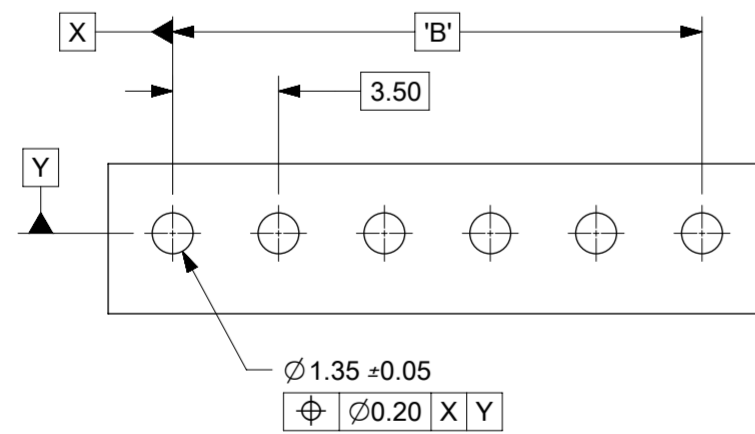
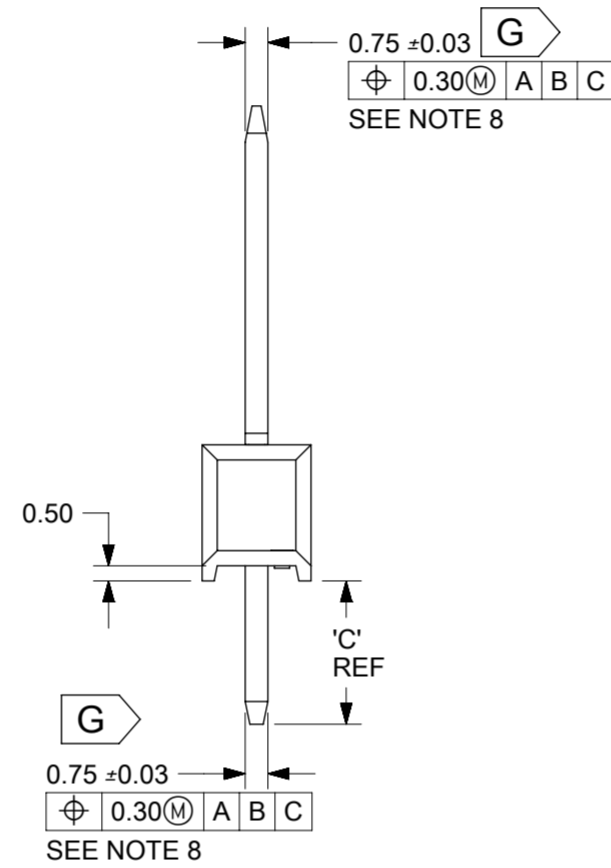
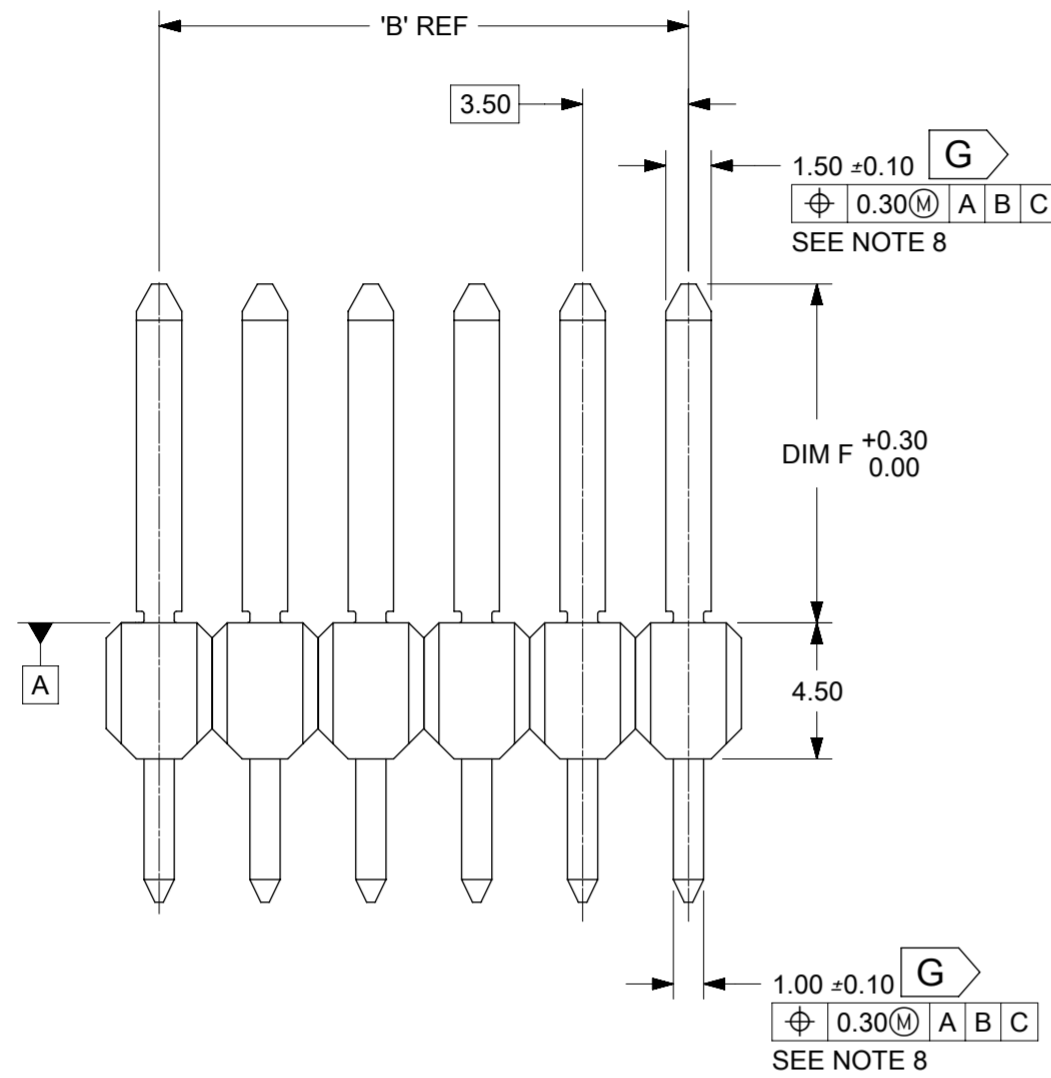
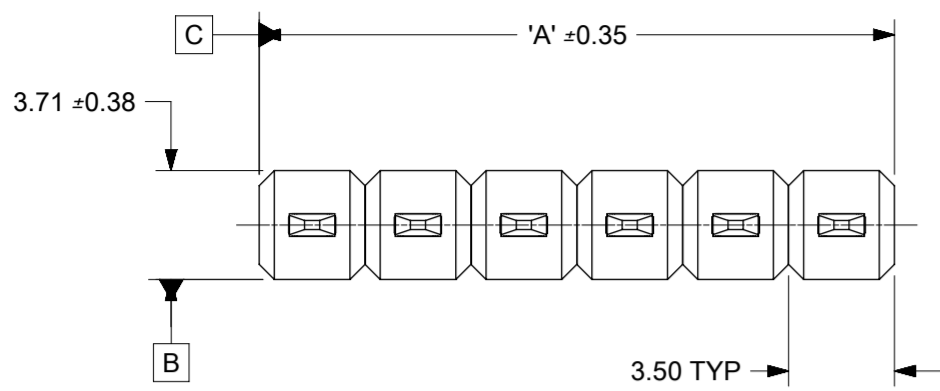

RECOMMENDED PCB LAYOUT

NOTES:

1. TERMINAL MAT'L: ALLOY C26000, CARTRIDGE BRASS
2. WAFER MAT'L: 30% GLASS FILLED LCP, 94V-0, COLOR BLACK.
3. TERMINAL PLATING:
 OPTION 1 - 2.5µm MIN MATTE TIN OVERALL OVER 1.50µm MIN. NICKEL OVERALL
 OPTION 2 - 1.50µm MIN. NICKEL OVERALL 4.00µm MIN SELECT MATTE TIN PC TAIL AREA 0.05µm MIN SELECT GOLD CONTACT AREA
 OPTION 3 - 1.50µm MIN. NICKEL OVERALL 4.00µm MIN SELECT MATTE TIN PC TAIL AREA 0.50µm MIN. SELECT GOLD CONTACT AREA
 OPTION 4 - 1.5µm MIN MATTE TIN OVERALL OVER 1.50µm MIN. NICKEL OVERALL
4. HEADER ASSEMBLIES ARE TUBE PACKAGED PER PK-36518-342.
5. MAXIMUM SKIVING ALLOWED: 1mm.
6. MAXIMUM CUT-OFF BURR ALLOWED: 0.30mm.
7. MAXIMUM DIG MARK ALLOWED: 0.45mm.
8. ALL THE POSITIONAL TOLERANCES SHOULD BE MEASURED AT TIP OF THE TERMINALS.
9. POSITION TOLERANCE OF PIN AT MATING SIDE SHOULD BE MAINTAINED AT 0.3MM IN THE FINAL MODULE BY CUSTOMER.
10. (G) DENOTES DIMENSIONS THAT CAN BE QUALIFIED WITH GAUGE
11. BLADE GEOMETRY DOES NOT CONFORM TO USCAR SPECIFICATIONS
12. PLEASE REFER USCAR WEBSITE FOR 1.5mm DIRECT CONNECT INTERFACE (SHROUD) DETAILS
13. PLEASE REFER SD-33472-0001 FOR 2 X 10 SHROUD DETAILS

SYMBOLS	THIS DRAWING CONTAINS INFORMATION THAT IS PROPRIETARY TO MOLEX ELECTRONIC TECHNOLOGIES, LLC AND SHOULD NOT BE USED WITHOUT WRITTEN PERMISSION										
	DIMENSION UNITS	SCALE	CURRENT REV DESC: Five PN's: 757570123, 757570133, 757570153, 757570221 & 757570443 ARE OBSOLETE								
∇ = 0	mm	4:1	GENERAL TOLERANCES (UNLESS SPECIFIED)								
∇ = 0	ANGULAR TOL ± 0.5°		EC NO: 633184							PRODUCT CUSTOMER DRAWING	
∇ = 0	4 PLACES ±		DRWN: RYELAVATTITH 2020/02/26							DOCUMENT NUMBER	
∇ = 0	3 PLACES ±		CHK'D: RYELAVATTITH 2020/03/02							SD-75757-010	
∇ = 0	2 PLACES ± 0.13		APPR: SNAYAK01 2020/03/02							DOC TYPE DOC PART REVISION	
∇ = 0	1 PLACE ± 0.25		INITIAL REVISION:							PSD 001 L5	
∇ = 0	0 PLACES ±		DRWN: TMCLELL 2006/01/27							MATERIAL NUMBER	
∇ = 0	DRAFT WHERE APPLICABLE MUST REMAIN WITHIN DIMENSIONS		THIRD ANGLE PROJECTION		DRAWING	SERIES	CUSTOMER		SHEET NUMBER		
∇ = 0			A2-SIZE		75757	GENERAL MARKET		1 OF 2			

		TOOLED				TOOLED				TOOLED				TOOLED				STATUS			
1 x 2	1	75757-0121				75757-0122	OBSOLETE			75757-0123	OBSOLETE			75757-0124				7	3.5		
	2	75757-0221	OBSOLETE			75757-0222	OBSOLETE			75757-0223	OBSOLETE			75757-0224	OBSOLETE						
	3	75757-0321	OBSOLETE			75757-0322	OBSOLETE			75757-0323	OBSOLETE			75757-0324	OBSOLETE						
	4	75757-0421	OBSOLETE			75757-0422	OBSOLETE			75757-0423	OBSOLETE			75757-0424	OBSOLETE						
1 x 3	1	75757-0131				75757-0132	OBSOLETE			75757-0133	OBSOLETE			75757-0134				10.5	7.00		
	2	75757-0231	OBSOLETE			75757-0232	OBSOLETE			75757-0233	OBSOLETE			75757-0234	OBSOLETE						
	3	75757-0331	OBSOLETE			75757-0332	OBSOLETE			75757-0333	OBSOLETE			75757-0334	OBSOLETE						
	4	75757-0431	OBSOLETE			75757-0432	OBSOLETE			75757-0433	OBSOLETE			75757-0434	OBSOLETE						
1 x 4	1	75757-0141				75757-0142	OBSOLETE			75757-0143	OBSOLETE			75757-0144	OBSOLETE			14.0	10.50		
	2	75757-0241	OBSOLETE			75757-0242	OBSOLETE			75757-0243	OBSOLETE			75757-0244	OBSOLETE						
	3	75757-0341	OBSOLETE			75757-0342	OBSOLETE			75757-0343	OBSOLETE			75757-0344	OBSOLETE						
	4	75757-0441				75757-0442	OBSOLETE			75757-0443	OBSOLETE			75757-0444	OBSOLETE						
1 x 5	1	75757-0151				75757-0152	OBSOLETE			75757-0153	OBSOLETE			75757-0154	OBSOLETE			17.5	14.00		
	2	75757-0251	OBSOLETE			75757-0252	OBSOLETE			75757-0253	OBSOLETE			75757-0254	OBSOLETE						
	3	75757-0351	OBSOLETE			75757-0352	OBSOLETE			75757-0353	OBSOLETE			75757-0354	OBSOLETE						
	4	75757-0451	OBSOLETE			75757-0452	OBSOLETE			75757-0453	OBSOLETE			75757-0454	OBSOLETE						
1 x 6	1	75757-0161				75757-0162	OBSOLETE			75757-0163	OBSOLETE			75757-0164	OBSOLETE			21.0	17.50		
	2	75757-0261	OBSOLETE			75757-0262	OBSOLETE			75757-0263	OBSOLETE			75757-0264	OBSOLETE						
	3	75757-0361	OBSOLETE			75757-0362	OBSOLETE			75757-0363	OBSOLETE			75757-0364	OBSOLETE						
	4	75757-0461	OBSOLETE			75757-0462	OBSOLETE			75757-0463	OBSOLETE			75757-0464	OBSOLETE						
CKT SIZE	PLATING OPTION	MATERIAL NUMBER	STATUS	"F" DIM	"C" DIM	MATERIAL NUMBER	STATUS	"F" DIM	"C" DIM	MATERIAL NUMBER	STATUS	"F" DIM	"C" DIM	MATERIAL NUMBER	STATUS	"F" DIM	"C" DIM	"A" DIM	"B" DIM		

SYMBOLS										THIS DRAWING CONTAINS INFORMATION THAT IS PROPRIETARY TO MOLEX ELECTRONIC TECHNOLOGIES, LLC AND SHOULD NOT BE USED WITHOUT WRITTEN PERMISSION									
DIMENSION UNITS		SCALE		CURRENT REV DESC: Five PN's: 757570123, 757570133, 757570153, 757570221 & 757570443 ARE OBSOLETE															
mm		1:1		<p>molex</p> <p>MX150 SINGLE ROW UNSHROUDED VERTICAL HEADER ASSEMBLY</p> <p>PRODUCT CUSTOMER DRAWING</p> <p>DOCUMENT NUMBER: SD-75757-010 DOC TYPE: PSD DOC PART: 001 REVISION: L5</p> <p>MATERIAL NUMBER: GENERAL MARKET CUSTOMER: GENERAL MARKET SHEET NUMBER: 2 OF 2</p>															
GENERAL TOLERANCES (UNLESS SPECIFIED)																			
ANGULAR TOL ± 0.5°																			
INITIAL REVISION:																			
▽ = 0	4 PLACES ±	DRWN: RYELAVATTITH 2020/02/26																	
▽ = 0	3 PLACES ±	CHK'D: RYELAVATTITH 2020/03/02																	
▽ = 0	2 PLACES ± 0.13	APPR: SNAYAK01 2020/03/02																	
▽ = 0	1 PLACE ± 0.25	DRWN: TMCLELL 2006/01/27																	
□ = 0	0 PLACES ±	APPR: MBANAKIS 2006/02/03																	
■ = 0	DRAFT WHERE APPLICABLE MUST REMAIN WITHIN DIMENSIONS		THIRD ANGLE PROJECTION		DRAWING		SERIES		MATERIAL NUMBER		CUSTOMER		SHEET NUMBER						
▽ = 0			A2-SIZE		75757		GENERAL MARKET		2 OF 2										