

PART NAME

FREEDOM FRDM-KL25Z BOARD ENCLOSURE

PART No.

FBB-3665

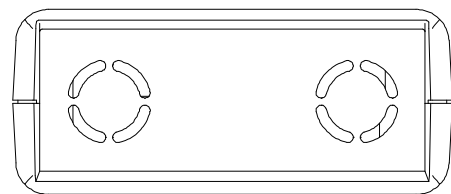

VIEW 1
INSIDE VIEW OF BOTTOM
SEE SECTION A-A FOR DETAILS

VIEW 2
INSIDE VIEW OF TOP
SEE SECTION A-A FOR DETAILS

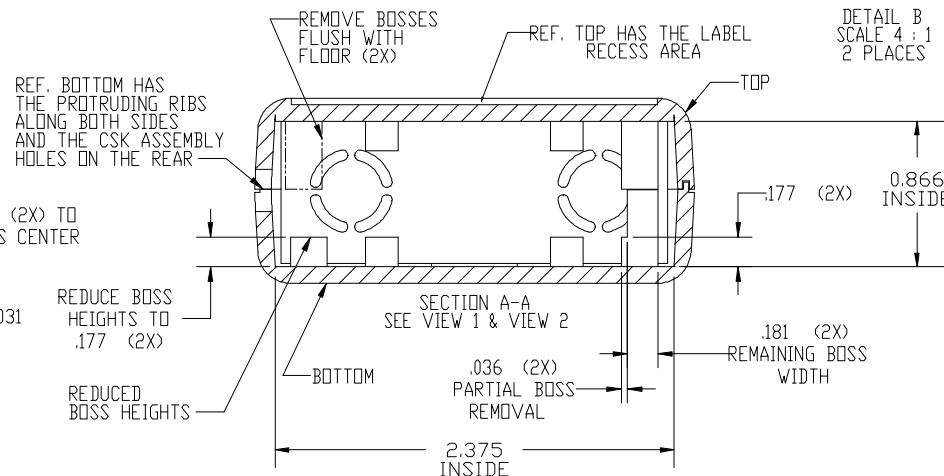
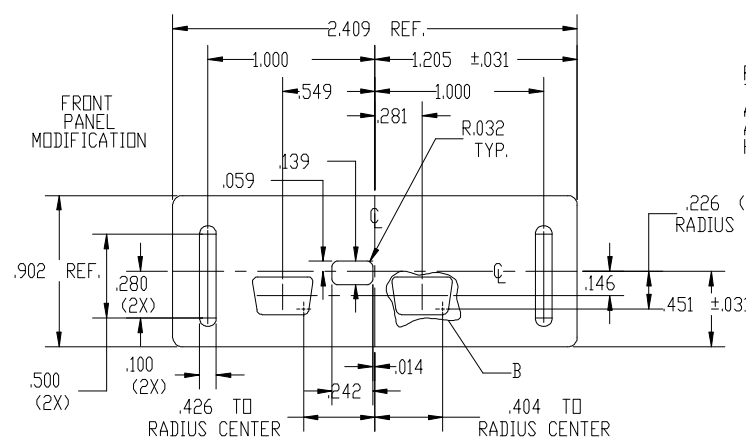
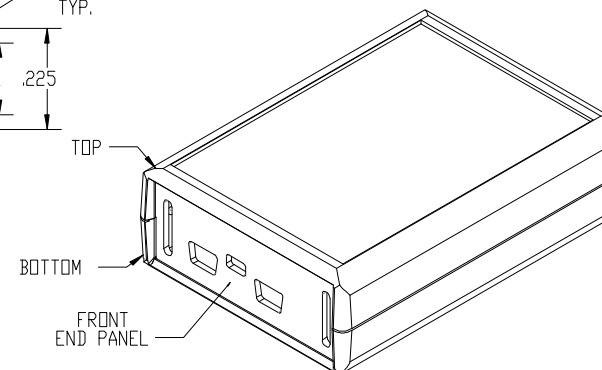
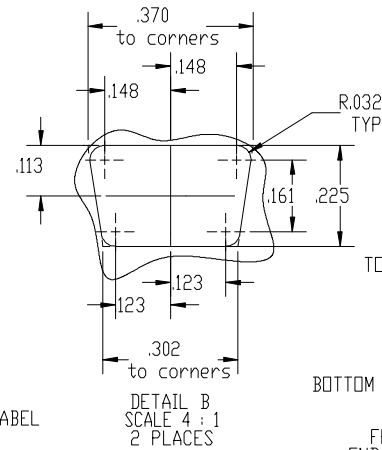
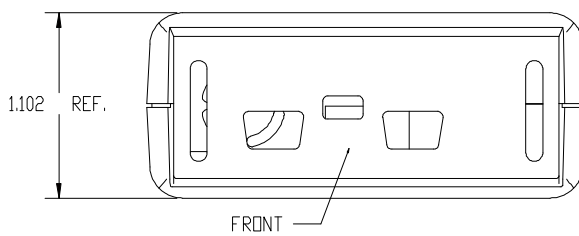
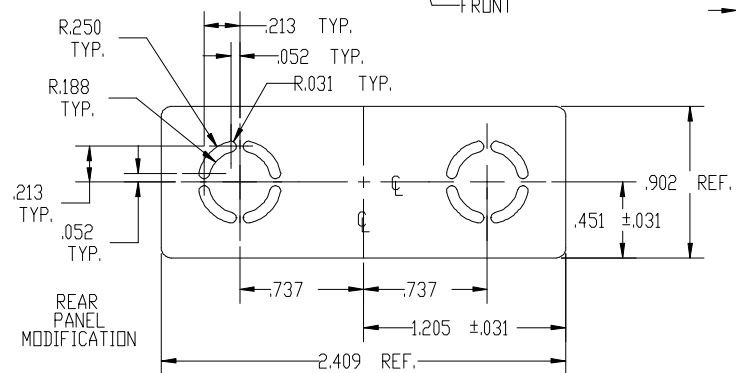
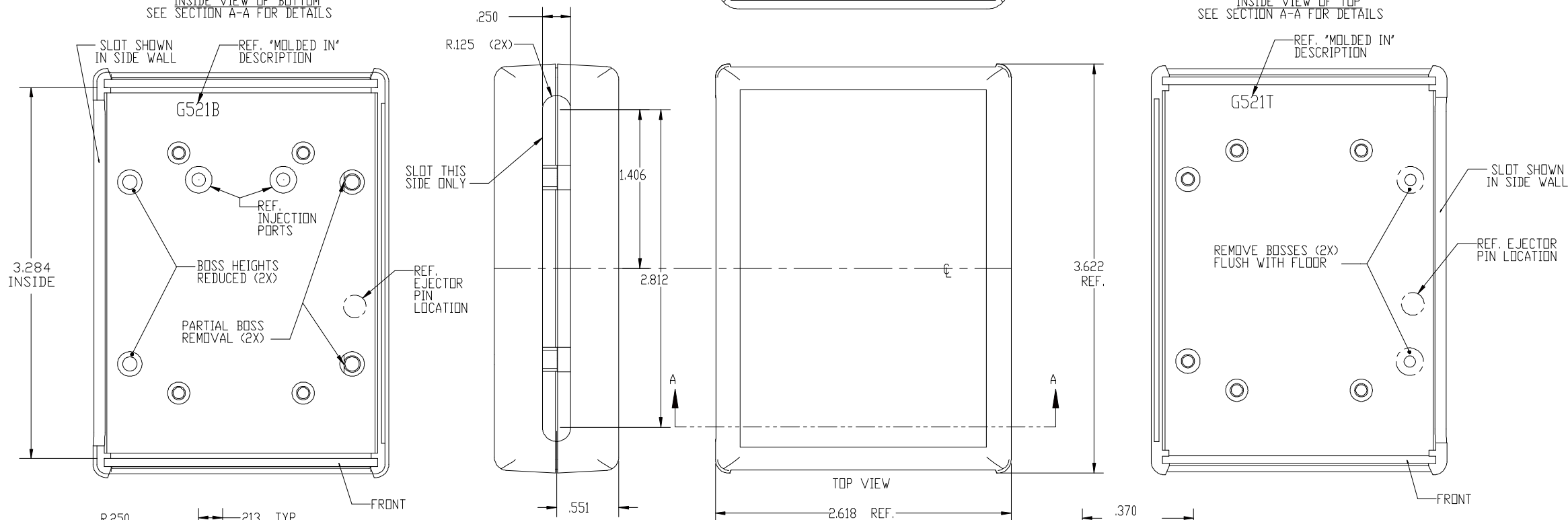

- NOTES:
1. THIS IS A BUD STANDARD HP-3651-B MODIFIED WITH CUSTOM CUTOUTS, BOSSES REMOVED, AND BOSSES MODIFIED.
 2. MUST BE ASSEMBLED AND ORIENTED AS SHOWN.
 3. MATERIAL/FINISH: ABS/BLACK