





# SPECIFICATIONS

**CUSTOMER** : \_\_\_\_\_  
**MODEL NO.** : **GFG128064F-FPFA-01**  
**VERSION** : **C**  
**DATE** : **2022.12.20**  
**CERTIFICATION** : **ROHS**

| Customer Sign | Approved By                                                                         | Prepared By                                                                          | Prepared By                                                                           |
|---------------|-------------------------------------------------------------------------------------|--------------------------------------------------------------------------------------|---------------------------------------------------------------------------------------|
|               |  |  |  |

晶發科技股份有限公司  
GI FAR TECHNOLOGY CO.,LTD

新北市樹林區東豐街 81 號

No. 81, Dongfeng St, Shulin District, 238034, New Taipei City, Taiwan, R.O.C.

TEL: +886-2-8684-1188 FAX: +886-2-8684-8532





## CONTENTS

|                                                      |       |    |
|------------------------------------------------------|-------|----|
| 1. Scope                                             | ----- | 4  |
| 2. Product Specifications                            | ----- | 4  |
| 2.1 General                                          | ----- | 4  |
| 2.2 Mechanical Characteristics                       | ----- | 4  |
| 2.3 Absolute Maximum Ratings                         | ----- | 5  |
| 2.4 Electrical Characteristics                       | ----- | 5  |
| 2.5 Optical Characteristics Absolute maximum ratings | ----- | 5  |
| 2.6 Optical Characteristics                          | ----- | 6  |
| 2.7 LED Back-light Characteristics                   | ----- | 7  |
| 3. Reliability                                       | ----- | 8  |
| 4. Operating Instructions                            | ----- | 9  |
| 4.1 Input signal Function                            | ----- | 9  |
| 4.2 Voltage Generator Circuit                        | ----- | 10 |
| 4.3 Timing Diagram                                   | ----- | 13 |
| 5. Notes                                             | ----- | 16 |
| 6. Operation Precautions                             | ----- | 16 |
| 7. LCM Dimensions                                    | ----- | 17 |
| 8. Package information                               | ----- | 18 |
| Appendix : Inspection Standard                       |       |    |



## 1. SCOPE

This specification covers the engineering requirements for the GFG128064F-FPFA-01 liquid crystal module.

## 2. PRODUCT SPECIFICATIONS

### 2.1 General

- 128 × 64 dot matrix LCD
- FSTN , Positive mode LCD panel
- Transflective , Normal temperature type
- 6 o'clock
- Back light: Edge LED (WHITE)
- Multiplexing driving : 1/64duty, 1/9bias
- Conteroller IC UC1601

### 2.2 Mechanical Characteristics

| Item                                                      | Characteristic       |
|-----------------------------------------------------------|----------------------|
| Dot configuration                                         | 128 × 64             |
| Dot dimensions(mm)                                        | 0.399 × 0.431        |
| Dot spacing (mm)                                          | 0.429 × 0.461        |
| Module dimensions (Horizontal × Vertical × Thickness, mm) | 65 × 47.5 × 8.5 max. |
| Viewing area (Horizontal × Vertical, mm)                  | 59 × 33.5            |
| Active area (Horizontal × Vertical, mm)                   | 54.882 × 29.474      |



## 2.3 Absolute Maximum Ratings (Without LED back-light)

| Characteristic            | Symbol   | Unit | Value                |
|---------------------------|----------|------|----------------------|
| Operating Voltage (logic) | $V_{DD}$ | V    | -0.3 to +4.0         |
| Input Voltage             | $V_{IN}$ | V    | -0.3 to $V_{DD}+0.3$ |

Note 1: Referenced to  $V_{SS}=0V$

## 2.4 Electrical Characteristics (Without LED back-light)

| Symbol       | Parameter                  | Conditions                         | Min.        | Typ. | Max.        | Unit      |
|--------------|----------------------------|------------------------------------|-------------|------|-------------|-----------|
| $V_{DD}$     | Supply for digital circuit |                                    | 2.4         |      | 3.3         | V         |
| $V_{DD2/3}$  | Supply for bias & pump     |                                    | 2.4         |      | 3.3         | V         |
| $V_{LCD}$    | Charge pump output         | $V_{DD2/3} \geq 2.4V, 25^{\circ}C$ |             |      | 11.5        | V         |
| $V_D$        | LCD data voltage           | $V_{DD2/3} \geq 2.4V, 25^{\circ}C$ | 0.80        |      | 1.32        | V         |
| $V_{IL}$     | Input logic LOW            |                                    |             |      | $0.2V_{DD}$ | V         |
| $V_{IH}$     | Input logic HIGH           |                                    | $0.8V_{DD}$ |      |             | V         |
| $V_{OL}$     | Output logic LOW           |                                    |             |      | $0.2V_{DD}$ | V         |
| $V_{OH}$     | Output logic HIGH          |                                    | $0.8V_{DD}$ |      |             | V         |
| $I_L$        | Input leakage current      |                                    |             |      | 1.5         | $\mu A$   |
| $R_{O(SEG)}$ | SEG output impedance       | $V_{LCD} = 11V$                    |             | 2    | 3           | $k\Omega$ |
| $R_{O(COM)}$ | COM output impedance       | $V_{LCD} = 11V$                    |             | 2    | 3           | $k\Omega$ |
| $F_{FR}$     | Average Frame Rate         | $LC[3] = 0b$                       | 66          | 76   | --          | Hz        |

## 2.5 Optical Characteristics Absolute maximum ratings

| Item                        | Symbol | Rating | Unit        |
|-----------------------------|--------|--------|-------------|
| Operating temperature range | Top    | 0~50   | $^{\circ}C$ |
| Storage temperature range   | Tst    | -20~70 | $^{\circ}C$ |



## 2.6. Optical Characteristics

1/64 duty, 1/9 bias,  $V_{op}=10.2\text{ V}$ ,  $T_a=25^\circ\text{C}$

| Item                | Symbol                    | Conditions                           | Min.       | Typ. | Max   | Reference   |
|---------------------|---------------------------|--------------------------------------|------------|------|-------|-------------|
| Driving voltage     | $V_{op}$                  |                                      | 9.9        | 10.2 | 10.5  |             |
| Viewing angle       | $\theta_1 \cdot \theta_2$ | $C \geq 2.0, \Phi = 0^\circ\text{C}$ | $30^\circ$ | -    | -     | Notes 1 & 2 |
| Contrast            | C                         | $\theta = 5^\circ, \Phi = 0^\circ$   | 2.0        | -    | -     | Note 3      |
| Response time(rise) | $t_{on}$                  | $\theta = 5^\circ, \Phi = 0^\circ$   | -          | 240  | 350ms | Note 4      |
| Response time(fall) | $t_{off}$                 | $\theta = 5^\circ, \Phi = 0^\circ$   | -          | 245- | 350ms | Note 4      |

Note 1: Definition of angles  $\theta$  and  $\Phi$

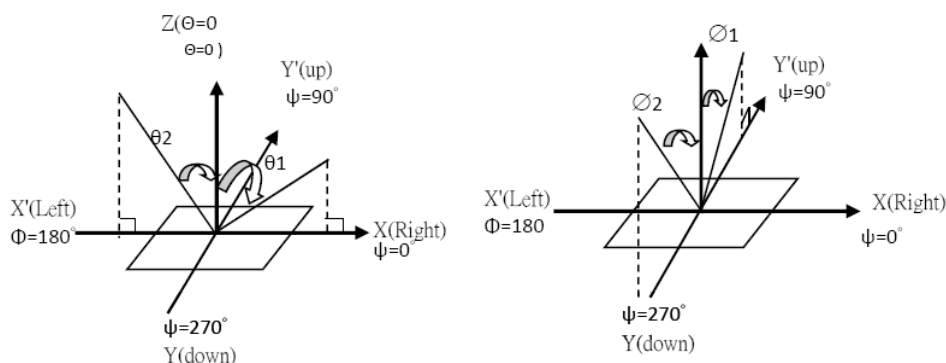

Note 2: Definition of viewing angles  $\theta_1$  and  $\theta_2$

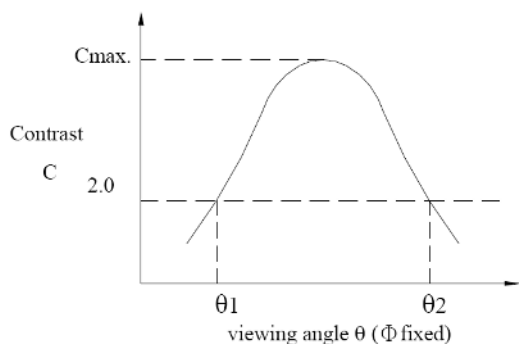

Note : Optimum viewing angle with the naked eye and viewing angle  $\theta$  at  $C_{max}$ . Above are not always the same

Note 3: Definition of contrast C

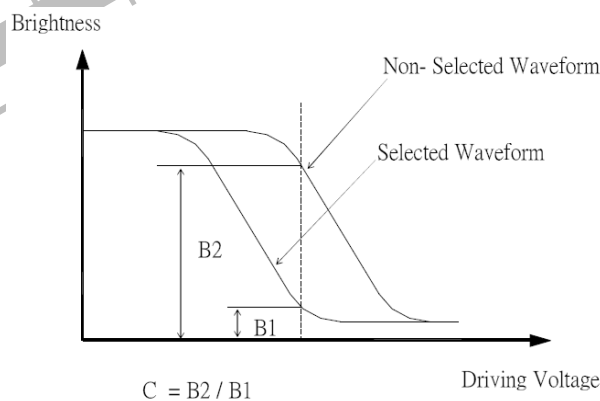

Note 4: Definition of response time

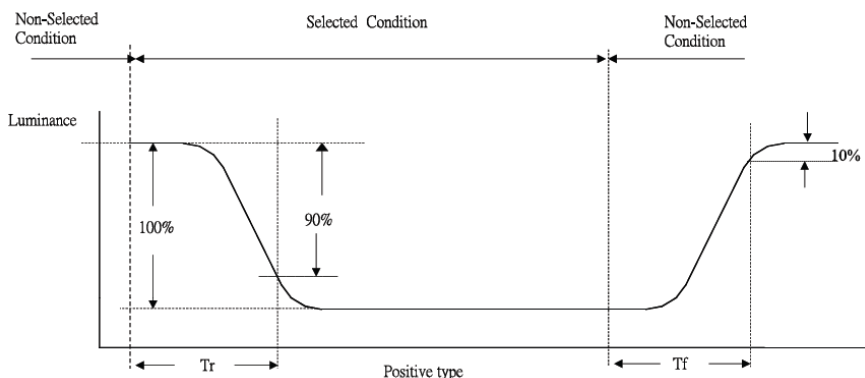



## 2.7 LED Back-light Characteristics

### 2.7.1 Electrical / optical specifications

Ta = 25°C

| Item                          | Symbol       | Condition         | Min. | Typ. | Max. | Unit              |
|-------------------------------|--------------|-------------------|------|------|------|-------------------|
| Forward voltage               | $V_f$        | If=45mA,<br>WHITE | 2.7  | 3.0  | 3.3  | V                 |
| LED<br>*Luminous<br>Intensity | $I_v$        | If=45mA,<br>WHITE | 150  | 200  | --   | cd/m <sup>2</sup> |
| Chromaticity<br>Coordinate    | x            | If=45mA,<br>WHITE | 0.25 | 0.28 | 0.31 |                   |
|                               | y            |                   | 0.26 | 0.29 | 0.32 |                   |
| Reverse Current               | $I_R$        | VR=5V,<br>WHITE   | --   | --   | 0.45 | mA                |
| Luminous<br>Uniformity        | $\Delta L_v$ | If=45mA,<br>WHITE | 70   |      |      | %                 |

Note: \* Measured at the bare LED back-light unit.

### 2.7.2 LED Maximum Operating Range

| Item              | Symbol   | WHITE | Unit |
|-------------------|----------|-------|------|
| Power Dissipation | $P_{AD}$ | 190   | mW   |
| Forward Current   | $I_F$    | 60    | mA   |
| Reverse Voltage   | $V_R$    | 5     | V    |



### 3. RELIABILITY

| NO. | ITEM                            | CONDITION                                                                                                         |         | STANDARD                     | NOTE      |
|-----|---------------------------------|-------------------------------------------------------------------------------------------------------------------|---------|------------------------------|-----------|
| 1   | High Temp. Storage              | 70°C                                                                                                              | 120 hrs | Appearance<br>Without defect |           |
| 2   | Low Temp. Storage               | -20°C                                                                                                             | 120 hrs | Appearance<br>Without defect |           |
| 3   | High Temp. & High Humi. Storage | 40°C<br>90% RH                                                                                                    | 120 hrs | Appearance<br>Without defect |           |
| 4   | High Temp. Operating Display    | 50°C                                                                                                              | 120 hrs | Appearance<br>Without defect |           |
| 5   | Low Temp. Operating Display     | 0°C                                                                                                               | 120 hrs | Appearance<br>Without defect |           |
| 6   | Thermal Shock                   | 0°C, 30min. → 50°C, 30min.<br> |         | Appearance<br>Without defect | 10 cycles |

\*\* Dissipation current, contrast and display functions

\*\* Polarizing filter deterioration, other appearance defects

\*\* The function test shall be conducted after 4hours storage at the normal temperature and humidity after remove from the test chamber.





## 4. OPERATING INSTRUCTIONS

### 4.1 Input signal Function

| Pin No | Symbol              | I/O               | Function                                                                                                                                                                                                                                                                                                                                                                                                                                                                                     |               |                     |                   |    |    |     |    |    |  |    |    |  |    |    |     |    |    |  |    |    |  |    |    |   |    |    |   |
|--------|---------------------|-------------------|----------------------------------------------------------------------------------------------------------------------------------------------------------------------------------------------------------------------------------------------------------------------------------------------------------------------------------------------------------------------------------------------------------------------------------------------------------------------------------------------|---------------|---------------------|-------------------|----|----|-----|----|----|--|----|----|--|----|----|-----|----|----|--|----|----|--|----|----|---|----|----|---|
| 1~4    | NC                  | -                 | No Connection.                                                                                                                                                                                                                                                                                                                                                                                                                                                                               |               |                     |                   |    |    |     |    |    |  |    |    |  |    |    |     |    |    |  |    |    |  |    |    |   |    |    |   |
| 5      | V <sub>LCD</sub>    | PWR               | Main LCD power supply.                                                                                                                                                                                                                                                                                                                                                                                                                                                                       |               |                     |                   |    |    |     |    |    |  |    |    |  |    |    |     |    |    |  |    |    |  |    |    |   |    |    |   |
| 6      | V <sub>B0+</sub>    | PWR               | LCD Bias Voltages. These are the voltage sources to provide SEG driving currents. These voltages are generated internally. Connect capacitors of C <sub>BX</sub> value between V <sub>BX+</sub> and V <sub>BX-</sub> .                                                                                                                                                                                                                                                                       |               |                     |                   |    |    |     |    |    |  |    |    |  |    |    |     |    |    |  |    |    |  |    |    |   |    |    |   |
| 7      | V <sub>B0-</sub>    | PWR               |                                                                                                                                                                                                                                                                                                                                                                                                                                                                                              |               |                     |                   |    |    |     |    |    |  |    |    |  |    |    |     |    |    |  |    |    |  |    |    |   |    |    |   |
| 8      | V <sub>B1-</sub>    | PWR               |                                                                                                                                                                                                                                                                                                                                                                                                                                                                                              |               |                     |                   |    |    |     |    |    |  |    |    |  |    |    |     |    |    |  |    |    |  |    |    |   |    |    |   |
| 9      | V <sub>B1+</sub>    | PWR               |                                                                                                                                                                                                                                                                                                                                                                                                                                                                                              |               |                     |                   |    |    |     |    |    |  |    |    |  |    |    |     |    |    |  |    |    |  |    |    |   |    |    |   |
| 10     | V <sub>SS</sub>     | PWR               |                                                                                                                                                                                                                                                                                                                                                                                                                                                                                              | Power Ground. |                     |                   |    |    |     |    |    |  |    |    |  |    |    |     |    |    |  |    |    |  |    |    |   |    |    |   |
| 11     | V <sub>DD</sub>     | PWR               | Power supply terminal VCC.                                                                                                                                                                                                                                                                                                                                                                                                                                                                   |               |                     |                   |    |    |     |    |    |  |    |    |  |    |    |     |    |    |  |    |    |  |    |    |   |    |    |   |
| 12     | BM1                 | I                 | Bus mode: "HL": 8080 "HH": 6800<br>BM[1:0] "LH": S9 "LL": S8                                                                                                                                                                                                                                                                                                                                                                                                                                 |               |                     |                   |    |    |     |    |    |  |    |    |  |    |    |     |    |    |  |    |    |  |    |    |   |    |    |   |
| 13     | BM0                 | I                 |                                                                                                                                                                                                                                                                                                                                                                                                                                                                                              |               |                     |                   |    |    |     |    |    |  |    |    |  |    |    |     |    |    |  |    |    |  |    |    |   |    |    |   |
| 14     | DB7                 | I/O               | Bi-directional bus for both serial and parallel host interfaces. In serial modes, connect DB0 to SCK, DB3 to SDA.                                                                                                                                                                                                                                                                                                                                                                            |               |                     |                   |    |    |     |    |    |  |    |    |  |    |    |     |    |    |  |    |    |  |    |    |   |    |    |   |
| 15     | DB6                 | I/O               |                                                                                                                                                                                                                                                                                                                                                                                                                                                                                              |               |                     |                   |    |    |     |    |    |  |    |    |  |    |    |     |    |    |  |    |    |  |    |    |   |    |    |   |
| 16     | DB5                 | I/O               |                                                                                                                                                                                                                                                                                                                                                                                                                                                                                              |               |                     |                   |    |    |     |    |    |  |    |    |  |    |    |     |    |    |  |    |    |  |    |    |   |    |    |   |
| 17     | DB4                 | I/O               |                                                                                                                                                                                                                                                                                                                                                                                                                                                                                              |               |                     |                   |    |    |     |    |    |  |    |    |  |    |    |     |    |    |  |    |    |  |    |    |   |    |    |   |
| 18     | DB3/SDA             | I/O               |                                                                                                                                                                                                                                                                                                                                                                                                                                                                                              |               |                     |                   |    |    |     |    |    |  |    |    |  |    |    |     |    |    |  |    |    |  |    |    |   |    |    |   |
| 19     | DB2                 | I/O               |                                                                                                                                                                                                                                                                                                                                                                                                                                                                                              |               |                     |                   |    |    |     |    |    |  |    |    |  |    |    |     |    |    |  |    |    |  |    |    |   |    |    |   |
| 20     | DB1                 | I/O               |                                                                                                                                                                                                                                                                                                                                                                                                                                                                                              |               |                     |                   |    |    |     |    |    |  |    |    |  |    |    |     |    |    |  |    |    |  |    |    |   |    |    |   |
| 21     | DB0/SCK             | I/O               | <table border="1"> <thead> <tr> <th></th> <th>BM=1x<br/>(Parallel)</th> <th>BM=0x<br/>(Serial)</th> </tr> </thead> <tbody> <tr><td>D0</td><td>D0</td><td>SCK</td></tr> <tr><td>D1</td><td>D1</td><td></td></tr> <tr><td>D2</td><td>D2</td><td></td></tr> <tr><td>D3</td><td>D3</td><td>SDA</td></tr> <tr><td>D4</td><td>D4</td><td></td></tr> <tr><td>D5</td><td>D5</td><td></td></tr> <tr><td>D6</td><td>D6</td><td>-</td></tr> <tr><td>D7</td><td>D7</td><td>-</td></tr> </tbody> </table> |               | BM=1x<br>(Parallel) | BM=0x<br>(Serial) | D0 | D0 | SCK | D1 | D1 |  | D2 | D2 |  | D3 | D3 | SDA | D4 | D4 |  | D5 | D5 |  | D6 | D6 | - | D7 | D7 | - |
|        | BM=1x<br>(Parallel) | BM=0x<br>(Serial) |                                                                                                                                                                                                                                                                                                                                                                                                                                                                                              |               |                     |                   |    |    |     |    |    |  |    |    |  |    |    |     |    |    |  |    |    |  |    |    |   |    |    |   |
| D0     | D0                  | SCK               |                                                                                                                                                                                                                                                                                                                                                                                                                                                                                              |               |                     |                   |    |    |     |    |    |  |    |    |  |    |    |     |    |    |  |    |    |  |    |    |   |    |    |   |
| D1     | D1                  |                   |                                                                                                                                                                                                                                                                                                                                                                                                                                                                                              |               |                     |                   |    |    |     |    |    |  |    |    |  |    |    |     |    |    |  |    |    |  |    |    |   |    |    |   |
| D2     | D2                  |                   |                                                                                                                                                                                                                                                                                                                                                                                                                                                                                              |               |                     |                   |    |    |     |    |    |  |    |    |  |    |    |     |    |    |  |    |    |  |    |    |   |    |    |   |
| D3     | D3                  | SDA               |                                                                                                                                                                                                                                                                                                                                                                                                                                                                                              |               |                     |                   |    |    |     |    |    |  |    |    |  |    |    |     |    |    |  |    |    |  |    |    |   |    |    |   |
| D4     | D4                  |                   |                                                                                                                                                                                                                                                                                                                                                                                                                                                                                              |               |                     |                   |    |    |     |    |    |  |    |    |  |    |    |     |    |    |  |    |    |  |    |    |   |    |    |   |
| D5     | D5                  |                   |                                                                                                                                                                                                                                                                                                                                                                                                                                                                                              |               |                     |                   |    |    |     |    |    |  |    |    |  |    |    |     |    |    |  |    |    |  |    |    |   |    |    |   |
| D6     | D6                  | -                 |                                                                                                                                                                                                                                                                                                                                                                                                                                                                                              |               |                     |                   |    |    |     |    |    |  |    |    |  |    |    |     |    |    |  |    |    |  |    |    |   |    |    |   |
| D7     | D7                  | -                 |                                                                                                                                                                                                                                                                                                                                                                                                                                                                                              |               |                     |                   |    |    |     |    |    |  |    |    |  |    |    |     |    |    |  |    |    |  |    |    |   |    |    |   |
| 22     | WR1                 | I                 | WR [1:0] controls the read/write operation of the host interface. See Host Interface section for details. The meaning of WR [1:0] depends on whether the interface is in the 6800 mode, or the 8080 mode. In serial modes, these two pins are not used and can be connected to V <sub>ss</sub> .                                                                                                                                                                                             |               |                     |                   |    |    |     |    |    |  |    |    |  |    |    |     |    |    |  |    |    |  |    |    |   |    |    |   |
| 23     | WR0                 | I                 |                                                                                                                                                                                                                                                                                                                                                                                                                                                                                              |               |                     |                   |    |    |     |    |    |  |    |    |  |    |    |     |    |    |  |    |    |  |    |    |   |    |    |   |
| 24     | CD                  | I                 | Select the incoming command if it is a control instruction or for display data. CD pin is not used in S9 mode, connect it to V <sub>dd</sub> or V <sub>ss</sub> .<br>"L": control instruction "H": display data                                                                                                                                                                                                                                                                              |               |                     |                   |    |    |     |    |    |  |    |    |  |    |    |     |    |    |  |    |    |  |    |    |   |    |    |   |
| 25     | RST                 | I                 | When RST="L", all control registers are re-initialized by their default states.                                                                                                                                                                                                                                                                                                                                                                                                              |               |                     |                   |    |    |     |    |    |  |    |    |  |    |    |     |    |    |  |    |    |  |    |    |   |    |    |   |
| 26     | /CS0                | I                 | Chip Select or Chip Address. In parallel mode and S8 mode, chip is selected when /CS0="L". When the chip is not selected, DB[7:0] will be high impedance.                                                                                                                                                                                                                                                                                                                                    |               |                     |                   |    |    |     |    |    |  |    |    |  |    |    |     |    |    |  |    |    |  |    |    |   |    |    |   |
| 27~30  | NC                  | -                 | No Connection.                                                                                                                                                                                                                                                                                                                                                                                                                                                                               |               |                     |                   |    |    |     |    |    |  |    |    |  |    |    |     |    |    |  |    |    |  |    |    |   |    |    |   |

| Bus Type            |         | 8080                   | 6800                     | SPI (S8) | SPI (S9)       |  |
|---------------------|---------|------------------------|--------------------------|----------|----------------|--|
| Control & Data Pins | BM[1:0] | 10b                    | 11b                      | 00b      | 01b            |  |
|                     | CS[1:0] | Chip Select            |                          |          |                |  |
|                     | CD      | Control/Data           |                          |          |                |  |
|                     | WR0     | $\overline{\text{WR}}$ | R/ $\overline{\text{W}}$ | -        |                |  |
|                     | WR1     | $\overline{\text{RD}}$ | EN                       | -        |                |  |
|                     | Access  | Read/Write             |                          |          | Write Only     |  |
|                     | D[7:0]  | 8-bit bus (Tri-state)  |                          |          | D0=SCK, D3=SDA |  |

\* Connect unused control pins and data bus pins to V<sub>DD</sub> or V<sub>SS</sub>



## 4.2 Voltage Generator Circuit

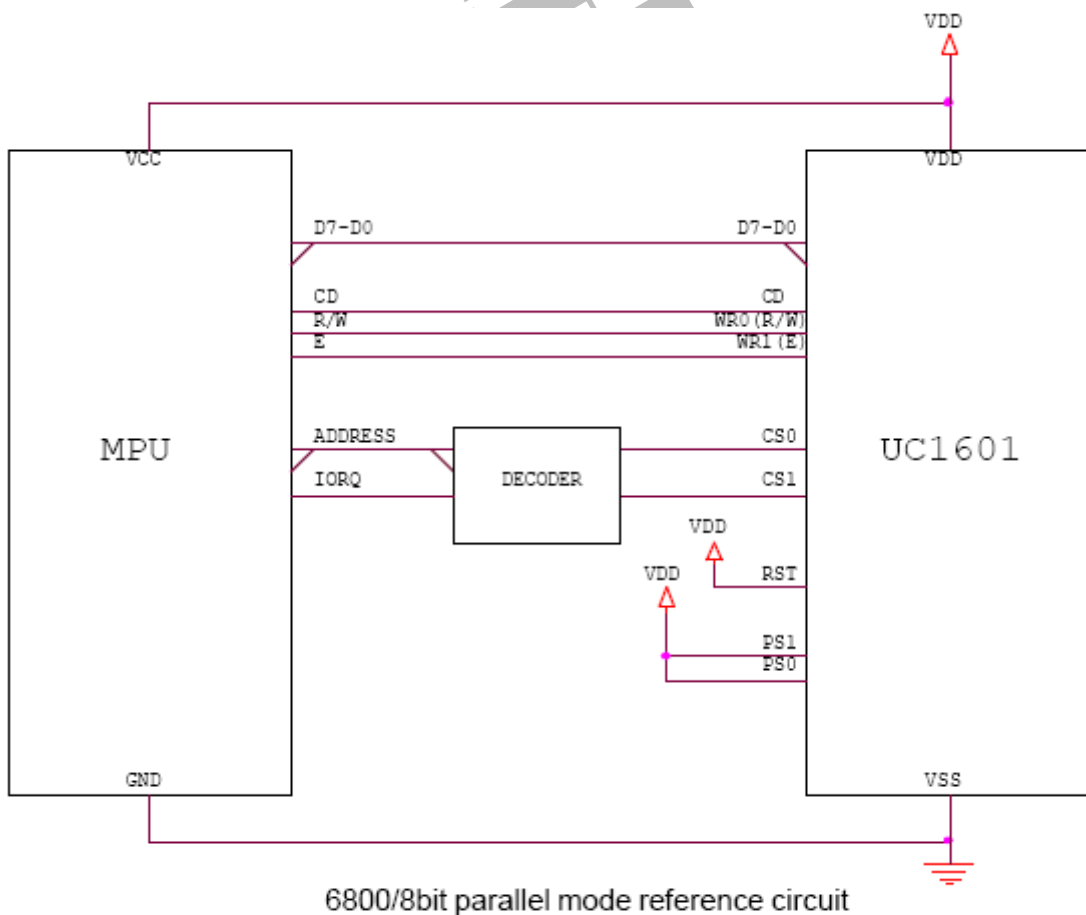
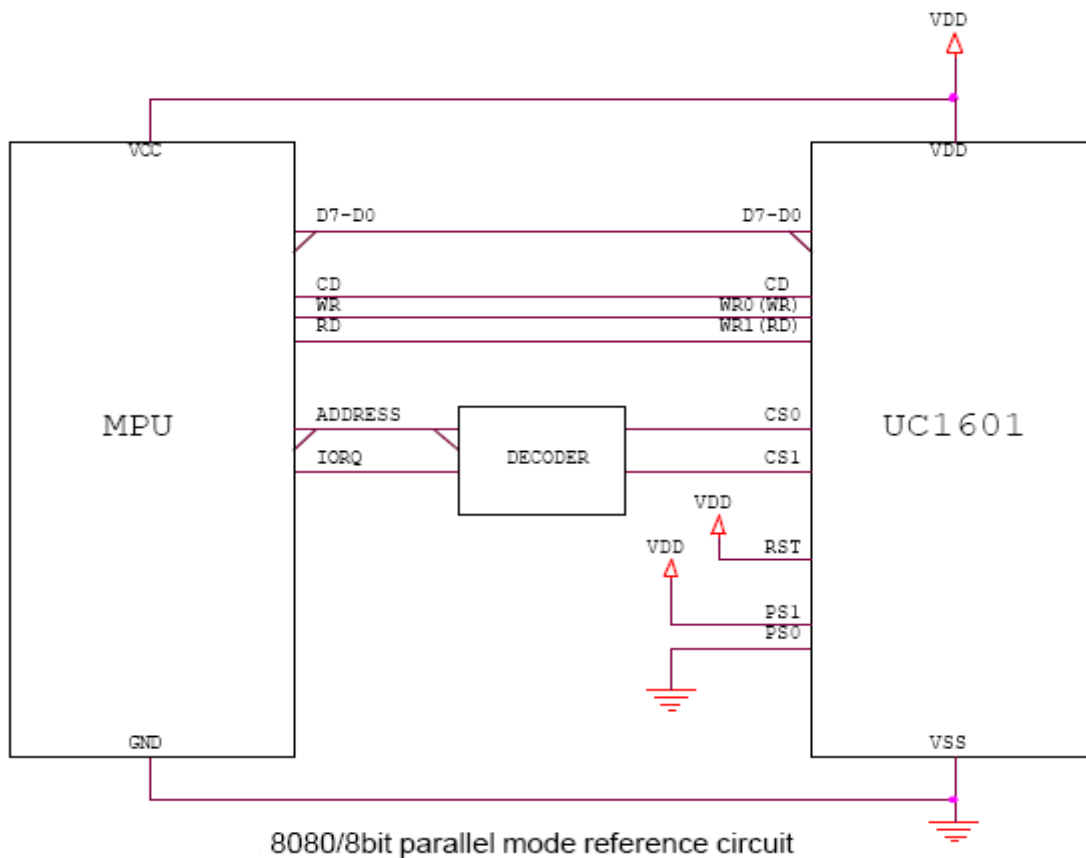

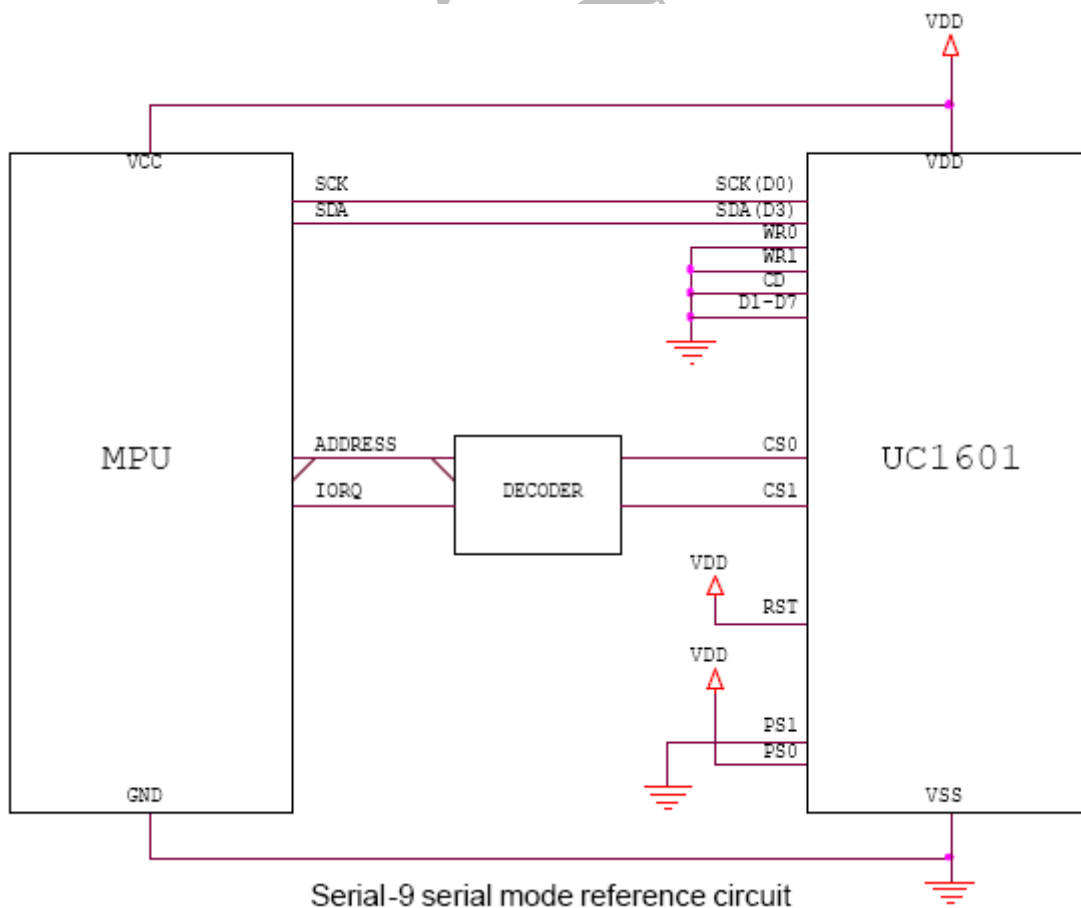
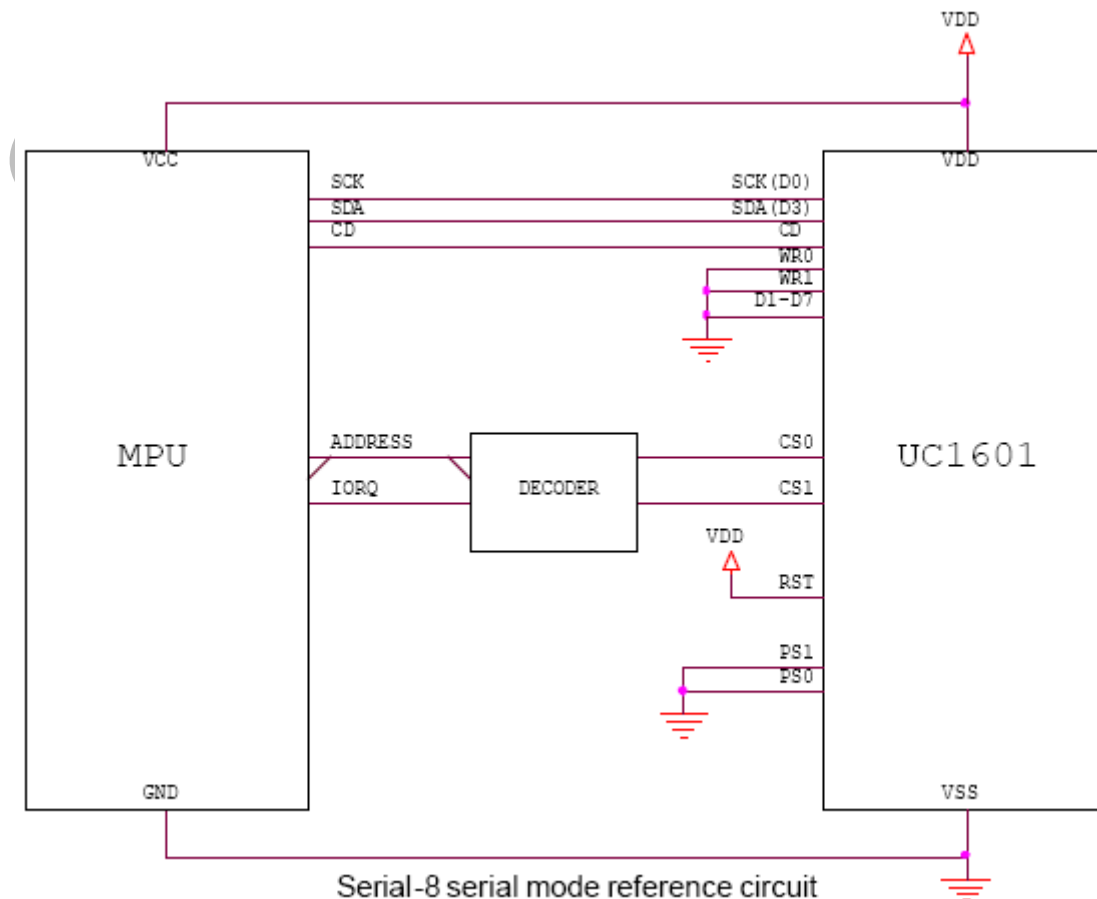

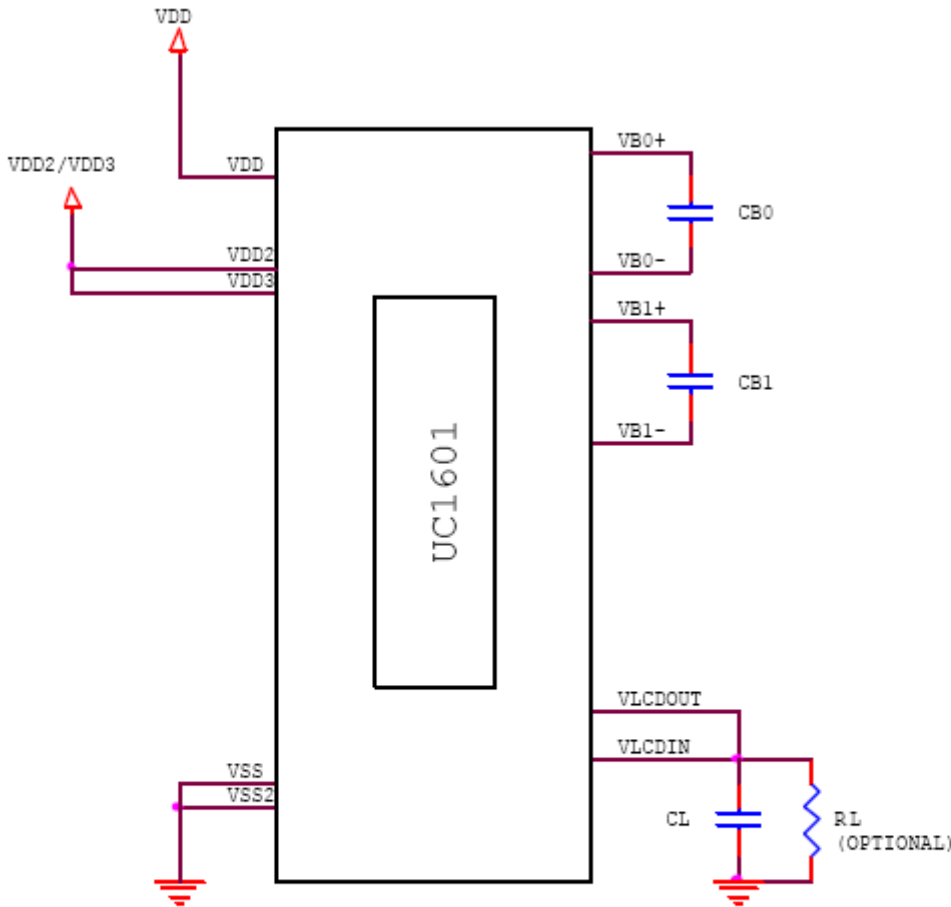

**Note**

- Recommended component values:
  - $C_B$ : 100x~200x LCD load capacitance or 1.0uF (2V), whichever is higher.
  - $C_L$ : 10nF ~ 30nF (25V) is appropriate for most applications.
  - $R_L$ : 10M $\Omega$ . Acts as a draining circuit when the power is abnormally shut down.

FOR FREE



### 4.3 Timing Diagram

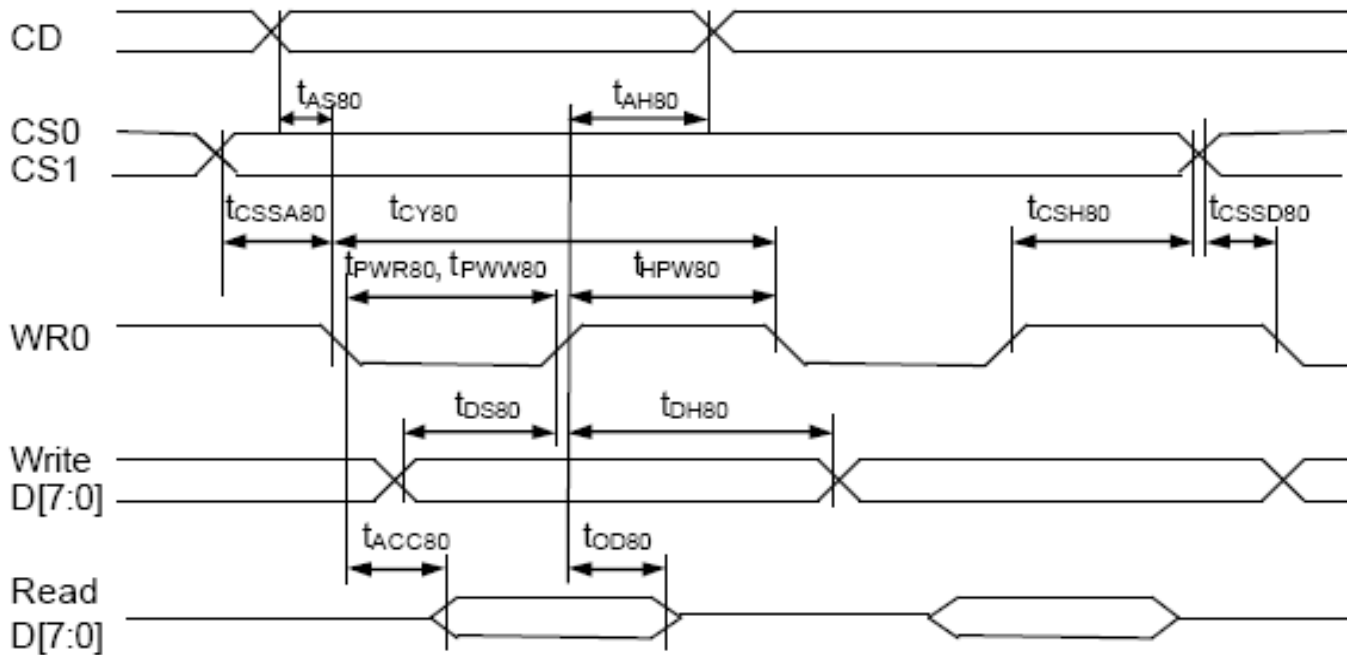

Parallel Bus Timing Characteristics (for 8080 MCU)

( $2.5V \leq V_{DD} < 3.3V$ ,  $T_a = -30$  to  $+85^\circ C$ )

| Symbol       | Signal   | Description            | Condition     | Min. | Max. | Units |
|--------------|----------|------------------------|---------------|------|------|-------|
| $t_{AS80}$   | CD       | Address setup time     |               | 0    | -    | nS    |
| $t_{AH80}$   |          | Address hold time      |               | 40   | -    | nS    |
| $t_{CY80}$   |          | System cycle time      |               | 135  | -    | nS    |
| $t_{PWR80}$  | WR1      | Pulse width (read)     |               | 65   | -    | nS    |
| $t_{PWW80}$  | WR0      | Pulse width (write)    |               | 65   | -    | nS    |
| $t_{HPW80}$  | WR0, WR1 | High pulse width       |               | 65   | -    | nS    |
| $t_{DS80}$   | D0~D7    | Data setup time        |               | 30   | -    | nS    |
| $t_{DH80}$   |          | Data hold time         |               | 20   | -    | nS    |
| $t_{ACC80}$  |          | Read access time       | $C_L = 100pF$ | -    | 50   | nS    |
| $t_{OD80}$   |          | Output disable time    |               | 10   | 50   | nS    |
| $t_{CSSA80}$ | CS1/CS0  | Chip select setup time |               | 10   |      | nS    |
| $t_{CSSD80}$ |          |                        |               | 10   |      | nS    |
| $t_{CSH80}$  |          |                        |               | 20   |      | nS    |

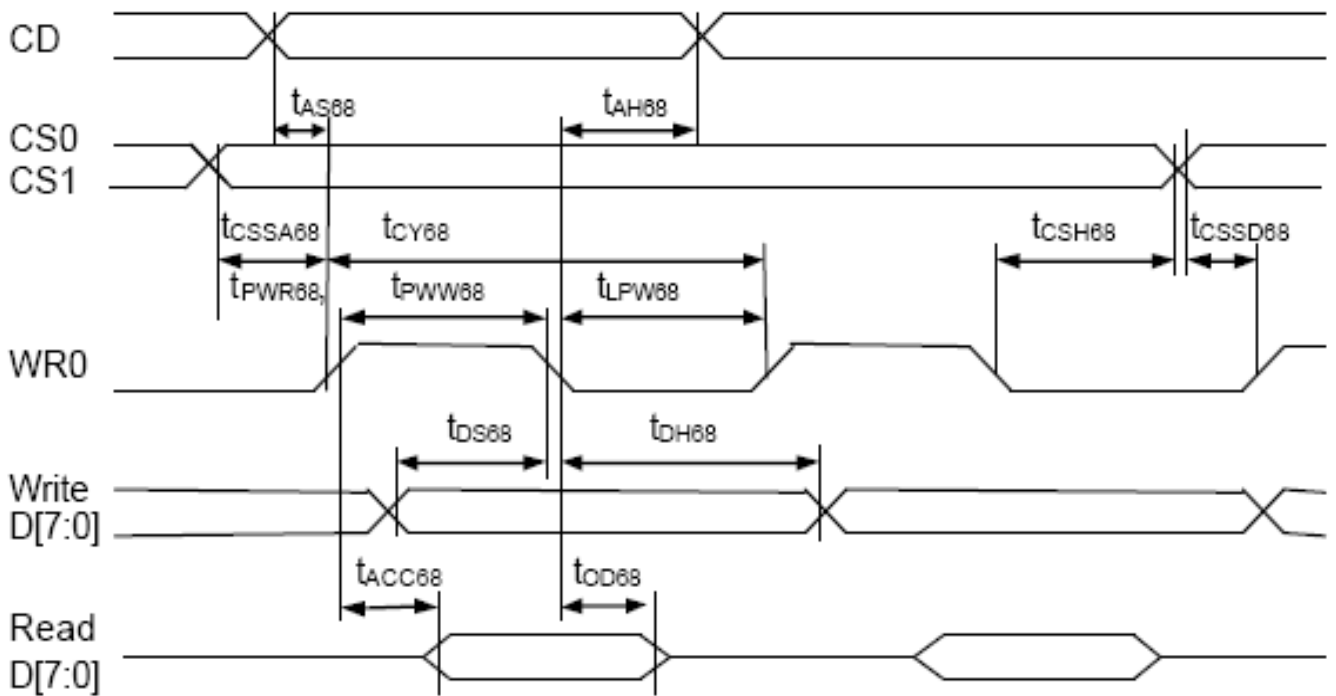

Parallel Bus Timing Characteristics (for 6800 MCU)

( $2.5V \leq V_{DD} < 3.3V$ ,  $T_a = -30$  to  $+85^\circ C$ )

| Symbol       | Signal  | Description            | Condition     | Min. | Max. | Units |
|--------------|---------|------------------------|---------------|------|------|-------|
| $t_{AS88}$   | CD      | Address setup time     |               | 0    | -    | nS    |
| $t_{AH88}$   |         | Address hold time      |               | 40   |      |       |
| $t_{CY88}$   |         | System cycle time      |               | 135  | -    | nS    |
| $t_{PWR88}$  | WR1     | Pulse width (read)     |               | 65   | -    | nS    |
| $t_{PWW88}$  |         | Pulse width (write)    |               | 65   | -    | nS    |
| $t_{LPW88}$  |         | Low pulse width        |               | 65   | -    | nS    |
| $t_{DS88}$   | D0~D7   | Data setup time        |               | 30   | -    | nS    |
| $t_{DH88}$   |         | Data hold time         |               | 15   |      |       |
| $t_{ACC88}$  |         | Read access time       | $C_L = 100pF$ | -    | 50   | nS    |
| $t_{OD88}$   |         | Output disable time    |               | 10   | 50   |       |
| $T_{CSSA88}$ | CS1/CS0 | Chip select setup time |               | 10   |      | nS    |
| $T_{CSSD88}$ |         |                        |               | 10   |      |       |
| $T_{CSH88}$  |         |                        |               | 20   |      |       |

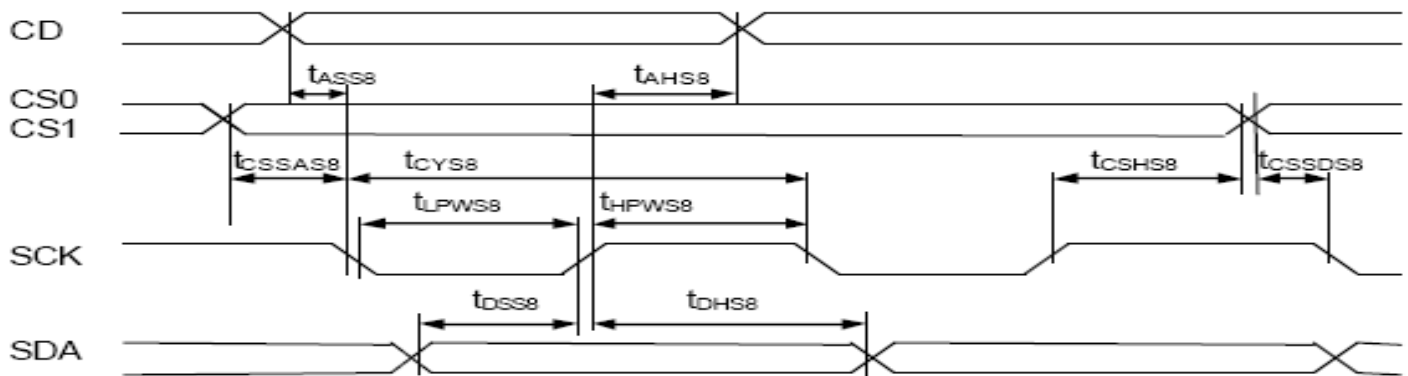

Serial Bus Timing Characteristics (for S8)

( $2.5V \leq V_{DD} < 3.3V$ ,  $T_a = -30$  to  $+85^\circ C$ )

| Symbol                                      | Signal  | Description            | Condition | Min.           | Max. | Units |
|---------------------------------------------|---------|------------------------|-----------|----------------|------|-------|
| $t_{ASS8}$                                  | CD      | Address setup time     |           | 0              | -    | nS    |
| $t_{AHS8}$                                  |         | Address hold time      |           | 40             | -    | nS    |
| $t_{CYS8}$                                  | SCK     | System cycle time      |           | 135            | -    | nS    |
| $t_{LPWS8}$                                 |         | Low pulse width        |           | 65             | -    | nS    |
| $t_{HPWS8}$                                 |         | High pulse width       |           | 65             | -    | nS    |
| $t_{DSS8}$                                  | SDA     | Data setup time        |           | 30             | -    | nS    |
| $t_{DHS8}$                                  |         | Data hold time         |           | 15             | -    | nS    |
| $t_{CSSAS8}$<br>$t_{CSSDS8}$<br>$t_{CSHS8}$ | CS1/CS0 | Chip select setup time |           | 10<br>10<br>20 |      | nS    |

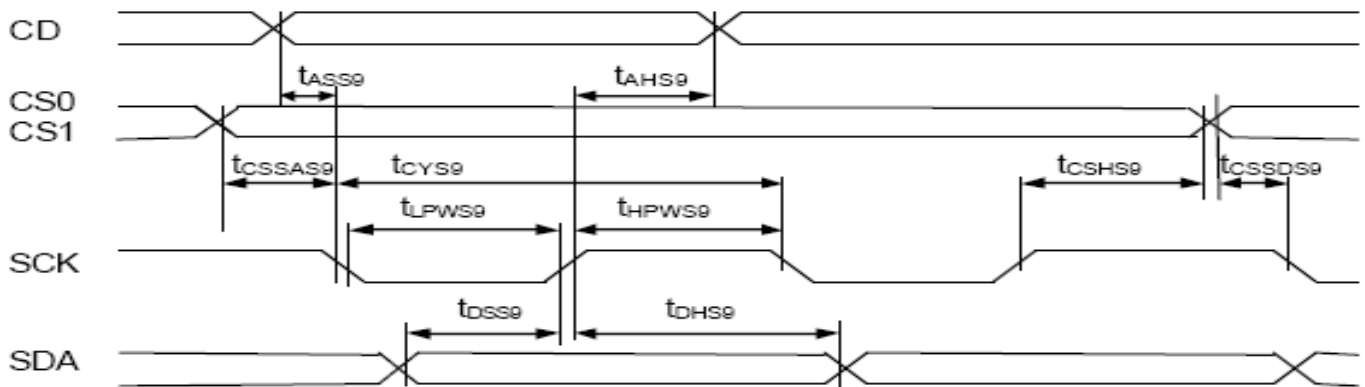

Serial Bus Timing Characteristics (for S9)

( $2.5V \leq V_{DD} < 3.3V$ ,  $T_a = -30$  to  $+85^\circ C$ )

| Symbol                                      | Signal  | Description            | Condition | Min.           | Max. | Units |
|---------------------------------------------|---------|------------------------|-----------|----------------|------|-------|
| $t_{ASS9}$                                  | CD      | Address setup time     |           | 0              | -    | nS    |
| $t_{AHS9}$                                  |         | Address hold time      |           | 40             | -    | nS    |
| $t_{CYS9}$                                  | SCK     | System cycle time      |           | 135            | -    | nS    |
| $t_{LPWS9}$                                 |         | Low pulse width        |           | 65             | -    | nS    |
| $t_{HPWS9}$                                 |         | High pulse width       |           | 65             | -    | nS    |
| $t_{DSS9}$                                  | SDA     | Data setup time        |           | 30             | -    | nS    |
| $t_{DHS9}$                                  |         | Data hold time         |           | 15             | -    | nS    |
| $t_{CSSAS9}$<br>$t_{CSSDS9}$<br>$t_{CSHS9}$ | CS1/CS0 | Chip select setup time |           | 10<br>10<br>20 |      | nS    |



## 5. NOTES

### ▪ Safety

- If the LCD panel breaks, be careful not to get the liquid crystal in your mouth. If the liquid crystal touches your skin or clothes, wash it off immediately using soap and plenty of water.

### Handling

- Avoid static electricity as this can damage the CMOS LSI.
- The LCD panel is plate glass; do not hit or crush it.
- Do not remove the panel or frame from the module.
- The polarizing plate of the display is very fragile; handle it very carefully

### Mounting and Design

- Mount the module by using the specified mounting part and holes.
- To protect the module from external pressure, leave a small gap by placing transparent plates (e.g. acrylic or glass ) on the display surface, frame, and polarizing plate
- Design the system so that no input signal is given unless the power-supply voltage is applied.
- Keep the module dry. Avoid condensation, otherwise the transparent electrodes may break.

### Storage

- Store the module in a dark place where the temperature is  $25\text{ }^{\circ}\text{C}\pm 10\text{ }^{\circ}\text{C}$  and the humidity below 65% RH.
- Do not store the module near organic solvents or corrosive gases.
- Do not crush, shake, or jolt the module (including accessories).

### Cleaning

- Do not wipe the polarizing plate with a dry cloth, as it may scratch the surface.
- Wipe the module gently with soft cloth soaked with a petroleum benzine.
- Do not use ketonic solvents (ketone and acetone) or aromatic solvents (toluene and xylene), as they may damage the polarizing plate.

## 6. OPERATION PRECAUTIONS

Any changes that need to be made in this specification or any problems arising from it will be dealt with quickly by discussion between both companies.

Quality warranty period: Within one year after shipment date (excluding abnormal usage way and abnormal environments.)





## 7. LCM Dimension

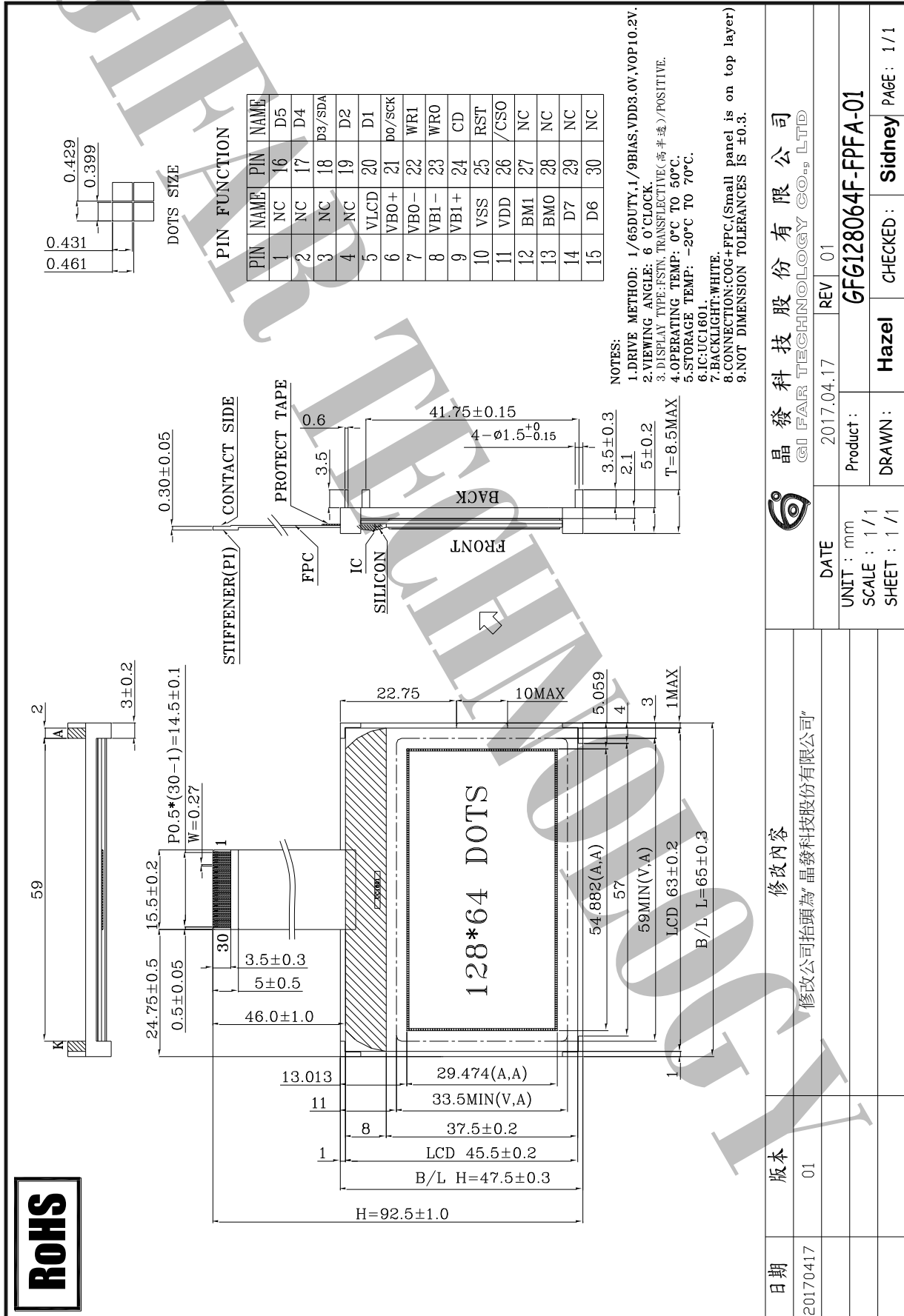



## 8. PACKAGE INFORMATION

|   |                      |   |                       |
|---|----------------------|---|-----------------------|
| 1 | 1 Tray               | : | 15 pcs (modules)      |
| 2 | 1 stack              | : | 10 tray +1 Cover tray |
| 3 | 1 Carton             | : | 2 stack               |
| 4 | Total pcs            | : | 1 Carton = 300 pcs    |
| 5 | Carton size = NO. 17 | : | 495*315*435mm         |
| 6 | Net weight           | : | TBD KG                |
| 7 | Gross weight         | : | TBD KG                |

\*\* Packaging information \*\*

- 1 Tray = 15 pcs

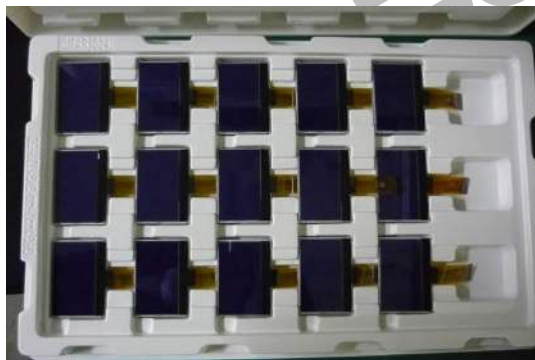

- 1 stack=10 tray+1 Cover tray

\*\*Each layer of tray should be staggered stacked



- 1 Carton = 2 stack Total pcs = 300 pcs



出貨檢驗標準書  
Shipping inspection standard

| 核准<br>Approved by | 審核<br>Checked by | 作成<br>Made by |
|-------------------|------------------|---------------|
| ANDY              | JACKY            | RUBY          |

**1.目的 Purpose :**

規範出貨產品之檢驗項目及判斷標準，確保產品出貨能滿足客戶要求。

Standardize the inspection items and judgment standards to ensure the products that shipped out can meet customer's requirements.

**2.範圍 Area :**

適用於出廠之所有產品。

Applicable to all products shipped from the factory.

**3.名詞解釋 Explanation of terms :**

3-1 主要缺陷：亦會造成功能缺失或嚴重外觀缺陷。

Major Defects: It also causes loss of function or serious appearance defects.

3-2 次要缺陷：稍有缺陷但不影響客戶使用。

Minor defect: Slightly defective but does not affect customer use.

**4.檢驗體制 Inspection system :**

4-1 抽樣計劃：依 ANSI/ASQ Z1.4 一般檢驗水準 II 之 正常檢驗一次抽驗方案。

Sampling plan: According to ANSI/ASQ Z1.4 general inspection level II the normal inspection one-time sampling plan.

4-2 允收水準 Acceptable Level : (AQL)

主要缺陷 Major defect : 0.4 %

次要缺陷 Minor defect : 0.65 %

**5.檢驗條件 Inspection conditions :**

5-1 使用相關之檢測儀器及測試、量測工具。

Use relevant testing instrument, testing and measuring tools .

5-2 環境要求：其條件需控制在常溫下  $23^{\circ}\text{C}\pm 3^{\circ}\text{C}$  及溼度 70%RH 以下。

Environmental requirements: The conditions should be controlled at room temperature  $23^{\circ}\text{C}\pm 3^{\circ}\text{C}$  and humidity below 70%RH.

5-3 外觀檢驗：須在  $380\pm 20\%$  LUX 的白色日光燈下，其目視距離需於產品離  $30\pm 5$  cm 檢驗。

Appearance inspection: Under the white fluorescent lamp of  $380\pm 20\%$  LUX , the visual distance shall be checked above the product  $30 \pm 5$  cm.

5-4 電性測試 Electrical Testing :

5-4-1 有背光之產品需關燈並在  $5\sim 300\text{Lux}\pm 3\%$  下檢驗。

The products with backlight should be tested at  $5\sim 300\pm 3\%$  Lux.

5-4-2 無背光之產品需開燈並在  $60\sim 300\text{Lux}\pm 3\%$  白色日光燈下檢驗。

Products without backlight need to be turned on and tested under  $60\sim 300 \pm 3\%$  LUX white fluorescent lamps .

5-5 檢查視角依產品視角方向。

Check the viewing angle according to the product viewing angle.

5-6 其不良現象檢視區域 Bad phenomenon View area

5-6-1 適用種類 Applicable category : COB、TFT

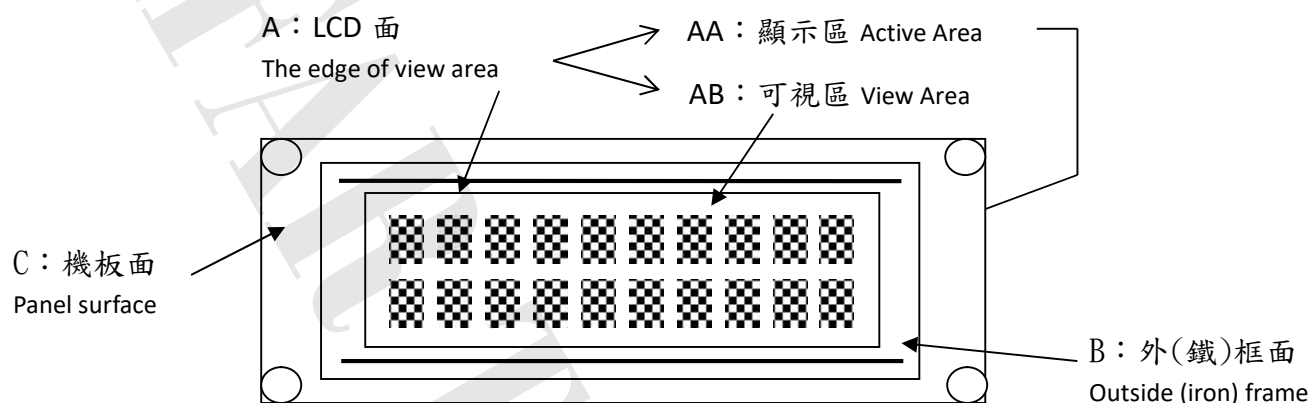

5-6-2 適用種類 Applicable category : COG、TAB、TN

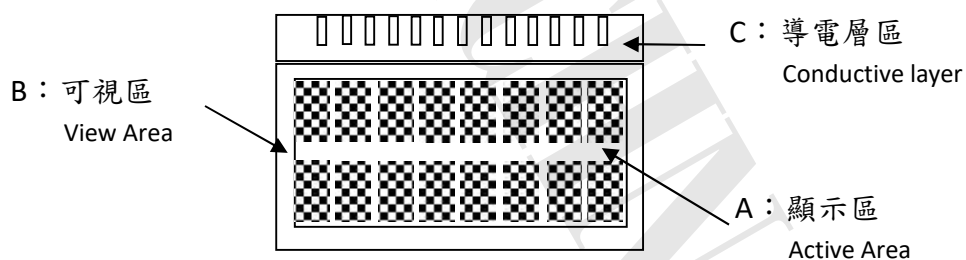

| 種類 Category |                          | COG                                                                                                                                                                                                                                                                                      |                                                                                                                                                                                                                                                                                                                                                                                                                                                                                           |        |         |                       |                         |               |           |            |               |   |            |               |   |         |            |   |        |                  |                         |
|-------------|--------------------------|------------------------------------------------------------------------------------------------------------------------------------------------------------------------------------------------------------------------------------------------------------------------------------------|-------------------------------------------------------------------------------------------------------------------------------------------------------------------------------------------------------------------------------------------------------------------------------------------------------------------------------------------------------------------------------------------------------------------------------------------------------------------------------------------|--------|---------|-----------------------|-------------------------|---------------|-----------|------------|---------------|---|------------|---------------|---|---------|------------|---|--------|------------------|-------------------------|
| 編號 No.      | 檢驗項目 Item                | 檢驗內容及判定標準<br>Inspection Content & Standard                                                                                                                                                                                                                                               |                                                                                                                                                                                                                                                                                                                                                                                                                                                                                           |        | 區域 Zone | 類別 Category           | 缺陷等級 Level              |               |           |            |               |   |            |               |   |         |            |   |        |                  |                         |
| 1           | 點類(一)<br>Dot(1)          | 黑點、刺傷...等圓狀<br>Black dot、Stab...and other round shape<br>$\phi = \frac{(X + Y)}{2}$                                                                                                                     | 兩點距離須超過 5 mm<br>Two points have to be $\geq 5$ mm                                                                                                                                                                                                                                                                                                                                                                                                                                         |        | A<br>B  | 外觀<br>Appearance      | 次要<br>Minor<br>AQL0.65% |               |           |            |               |   |            |               |   |         |            |   |        |                  |                         |
|             |                          | $\phi$ (mm)                                                                                                                                                                                                                                                                              | 允收數<br>Acceptance Qty                                                                                                                                                                                                                                                                                                                                                                                                                                                                     |        |         |                       |                         |               |           |            |               |   |            |               |   |         |            |   |        |                  |                         |
|             |                          | $\phi \leq 0.1$                                                                                                                                                                                                                                                                          | 無視 Ignore                                                                                                                                                                                                                                                                                                                                                                                                                                                                                 |        |         |                       |                         |               |           |            |               |   |            |               |   |         |            |   |        |                  |                         |
|             |                          | $0.1 < \phi \leq 0.25$                                                                                                                                                                                                                                                                   | 3                                                                                                                                                                                                                                                                                                                                                                                                                                                                                         |        |         |                       |                         |               |           |            |               |   |            |               |   |         |            |   |        |                  |                         |
|             |                          | $0.25 < \phi \leq 0.3$                                                                                                                                                                                                                                                                   | 1                                                                                                                                                                                                                                                                                                                                                                                                                                                                                         |        |         |                       |                         |               |           |            |               |   |            |               |   |         |            |   |        |                  |                         |
|             |                          | $\phi > 0.3$                                                                                                                                                                                                                                                                             | 0                                                                                                                                                                                                                                                                                                                                                                                                                                                                                         |        |         |                       |                         |               |           |            |               |   |            |               |   |         |            |   |        |                  |                         |
| 2           | 點類(二)<br>Dot(2)          | 氣泡、凹凸點<br>Bubble、Uneven dots<br>$\phi = \frac{(X + Y)}{2}$                                                                                                                                            | 兩點距離須超過 5 mm<br>Two points have to be $\geq 5$ mm                                                                                                                                                                                                                                                                                                                                                                                                                                         |        | A<br>B  | 外觀<br>Appearance      | 次要<br>Minor<br>AQL0.65% |               |           |            |               |   |            |               |   |         |            |   |        |                  |                         |
|             |                          | $\phi$ (mm)                                                                                                                                                                                                                                                                              | 允收數<br>Acceptance Qty                                                                                                                                                                                                                                                                                                                                                                                                                                                                     |        |         |                       |                         |               |           |            |               |   |            |               |   |         |            |   |        |                  |                         |
|             |                          | $\phi \leq 0.2$                                                                                                                                                                                                                                                                          | 無視 Ignore                                                                                                                                                                                                                                                                                                                                                                                                                                                                                 |        |         |                       |                         |               |           |            |               |   |            |               |   |         |            |   |        |                  |                         |
|             |                          | $0.2 < \phi \leq 0.5$                                                                                                                                                                                                                                                                    | 2                                                                                                                                                                                                                                                                                                                                                                                                                                                                                         |        |         |                       |                         |               |           |            |               |   |            |               |   |         |            |   |        |                  |                         |
|             |                          | $\phi > 0.5$                                                                                                                                                                                                                                                                             | 0                                                                                                                                                                                                                                                                                                                                                                                                                                                                                         |        |         |                       |                         |               |           |            |               |   |            |               |   |         |            |   |        |                  |                         |
| 3           | 線類<br>Line               | 刮傷、毛屑...等線狀<br>Scratch、Fiber.. and other linear shape.<br>                                                                                                                                            | <table border="1"> <thead> <tr> <th>L (mm)</th> <th>W (mm)</th> <th>允收數<br/>Acceptance Qty</th> </tr> </thead> <tbody> <tr> <td>--</td> <td><math>W \leq 0.02</math></td> <td>無視 Ignore</td> </tr> <tr> <td><math>L \leq 5</math></td> <td><math>W \leq 0.03</math></td> <td>3</td> </tr> <tr> <td><math>L \leq 3</math></td> <td><math>W \leq 0.05</math></td> <td>2</td> </tr> <tr> <td><math>L &gt; 5</math></td> <td><math>W &gt; 0.05</math></td> <td>0</td> </tr> </tbody> </table> | L (mm) | W (mm)  | 允收數<br>Acceptance Qty | --                      | $W \leq 0.02$ | 無視 Ignore | $L \leq 5$ | $W \leq 0.03$ | 3 | $L \leq 3$ | $W \leq 0.05$ | 2 | $L > 5$ | $W > 0.05$ | 0 | A<br>B | 外觀<br>Appearance | 次要<br>Minor<br>AQL0.65% |
| L (mm)      | W (mm)                   | 允收數<br>Acceptance Qty                                                                                                                                                                                                                                                                    |                                                                                                                                                                                                                                                                                                                                                                                                                                                                                           |        |         |                       |                         |               |           |            |               |   |            |               |   |         |            |   |        |                  |                         |
| --          | $W \leq 0.02$            | 無視 Ignore                                                                                                                                                                                                                                                                                |                                                                                                                                                                                                                                                                                                                                                                                                                                                                                           |        |         |                       |                         |               |           |            |               |   |            |               |   |         |            |   |        |                  |                         |
| $L \leq 5$  | $W \leq 0.03$            | 3                                                                                                                                                                                                                                                                                        |                                                                                                                                                                                                                                                                                                                                                                                                                                                                                           |        |         |                       |                         |               |           |            |               |   |            |               |   |         |            |   |        |                  |                         |
| $L \leq 3$  | $W \leq 0.05$            | 2                                                                                                                                                                                                                                                                                        |                                                                                                                                                                                                                                                                                                                                                                                                                                                                                           |        |         |                       |                         |               |           |            |               |   |            |               |   |         |            |   |        |                  |                         |
| $L > 5$     | $W > 0.05$               | 0                                                                                                                                                                                                                                                                                        |                                                                                                                                                                                                                                                                                                                                                                                                                                                                                           |        |         |                       |                         |               |           |            |               |   |            |               |   |         |            |   |        |                  |                         |
|             |                          |                                                                                                                                                                                                                                                                                          |                                                                                                                                                                                                                                                                                                                                                                                                                                                                                           |        |         |                       |                         |               |           |            |               |   |            |               |   |         |            |   |        |                  |                         |
|             |                          |                                                                                                                                                                                                                                                                                          |                                                                                                                                                                                                                                                                                                                                                                                                                                                                                           |        |         |                       |                         |               |           |            |               |   |            |               |   |         |            |   |        |                  |                         |
|             |                          |                                                                                                                                                                                                                                                                                          |                                                                                                                                                                                                                                                                                                                                                                                                                                                                                           |        |         |                       |                         |               |           |            |               |   |            |               |   |         |            |   |        |                  |                         |
|             |                          |                                                                                                                                                                                                                                                                                          |                                                                                                                                                                                                                                                                                                                                                                                                                                                                                           |        |         |                       |                         |               |           |            |               |   |            |               |   |         |            |   |        |                  |                         |
| 4           | 底色<br>Background color   | 同批供貨不能有明顯色差<br>No obvious color difference allowed in same shipment.<br>(必要時與客端制定限度樣)<br>(According to the gold samples if necessary)                                                                                                                                                    |                                                                                                                                                                                                                                                                                                                                                                                                                                                                                           |        | B       | 外觀<br>Appearance      | 次要<br>Minor<br>AQL0.65% |               |           |            |               |   |            |               |   |         |            |   |        |                  |                         |
| 5           | FPC 外觀<br>FPC Appearance | ※ FPC 上刺傷導致線路無法導通 拒收<br>Stabbing on the FPC causes the line to fail to conduct<br>Reject<br>※ FPC 上髒污或是殘留異物以致線路無法導通 拒收<br>Dirty or residual foreign matter on the FPC makes the circuit unable to conduct<br>Reject<br>※ FPC 直角折痕、斷裂 拒收<br>FPC right-angle crease and fracture<br>Reject |                                                                                                                                                                                                                                                                                                                                                                                                                                                                                           |        | C       | 外觀<br>Appearance      | 主要<br>Major<br>AQL 0.4% |               |           |            |               |   |            |               |   |         |            |   |        |                  |                         |

|    |                             |                                                                                                                                                                                                                                                                |   |                   |                         |
|----|-----------------------------|----------------------------------------------------------------------------------------------------------------------------------------------------------------------------------------------------------------------------------------------------------------|---|-------------------|-------------------------|
| 6  | 點、線類<br>(三)<br>Dot、Line (3) | ※ 於全黑、白畫面下看見之區塊狀或線狀不良 拒收<br>There is a block or linear in the view area under the screen is whole black or white.<br>Reject<br>※ 但依 2% ND Filter 遮蓋無視 允收<br>But after inspecting by 2% ND Filter without seeing block or linear, it is confirmed<br>Acceptance | A | 電訊<br>Electronics | 次要<br>Minor<br>AQL0.65% |
| 7  | 點、線類<br>(四)<br>Dot、Line (4) | 畫面中顯示出現黑、白、亮、異色點或線狀<br>There is a black, white, bright or other dot or lines showing in the view area.<br>※ 依編號 1、3 之判定標準<br>According to the inspection standard: No. 1 and 3.                                                                                | A | 電訊<br>Electronics | 次要<br>Minor<br>AQL0.65% |
| 8  | 缺字<br>Lack of<br>characters | 顯示時畫面缺少部份字元 拒收<br>Lacking part of characters in the view area.<br>Reject                                                                                                                                                                                       | A | 電訊<br>Electronics | 主要<br>Major<br>AQL 0.4% |
| 9  | 無動作<br>No reaction          | 顯示畫面一直處於起始畫面而無法進行切換 拒收<br>The display (view area) always show in the initial screen and can't be switched to others.<br>Reject                                                                                                                                 | A | 電訊<br>Electronics | 主要<br>Major<br>AQL 0.4% |
| 10 | 無畫面<br>No display           | 通電後，完全無任何畫面顯示 拒收<br>After connecting to the power, there is no image.<br>Reject                                                                                                                                                                                | A | 電訊<br>Electronics | 主要<br>Major<br>AQL 0.4% |
| 11 | 斷線<br>Broken line           | 顯示畫面中少直、橫線 拒收<br>There is a lack of vertical or horizontal lines in the view area.<br>Reject                                                                                                                                                                   | A | 電訊<br>Electronics | 主要<br>Major<br>AQL 0.4% |
| 12 | CROSS TALK                  | 顯示畫面時有局部之條紋或拖影<br>There are some stripes or shadow/smear showing in the view area.<br>拒收或與客端簽訂限度樣<br>Reject or inspect according to the golden sample                                                                                                          | A | 電訊<br>Electronics | 次要<br>Minor<br>AQL0.65% |
| 13 | I CON                       | 顯示畫面缺少部份顯示圖案 拒收<br>Lack of partial ICON in the view area.<br>Reject                                                                                                                                                                                            | A | 電訊<br>Electronics | 主要<br>Major<br>AQL 0.4% |

| 14                                       | 深淺不一<br>Color difference                          | 顯示畫面的對比，比其他顯示深或淺並依電氣規格(VOP)值判定<br>The color contrast of display is obviously lighter or darker than others and according to the VOP value in the electronics specification.<br>拒收或與客端簽訂限度樣<br>Reject or inspect according to the golden sample                                                                                                                                                                                                                                                                                                                                                   | A  | 電訊<br>Electronics | 次要<br>Minor<br>AQL0.65% |         |       |                  |                                          |                                                   |                  |                                 |       |              |   |                  |                         |
|------------------------------------------|---------------------------------------------------|--------------------------------------------------------------------------------------------------------------------------------------------------------------------------------------------------------------------------------------------------------------------------------------------------------------------------------------------------------------------------------------------------------------------------------------------------------------------------------------------------------------------------------------------------------------------------------------------------|----|-------------------|-------------------------|---------|-------|------------------|------------------------------------------|---------------------------------------------------|------------------|---------------------------------|-------|--------------|---|------------------|-------------------------|
| 15                                       | 畫面異常<br>Abnormal screen                           | 通電後畫面出現未定義之電訊不良現象 拒收<br>After connecting to the power, there is an undefined electronics appearance showing in the view area.<br>Reject                                                                                                                                                                                                                                                                                                                                                                                                                                                          | A  | 電訊<br>Electronics | 主要<br>Major<br>AQL 0.4% |         |       |                  |                                          |                                                   |                  |                                 |       |              |   |                  |                         |
| 16                                       | 背光色不均<br>Uneven color of backlight                | ※ 點亮後 LED 有明暗不均現象依其均勻度判定 拒收<br>After lighting LEDs have brightness and darkness uneven the determined according to its uniformity. Reject<br>※ 點亮後 LED 色澤不一致 拒收<br>LED color is inconsistent after lighting. Reject                                                                                                                                                                                                                                                                                                                                                                              | A  | 電訊<br>Electronics | 次要<br>Minor<br>AQL0.65% |         |       |                  |                                          |                                                   |                  |                                 |       |              |   |                  |                         |
| 17                                       | 亮度不足<br>Lack of brightness                        | 波長、色座標、輝度與圖面標示定義不符 拒收<br>Wave length, chromatic coordinates, brightness don't correspond to the definition of the drawing. Reject                                                                                                                                                                                                                                                                                                                                                                                                                                                                | A  | 電訊<br>Electronics | 主要<br>Major<br>AQL 0.4% |         |       |                  |                                          |                                                   |                  |                                 |       |              |   |                  |                         |
| 18                                       | 背光腳柱<br>Backlit foot post                         | 斷裂、長度不一 拒收<br>Fracture, different length<br>Reject                                                                                                                                                                                                                                                                                                                                                                                                                                                                                                                                               | -- | 外觀<br>Appearance  | 次要<br>Minor<br>AQL0.65% |         |       |                  |                                          |                                                   |                  |                                 |       |              |   |                  |                         |
| 19                                       | 破損<br>Damaged                                     | <p>Y：破損寬 X：破損長<br/>Y: Damaged width X: Damaged length</p>  <table border="1"> <thead> <tr> <th>Y</th> <th>X</th> <th>判定<br/>Determination</th> </tr> </thead> <tbody> <tr> <td>Y ≤ 1.0</td> <td>-- --</td> <td>允收<br/>Acceptance</td> </tr> <tr> <td>未進入可視區<br/>Did not enter the viewing area</td> <td>≤ 1/8 玻璃該邊長<br/>≤ 1/8 The side length of the glass</td> <td>允收<br/>Acceptance</td> </tr> <tr> <td>進入可視區<br/>Enter the viewing area</td> <td>-- --</td> <td>拒收<br/>Reject</td> </tr> </tbody> </table> | Y  | X                 | 判定<br>Determination     | Y ≤ 1.0 | -- -- | 允收<br>Acceptance | 未進入可視區<br>Did not enter the viewing area | ≤ 1/8 玻璃該邊長<br>≤ 1/8 The side length of the glass | 允收<br>Acceptance | 進入可視區<br>Enter the viewing area | -- -- | 拒收<br>Reject | B | 外觀<br>Appearance | 次要<br>Minor<br>AQL0.65% |
| Y                                        | X                                                 | 判定<br>Determination                                                                                                                                                                                                                                                                                                                                                                                                                                                                                                                                                                              |    |                   |                         |         |       |                  |                                          |                                                   |                  |                                 |       |              |   |                  |                         |
| Y ≤ 1.0                                  | -- --                                             | 允收<br>Acceptance                                                                                                                                                                                                                                                                                                                                                                                                                                                                                                                                                                                 |    |                   |                         |         |       |                  |                                          |                                                   |                  |                                 |       |              |   |                  |                         |
| 未進入可視區<br>Did not enter the viewing area | ≤ 1/8 玻璃該邊長<br>≤ 1/8 The side length of the glass | 允收<br>Acceptance                                                                                                                                                                                                                                                                                                                                                                                                                                                                                                                                                                                 |    |                   |                         |         |       |                  |                                          |                                                   |                  |                                 |       |              |   |                  |                         |
| 進入可視區<br>Enter the viewing area          | -- --                                             | 拒收<br>Reject                                                                                                                                                                                                                                                                                                                                                                                                                                                                                                                                                                                     |    |                   |                         |         |       |                  |                                          |                                                   |                  |                                 |       |              |   |                  |                         |

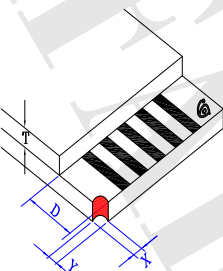

| 20                | 角崩<br>Corner<br>collapse                                   |                                                                                    | Y：破損寬 X：破損長<br>Y: Damaged width X: Damaged length <table border="1" data-bbox="566 537 1109 846"> <thead> <tr> <th>Y</th> <th>X</th> <th>判定<br/>Determination</th> </tr> </thead> <tbody> <tr> <td><math>\leq 1/3D</math></td> <td>-- --</td> <td>允收<br/>Acceptance</td> </tr> <tr> <td><math>1/3D &lt; Y \leq D</math></td> <td><math>\leq 1/8</math> 玻璃邊長<br/><math>\leq 1/8</math> The side length of the glass</td> <td>允收<br/>Acceptance</td> </tr> <tr> <td><math>&gt; D</math></td> <td>-- --</td> <td>拒收<br/>Reject</td> </tr> </tbody> </table> | Y   | X                                     | 判定<br>Determination     | $\leq 1/3D$ | -- -- | 允收<br>Acceptance | $1/3D < Y \leq D$ | $\leq 1/8$ 玻璃邊長<br>$\leq 1/8$ The side length of the glass | 允收<br>Acceptance | $> D$ | -- -- | 拒收<br>Reject | C | 外觀<br>Appearance | 次要<br>Minor<br>AQL0.65% |
|-------------------|------------------------------------------------------------|---------------------------------------------------------------------------------------------------------------------------------------------------------------------|----------------------------------------------------------------------------------------------------------------------------------------------------------------------------------------------------------------------------------------------------------------------------------------------------------------------------------------------------------------------------------------------------------------------------------------------------------------------------------------------------------------------------------------------------------|-----|---------------------------------------|-------------------------|-------------|-------|------------------|-------------------|------------------------------------------------------------|------------------|-------|-------|--------------|---|------------------|-------------------------|
| Y                 | X                                                          | 判定<br>Determination                                                                                                                                                 |                                                                                                                                                                                                                                                                                                                                                                                                                                                                                                                                                          |     |                                       |                         |             |       |                  |                   |                                                            |                  |       |       |              |   |                  |                         |
| $\leq 1/3D$       | -- --                                                      | 允收<br>Acceptance                                                                                                                                                    |                                                                                                                                                                                                                                                                                                                                                                                                                                                                                                                                                          |     |                                       |                         |             |       |                  |                   |                                                            |                  |       |       |              |   |                  |                         |
| $1/3D < Y \leq D$ | $\leq 1/8$ 玻璃邊長<br>$\leq 1/8$ The side length of the glass | 允收<br>Acceptance                                                                                                                                                    |                                                                                                                                                                                                                                                                                                                                                                                                                                                                                                                                                          |     |                                       |                         |             |       |                  |                   |                                                            |                  |       |       |              |   |                  |                         |
| $> D$             | -- --                                                      | 拒收<br>Reject                                                                                                                                                        |                                                                                                                                                                                                                                                                                                                                                                                                                                                                                                                                                          |     |                                       |                         |             |       |                  |                   |                                                            |                  |       |       |              |   |                  |                         |
| 21                | 尺寸量測<br>Size<br>Measurement                                | 未依圖面上標示 拒收<br>No correspond to the indication on the drawing.<br>Reject                                                                                             |                                                                                                                                                                                                                                                                                                                                                                                                                                                                                                                                                          | ALL | 外觀<br>Appearance                      | 主要<br>Major<br>AQL 0.4% |             |       |                  |                   |                                                            |                  |       |       |              |   |                  |                         |
| 22                | 其他<br>Other                                                | 如發現有上述未定義之不良則與客端簽訂限度樣<br>If there is another undefined defective situation. It will be listed as others. The inspection standard is according to the golden sample. |                                                                                                                                                                                                                                                                                                                                                                                                                                                                                                                                                          | ALL | 電訊<br>Electronics<br>外觀<br>Appearance | 次要<br>Minor<br>AQL0.65% |             |       |                  |                   |                                                            |                  |       |       |              |   |                  |                         |