

2441.75 MHz SMD SAW Filter

ABSTS5A2-45HM03BM

Request Samples



Check Inventory



1.1 x 0.9 x 0.5 mm
RoHS/RoHS II Compliant
MSL Level = 3

Features

- Usable Bandwidth of 83.5 MHz
- Compact Package Size
- Low Insertion Loss

Applications

- WiFi, ISM, Bluetooth Filter
- RF Front End for Wireless and Telecommunications Applications
- Mobile Applications

Electrical Specifications

Parameters		Specifications		
		Min	Typ	Max
Nominal Center Frequency (Fc) (MHz)			2441.75	
Insertion Loss (2400 ~ 2483.5 MHz) (dB)			2.2	2.6
Amplitude Ripple (2400 ~ 2483.5 MHz) (dB)			0.7	1.5
VSWR (2400 ~ 2483.5 MHz)			2.0	2.4
Temperature Coefficient (2400 ~ 2483.5 MHz) (ppm/°C)			-36	
Attenuation (dB)	0.1 – 960 MHz	30	35	
	1570 – 1990 MHz	32	35	
	2110 – 2170 MHz	40	45	
	2170 – 2300 MHz	30	35	
	2300 – 2320 MHz	25	33	
	2320 – 2345 MHz	18	25	
	2345 – 2365 MHz	10	15	
	2550 – 2800 MHz	15	20	
	2800 – 4000 MHz	30	33	
	4000 – 5000 MHz	30	33	
Terminating Source & Load Impedance (Ω)			50	
Maximum Input Power (dBm)			10	
DC Voltage (V)			3	

Mechanical Specifications

Parameters	Specifications
Filter Dimension	1.1 x 0.9 x 0.5 mm
Mounting Type	SMD Mount



5101 Hidden Creek Ln Spicewood TX 78669
Phone: 512-371-6159 | Fax: 512-351-8858
For terms and conditions of sales, please visit:
www.abracon.com

REVISED: 08-09-19

ABRACON IS
ISO9001-2015
CERTIFIED

2441.75 MHz SMD SAW Filter

ABSTS5A2-45HM03BM

Request Samples



Check Inventory



1.1 x 0.9 x 0.5 mm
RoHS/RoHS II Compliant
 MSL Level = 3

Environmental Specifications

Parameters	Specifications
Operating Temperature Range	-30°C ~ +85°C
Storage Temperature Range	-40°C ~ +105°C
RoHS/ RoHS II Compliant	Yes
MSL level	3
ESD Sensitive	Yes

Package Dimensions

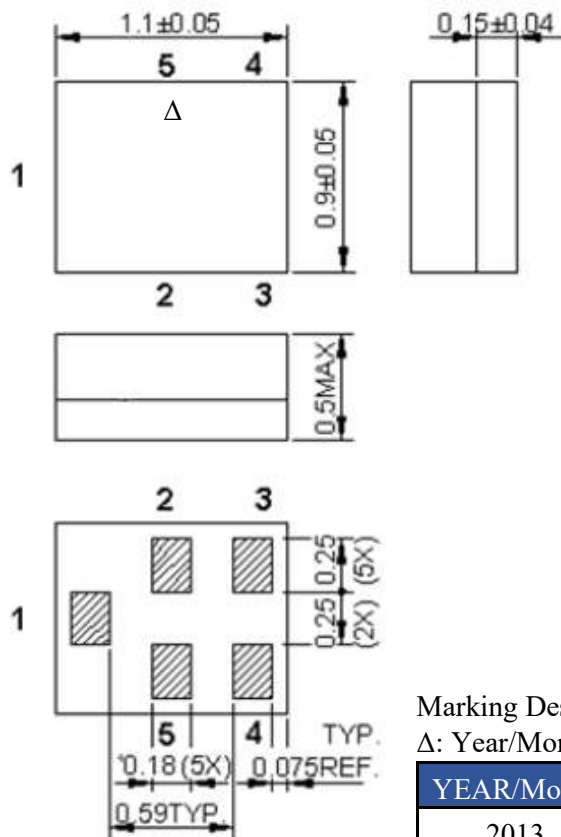

All tolerances are +/-0.05 mm unless otherwise specified
 Coplanarity: 0.1mm max
 1 to 5: Pin numbers
 Unit: mm

Pin No.	Symbol	Function
1	IN	Input
2	GND	Ground
3	GND	Ground
4	OUT	Output
5	GND	Ground

Marking Description:

Δ: Year/Month Code (Follow the table)

YEAR/Month	1	2	3	4	5	6	7	8	9	10	11	12
2013	A	B	C	D	E	F	G	H	J	K	L	M
2014	N	P	Q	R	S	T	U	V	W	X	Y	Z
2015	a	b	c	d	e	f	g	h	j	k	l	m
2016	n	p	q	r	s	t	u	v	w	x	y	z
2017	<u>A</u>	<u>B</u>	<u>C</u>	<u>D</u>	<u>E</u>	<u>F</u>	<u>G</u>	<u>H</u>	<u>J</u>	<u>K</u>	<u>L</u>	<u>M</u>
2018	<u>N</u>	<u>P</u>	<u>Q</u>	<u>R</u>	<u>S</u>	<u>T</u>	<u>U</u>	<u>V</u>	<u>W</u>	<u>X</u>	<u>Y</u>	<u>Z</u>
2019	<u>a</u>	<u>b</u>	<u>c</u>	<u>d</u>	<u>e</u>	<u>f</u>	<u>g</u>	<u>h</u>	<u>j</u>	<u>k</u>	<u>l</u>	<u>m</u>
2020	<u>n</u>	<u>p</u>	<u>q</u>	<u>r</u>	<u>s</u>	<u>t</u>	<u>u</u>	<u>v</u>	<u>w</u>	<u>x</u>	<u>y</u>	<u>z</u>

2441.75 MHz SMD SAW Filter

ABSTS5A2-45HM03BM

Request Samples



Check Inventory



1.1 x 0.9 x 0.5 mm
RoHS/RoHS II Compliant
MSL Level = 3

PCB Footprint

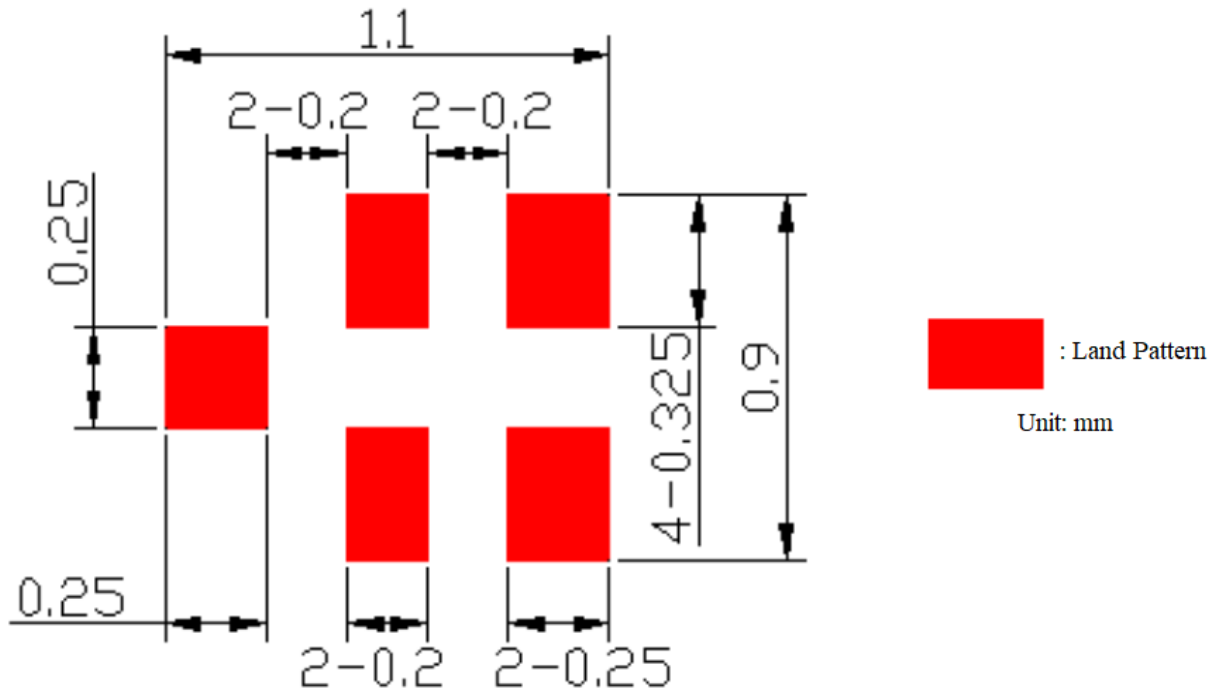

Measurement Circuit

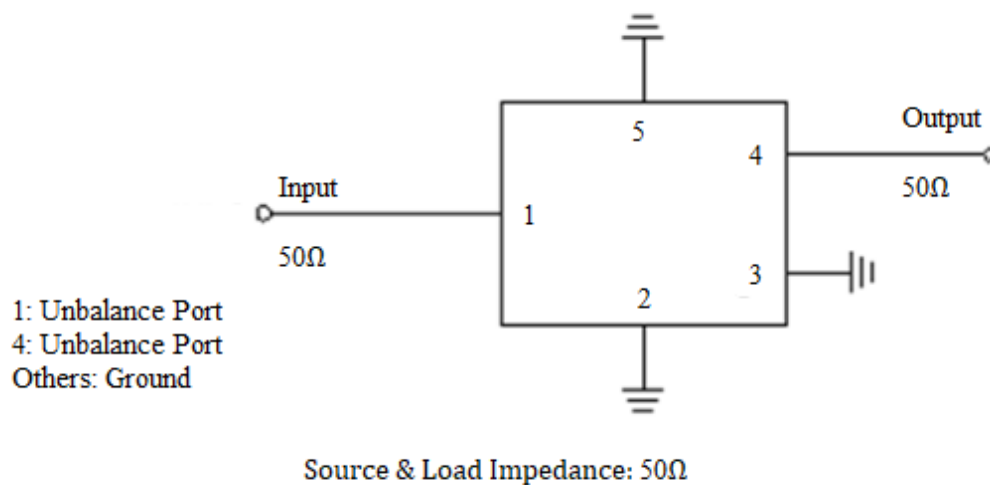

2441.75 MHz SMD SAW Filter

ABSTS5A2-45HM03BM

Request Samples



Check Inventory



1.1 x 0.9 x 0.5 mm
RoHS/RoHS II Compliant
MSL Level = 3

Transmission Characteristics

S21 (200 MHz Span)

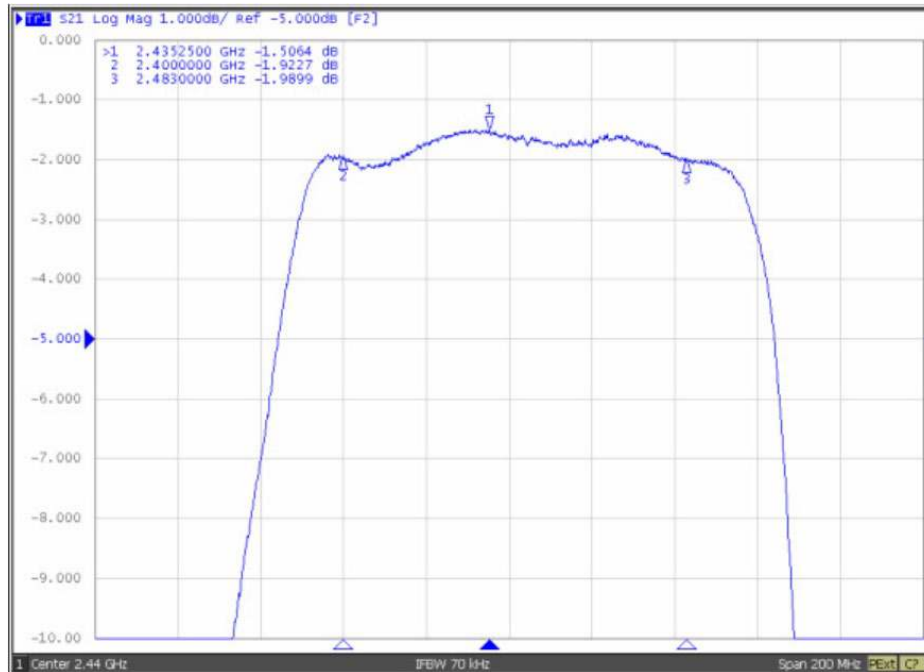

S21 (500 MHz Span)

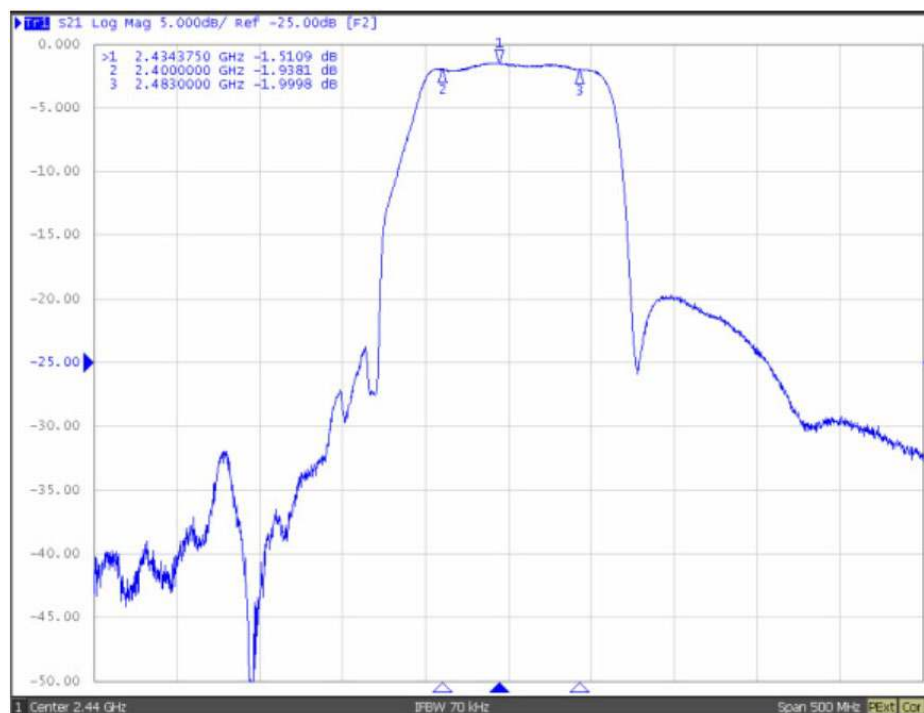

2441.75 MHz SMD SAW Filter

ABSTS5A2-45HM03BM

Request Samples



Check Inventory



1.1 x 0.9 x 0.5 mm
RoHS/RoHS II Compliant
MSL Level = 3

S21 (4.5 GHz Span)

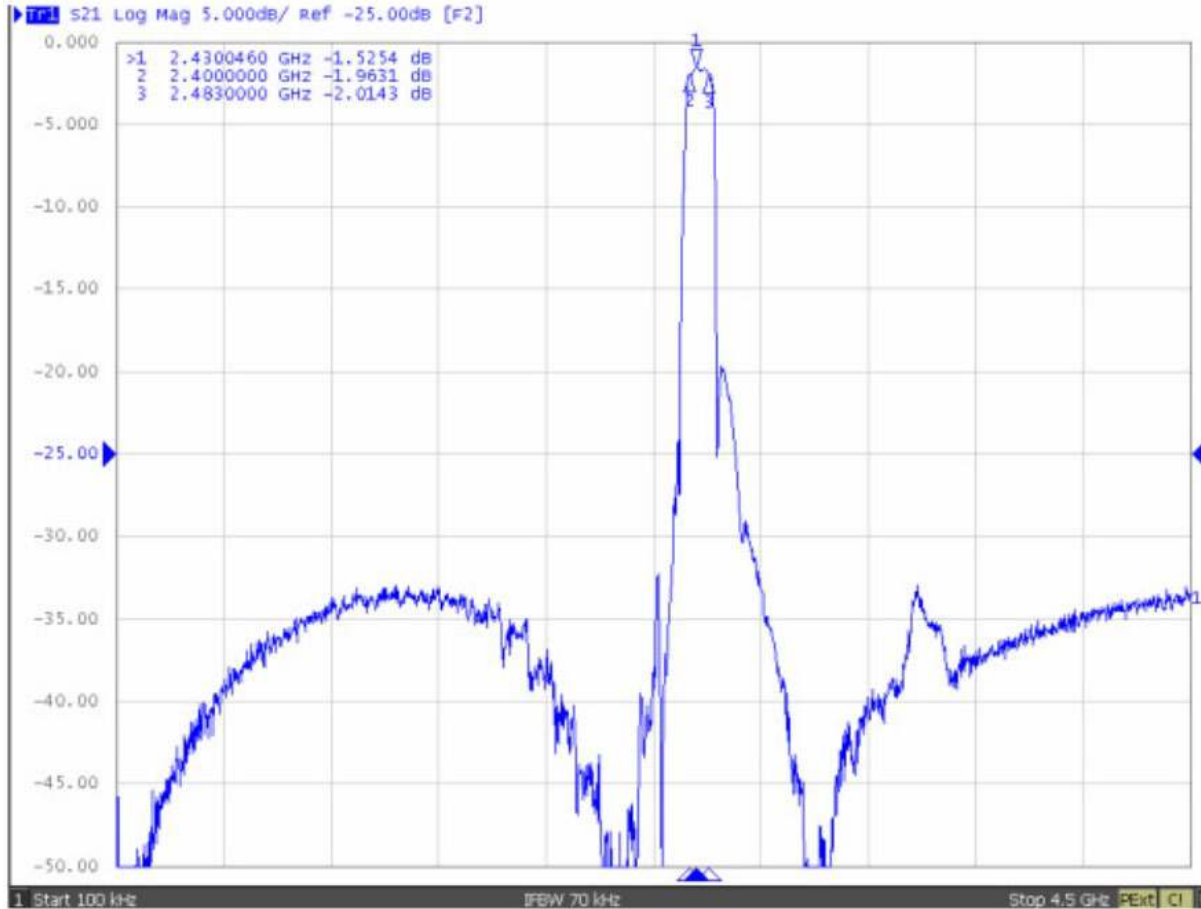

2441.75 MHz SMD SAW Filter

ABSTS5A2-45HM03BM

Request Samples



Check Inventory



1.1 x 0.9 x 0.5 mm
RoHS/RoHS II Compliant
MSL Level = 3

Smith Charts

S11 (Narrowband)

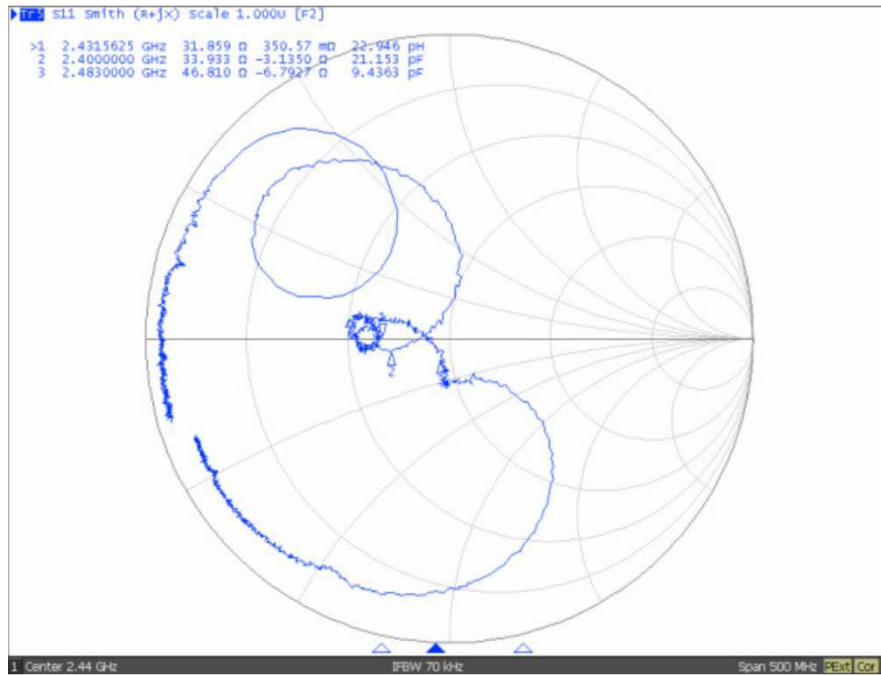

S22 (Narrowband)

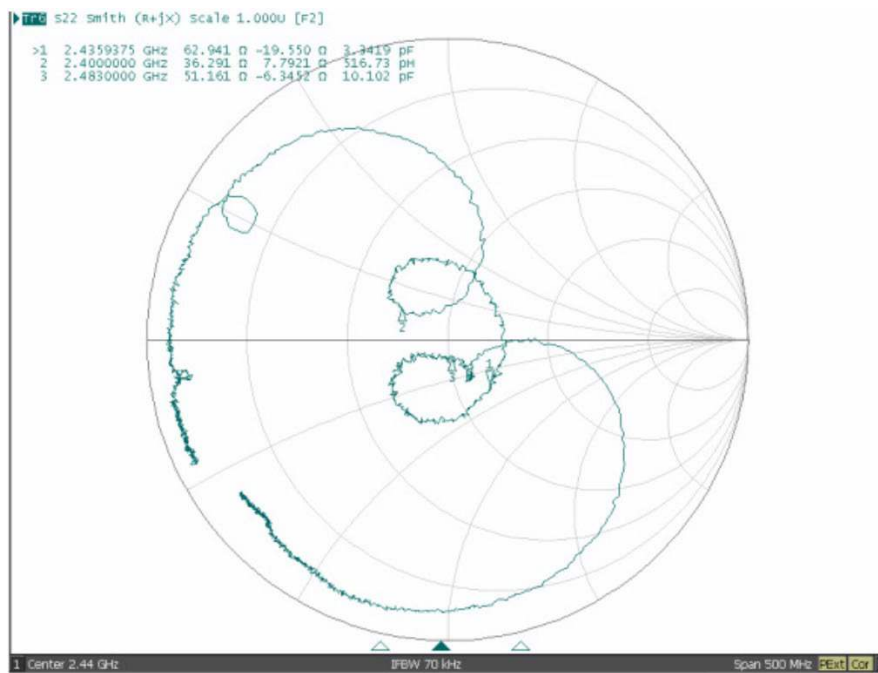

2441.75 MHz SMD SAW Filter

ABSTS5A2-45HM03BM

Request Samples



Check Inventory



1.1 x 0.9 x 0.5 mm
RoHS/RoHS II Compliant
MSL Level = 3

Recommended Reflow Profile

1. Preheating shall be fixed at 150°C~180°C for 60-90 seconds.
2. Ascending time to preheating temperature 150°C shall be 30 seconds minimum.
3. Heating shall be fixed at 220°C for 50~80 seconds and at 260°C+0/-5°C peak (20~40sec.)
4. Time :2 times

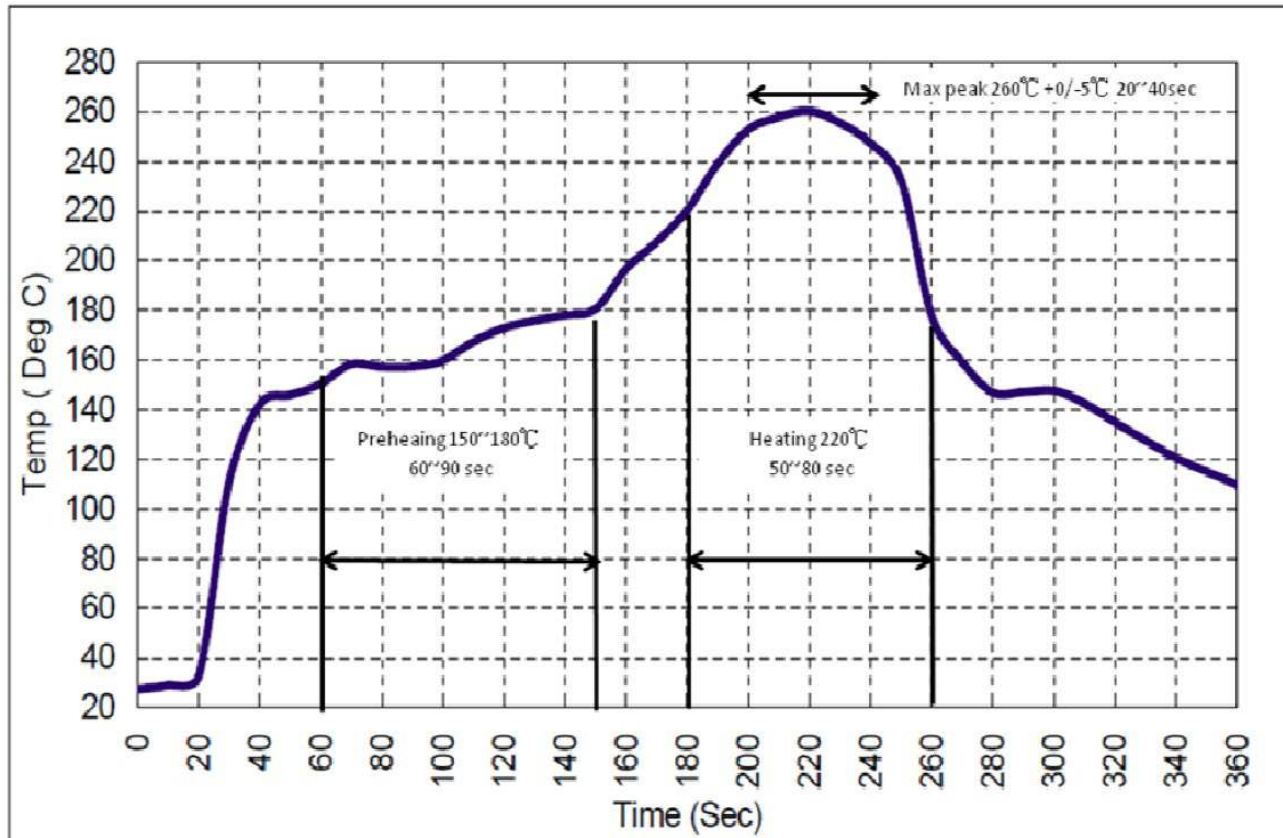

2441.75 MHz SMD SAW Filter

ABSTS5A2-45HM03BM

Request Samples



Check Inventory



1.1 x 0.9 x 0.5 mm
RoHS/RoHS II Compliant
MSL Level = 3

Packaging

Packaging Type: Reel and Tape
Pieces per Reel: 5k

Reel Dimension

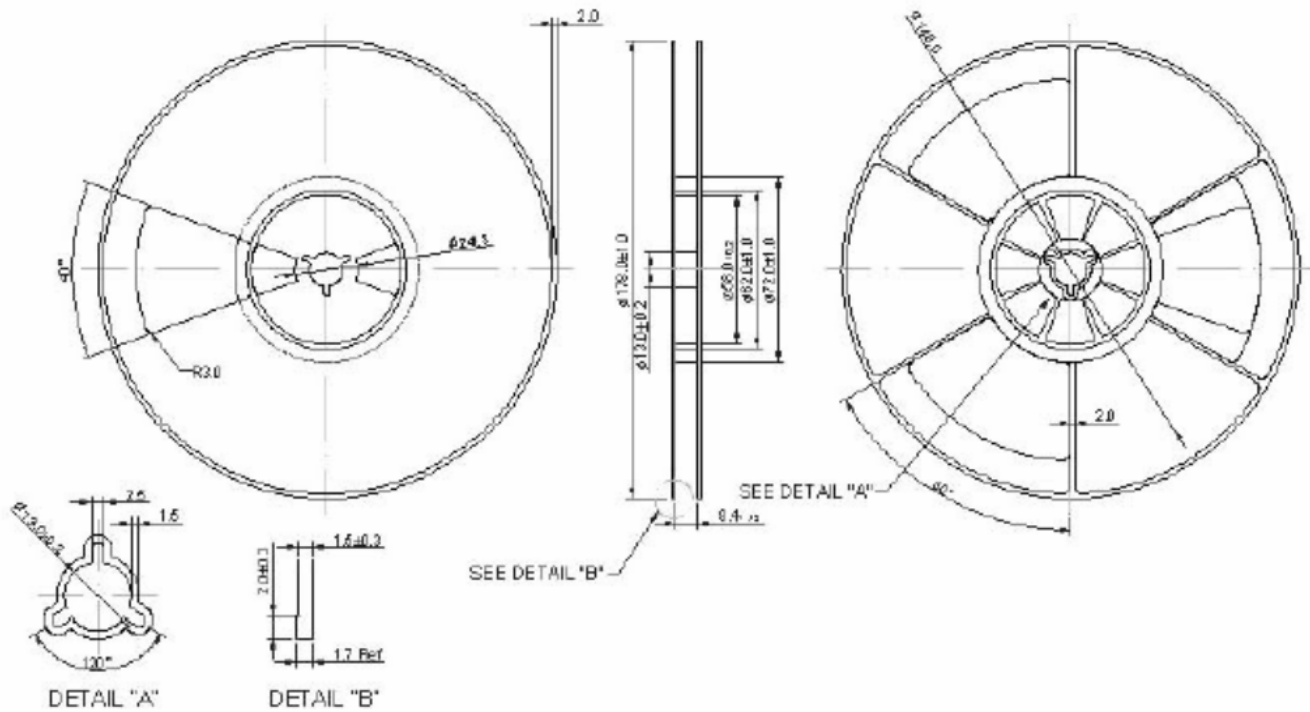

Unit: mm

2441.75 MHz SMD SAW Filter

ABSTS5A2-45HM03BM

Request Samples



Check Inventory



1.1 x 0.9 x 0.5 mm
RoHS/RoHS II Compliant
MSL Level = 3

Tape Dimension

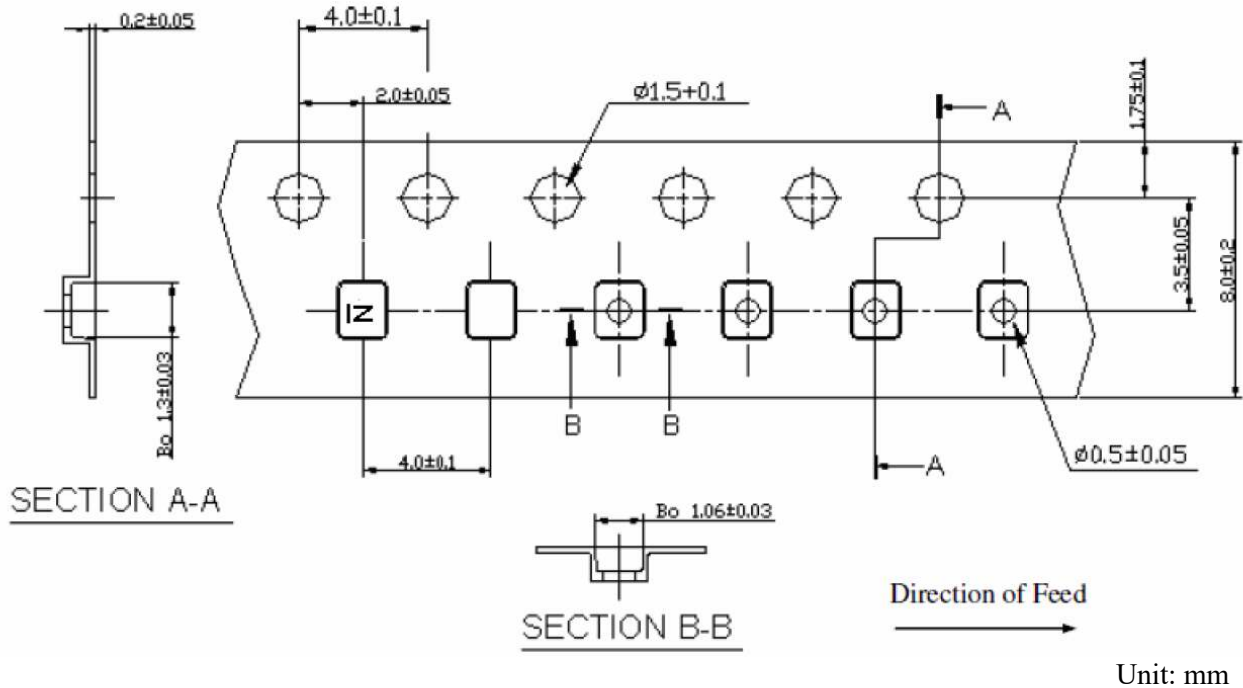

ATTENTION: Abracon LLC's products are COTS – Commercial-Off-The-Shelf products; suitable for Commercial, Industrial and, where designated, Automotive Applications. Abracon's products are not specifically designed for Military, Aviation, Aerospace, Life-dependent Medical applications or any application requiring high reliability where component failure could result in loss of life and/or property. For applications requiring high reliability and/or presenting an extreme operating environment, written consent and authorization from Abracon LLC is required. Please contact Abracon LLC for more information.



5101 Hidden Creek Ln Spicewood TX 78669
Phone: 512-371-6159 | Fax: 512-351-8858
For terms and conditions of sales, please visit:
www.abracon.com

REVISED: 08-09-19

ABRACON IS
ISO9001-2015
CERTIFIED