

REVISIONS				
P.	LTN	DESCRIPTION	DATE	APVD
P2		REVISED PER ECR-15-008260	03JUN2015	O.C D. Z

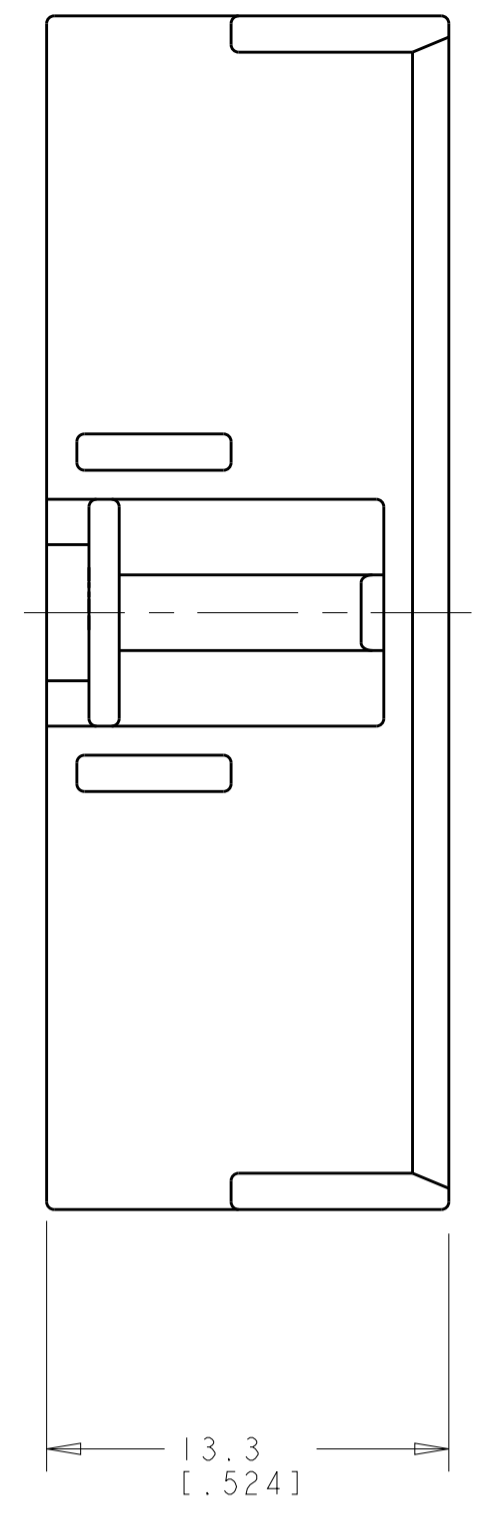

- △ MATERIAL : NYLON, UL94V-0, COLOR: NATURAL ;
- 2. APPLICABLE CONTACT P/N: 1123721-2 ;
- 3. MATING CONN. P/N: □ -1744037- □ ;
- △ P/N WITH TPA STRUCTURE ;

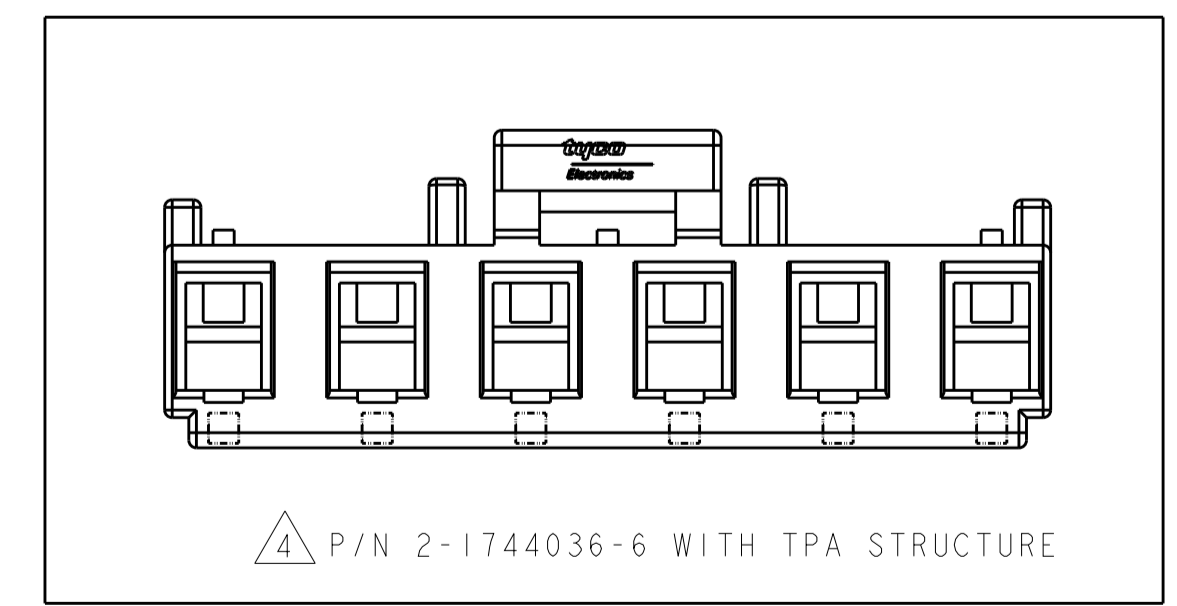
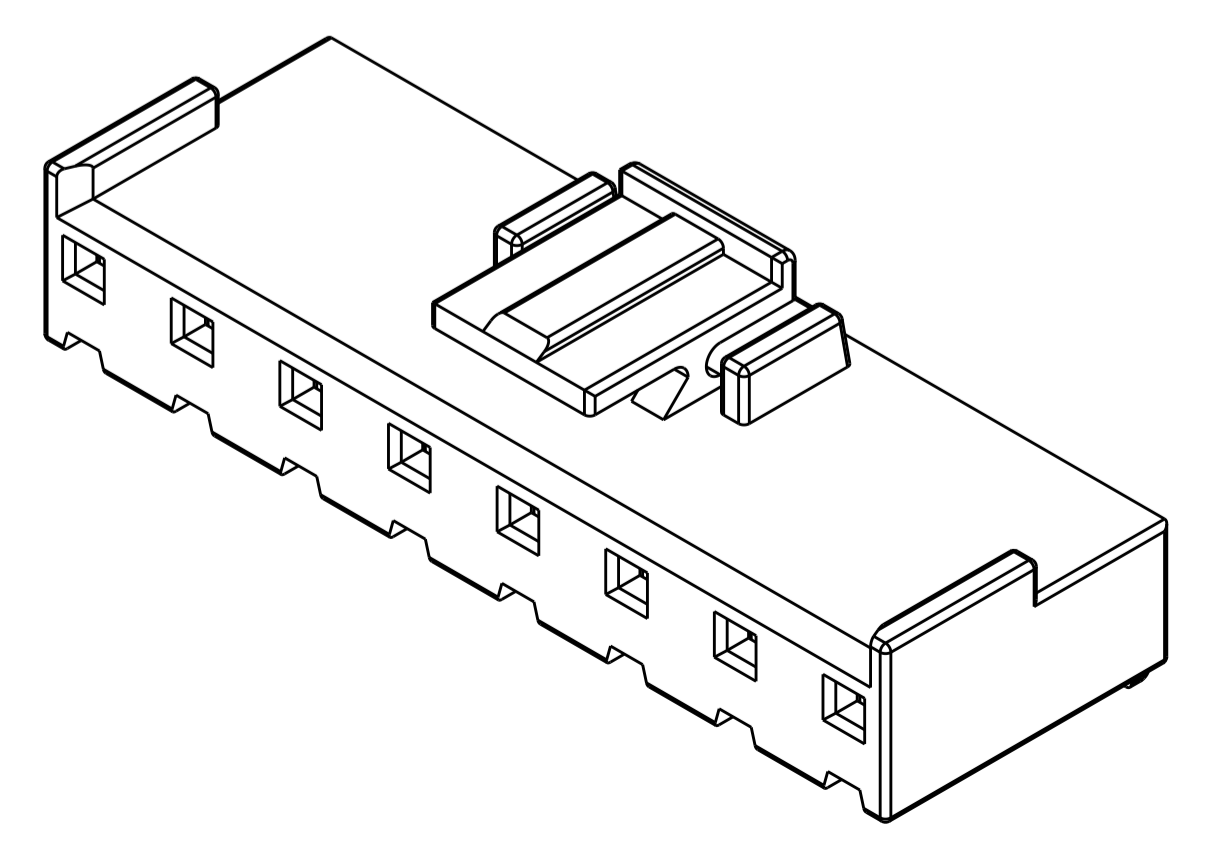
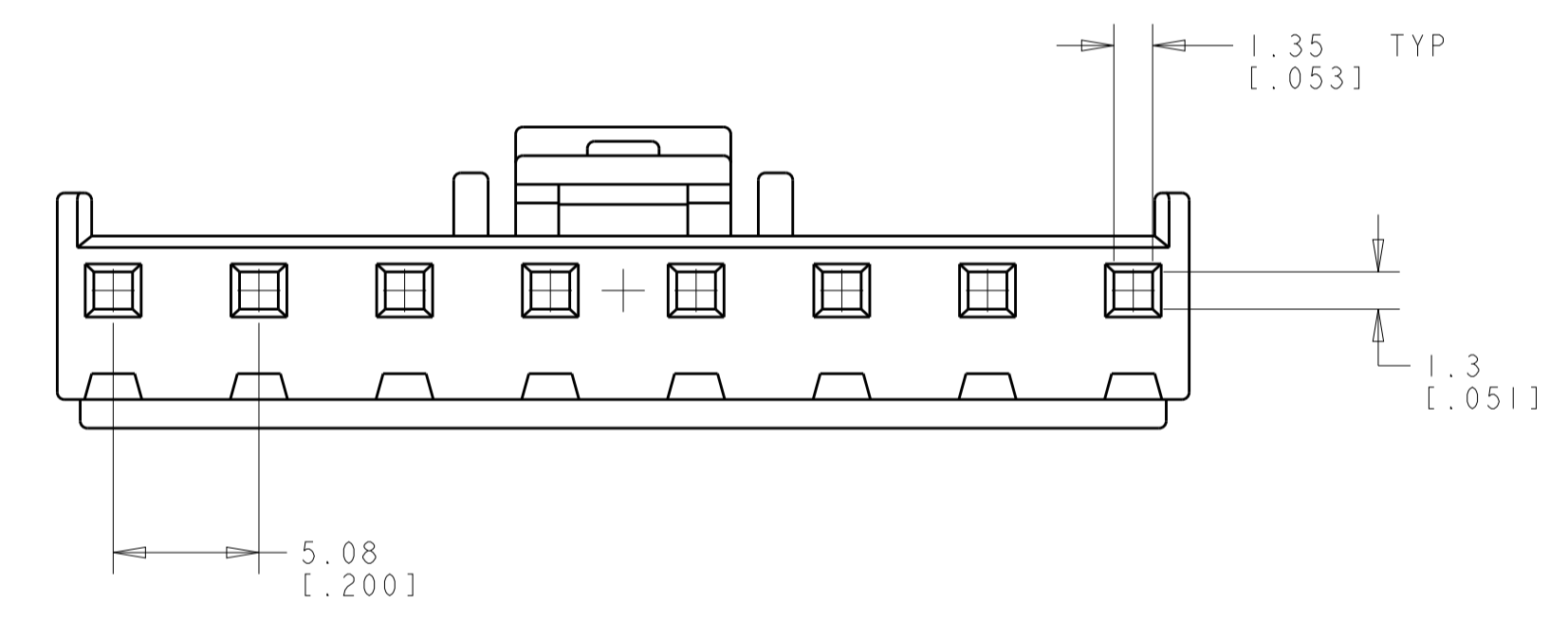
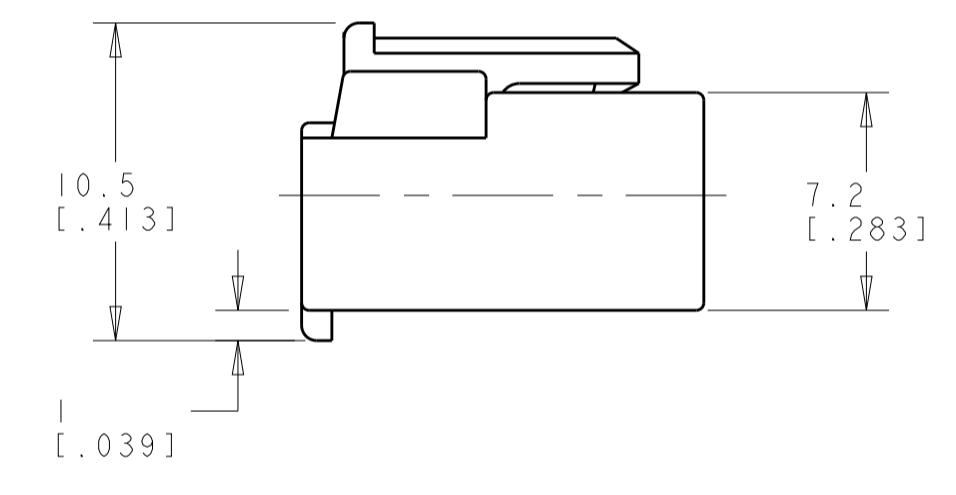
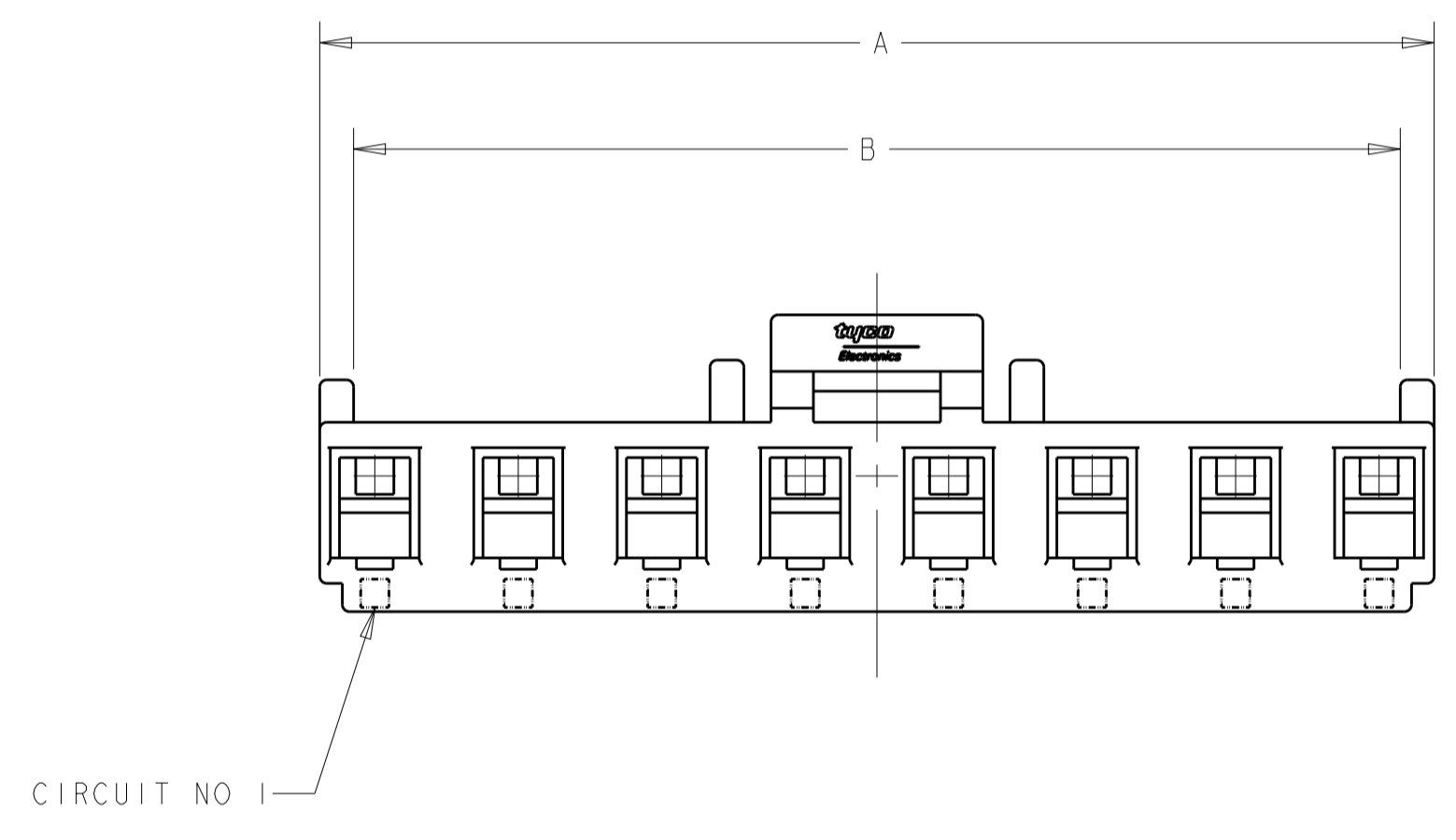

26.9 [1.059]	29.3 [1.154]	6	2-1744036-6
57.38 [2.259]	59.78 [2.354]	12	1-1744036-2
52.28 [2.058]	54.7 [2.154]	11	1-1744036-1
47.22 [1.859]	49.62 [1.954]	10	1-1744036-0
42.14 [1.659]	44.54 [1.754]	9	1744036-9
37.06 [1.459]	39.46 [1.554]	8	1744036-8
31.98 [1.259]	34.38 [1.354]	7	1744036-7
26.9 [1.059]	29.3 [1.154]	6	1744036-6
21.82 [0.859]	24.22 [0.954]	5	1744036-5
16.74 [0.659]	19.14 [0.754]	4	1744036-4
11.66 [0.459]	14.06 [0.554]	3	1744036-3
6.58 [0.259]	8.98 [0.354]	2	1744036-2
DIM B		DIM A	CKT PART NO.

THIS DRAWING IS A CONTROLLED DOCUMENT.		DWN R. WHITAKER 07OCT2004	TE Connectivity
DIMENSIONS: mm [inch]		CHK D. BOSSI 07OCT2004	
TOLERANCES UNLESS OTHERWISE SPECIFIED:		APVD D. BOSSI 07OCT2004	NAME RECEPTACLE, ECONOMY POWER, .200 CENTERLINE
0 PLC ±0.25 [0.01] 1 PLC ±0.25 [0.01] 2 PLC ±0.13 [0.005] 3 PLC ± 4 PLC ± ANGLES ± FINISH ±		PRODUCT SPEC 108-5609	RESTRICTED TO
MATERIAL		APPLICATION SPEC 114-13265	SIZE A100779
		WEIGHT	CAGE CODE DRAWING NO C=1744036
		CUSTOMER DRAWING	SCALE N/A SHEET 1 OF 1 REV P2