

MATERIAL NUMBER (STD.)	MATERIAL NUMBER (-50)	NO. OF CIRCUITS	A	B	C	D
386316602	386317202	2	43.4 (1.71)	11.13 (.438)	25.9 (1.02)	33.3 (1.31)
386316603	386317203	3	54.6 (2.15)	22.22 (.875)	37.1 (1.46)	44.5 (1.75)
386316604	386317204	4	65.7 (2.59)	33.35 (1.313)	48.3 (1.90)	55.6 (2.19)
386316605	386317205	5	76.7 (3.02)	44.45 (1.750)	59.2 (2.33)	66.5 (2.62)
386316606	386317206	6	87.9 (3.46)	55.57 (2.188)	70.4 (2.77)	77.7 (3.06)
386316607	386317207	7	99.1 (3.90)	66.67 (2.625)	81.5 (3.21)	88.9 (3.50)
386316608	386317208	8	110.2 (4.34)	77.80 (3.063)	92.7 (3.65)	100.0 (3.94)
386316609	386317209	9	121.2 (4.77)	88.90 (3.500)	103.6 (4.08)	111.0 (4.37)
386316610	386317210	10	132.3 (5.21)	100.03 (3.938)	114.8 (4.52)	122.2 (4.81)
386316611	386317211	11	143.5 (5.65)	111.13 (4.375)	125.9 (4.96)	133.4 (5.25)
386316612	386317212	12	154.7 (6.09)	122.25 (4.813)	137.2 (5.40)	144.5 (5.69)
386316613	386317213	13	165.6 (6.52)	133.35 (5.250)	148.1 (5.83)	155.4 (6.12)
386316614	386317214	14	176.8 (6.96)	144.45 (5.687)	159.3 (6.27)	166.6 (6.56)
386316615	386317215	15	188.0 (7.40)	155.58 (6.125)	170.4 (6.71)	177.8 (7.00)
386316616	386317216	16	199.1 (7.84)	166.70 (6.563)	181.6 (7.15)	189.0 (7.44)

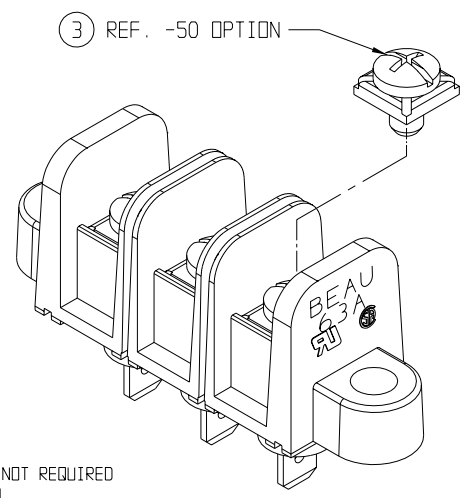
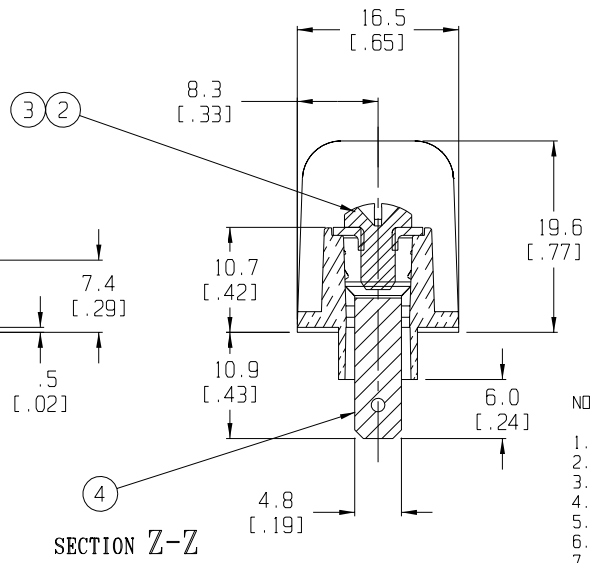
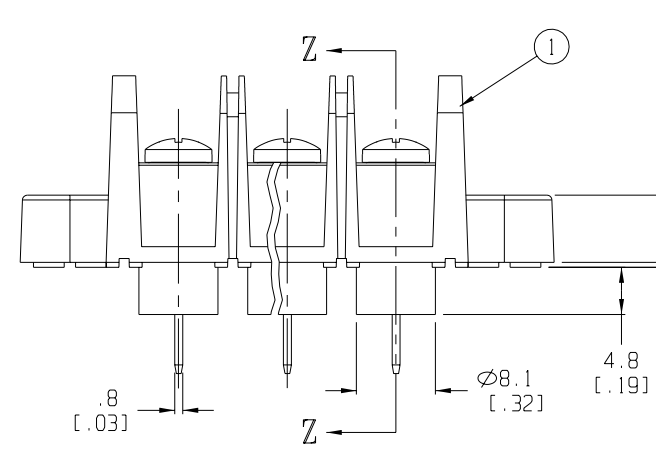

- NOTES:
1. MATERIAL: SEE TABLE
  2. FINISHES: SEE TABLE
  3. PRODUCT SPECIFICATION: NOT REQUIRED
  4. PACKAGING: NOT REQUIRED
  5. MATES WITH: NONE
  6. INCH DIMS ARE SHOWN IN PARENTHESIS (XXX)
  7. "XX" REFERS TO QTY. OF CIRCUITS

PROJECT NO. E-656	I	-
DIMENSIONS:	SHT	REV
<input checked="" type="checkbox"/> INCH	<input type="checkbox"/> INCH	<input type="checkbox"/> mm ONLY
<input type="checkbox"/> mm	<input type="checkbox"/> mm	<input type="checkbox"/> mm ONLY
	REVISE ON	CAD ONLY

ITEM	QTY.	DESCRIPTION	MATERIAL	FINISH
4	XX	TERMINAL, FAST-TAB	BRASS	TIN PLATE
3	XX	PAN HD. SCREW & WASHER, 6-32	BRASS	BRT. ZINC PLATE
2	XX	BINDING HD. SCREW, 6-32	STEEL	BRT. ZINC PLATE
1	1	BARRIER TERMINAL STRIP	PVC	BLACK

EC NO. ECO 11339	DESCRIPTION MAJOR
DRWN: R.STONE	CRITICAL
CHK: APPR:	SPC
REV A	S

GENERAL TOLERANCES: (UNLESS SPECIFIED)	SCALE 2:1	DESIGN UNITS <input type="checkbox"/> mm <input checked="" type="checkbox"/> INCH	THIRD ANGLE PROJECTION
4 PLACES ±.0015	DRAWN BY & DATE R.STONE 3-25-03	TITLE: 63A SERIES BTS, 600V, FAST-TAB SHORT STD. INSULATOR TURRET, MTG ENDS	MATERIAL NO. SEE CHART
3 PLACES ±.038 ±.005	CHECKED BY & DATE	MOLEX INCORPORATED	DRAWING NO. SD-38631-005
2 PLACES ±.13 ±.01	APPROVED BY & DATE	CAD FILENAME 63A9XX-001	SHEET NO. 1 OF 1
1 PLACE ±.3	ANGULAR: ±2°	THIS DRAWING CONTAINS INFORMATION THAT IS PROPRIETARY TO MOLEX INCORPORATED AND SHOULD NOT BE USED WITHOUT WRITTEN PERMISSION.	
DRAFT WHERE APPLICABLE MUST REMAIN WITHIN DIMENSIONS			SIZE B