

Model 405

Surface Mount Quartz Crystal



Part Dimensions:
5.0 × 3.2 × 0.85mm • 47mg

Features

- Hermetic Ceramic Surface Mount Package
- Fundamental Crystal Design
- Frequency Range 6.76438 – 54MHz
- Frequency Tolerance, ±30ppm Standard
- Frequency Stability, ±30ppm Standard
- Operating Temperature Range to -40°C to +105°C
- Tape and Reel Packaging, EIA-481

Standard Frequencies – see Page 5 for common frequencies.
* Check with factory for availability of frequencies not listed.

Applications

- IoT and IIoT Applications
- Wireless Communications
- FPGA/Microcontrollers
- USB Interfaces
- Computer Peripherals
- Portable Equipment
- Test and Measurement
- M2M Communications
- Broadband Access

Description

CTS Model 405 incorporates a high Q quartz resonator and is ideal for supporting a wide range of commercial and industrial applications.

Ordering Information

Model	Temperature Range	Tolerance @ +25°C	Temperature Stability	Load Capacitance	Frequency [MHz]
405	C	3	5	D	XXMXXXXX

Code	Temp. Range
C	-20°C to +70°C ¹
D	-30°C to +85°C ¹
I	-40°C to +85°C ²
G	-40°C to +105°C ³

Code	Stability
1	±10ppm
X	±15ppm
2	±20ppm
Y	±25ppm
3	±30ppm
5	±50ppm

Code	Tolerance	Code	Tolerance
1	±10ppm	Y	±25ppm
X	±15ppm	3	±30ppm
2	±20ppm		

Code	Capacitance	Code	Capacitance	Code	Capacitance
V	7pF	L	12pF	E	20pF
K	8pF	B	13pF	F	24pF
J	9pF	C	16pF	G	30pF
A	10pF	D	18pF	S	Series

Code	Frequency
	Frequency ⁴

Notes:

- 1] Available with all stability codes.
- 2] Available with stability codes X, 2, Y, 3 and 5.
- 3] Available with stability codes 3 and 5.
- 4] Frequency is recorded with 2 leading digits before the "M" and 5 significant digits after the "M" [including zeroes].
(Ex. XXMXXXXX [16M38400], XXMXXXXX [22M11840], XXMXXXXX [14M31818])

**Not all performance combinations and frequencies may be available.
Contact your local CTS Representative or CTS Customer Service for availability.**

This product is specified for use only in standard commercial applications. Supplier disclaims all express and implied warranties and liability in connection with any use of this product in any non-commercial applications or in any application that may expose the product to conditions that are outside of the tolerances provided in its specification.



Electrical Specifications

Operating Conditions

PARAMETER	SYMBOL	CONDITIONS	MIN	TYP	MAX	UNIT
Operating Temperature	T_A	-	-20		+70	
			-30	+25	+85	°C
			-40		+85	
			-40		+105	
Storage Temperature	T_{STG}	-	-55	-	+125	°C

Frequency Stability

PARAMETER	SYMBOL	CONDITIONS	MIN	TYP	MAX	UNIT
Frequency Range	f_o	Fundamental Mode		6.76438 - 54		MHz
Frequency Tolerance	$\Delta f/f_o$	@ +25°C		10, 15, 20, 25 or 30		±ppm
Frequency Stability	$\Delta f/f_{25}$	Referenced to +25°C reading		10, 15, 20, 25, 30 or 50		±ppm
Aging	$\Delta f/f_o$	Typical per year @ +25°C	-3	-	3	ppm

Crystal Parameters

PARAMETER	SYMBOL	CONDITIONS	MIN	TYP	MAX	UNIT
Operating Mode	-	-		Fundamental		-
Crystal Cut	-	-		AT-Cut Strip		-
Load Capacitance	C_L	-		See Ordering Information		pF
Shunt Capacitance	C_o	-	-	3.0	5.0	pF
Series Resistance						
Fundamental	R_1	6.76438MHz - <12MHz	-	-	100	
		12MHz - <14MHz	-	-	60	Ω
		14MHz - <20MHz	-	-	50	
		20MHz - 54MHz	-	-	40	
Drive Level	DL	-	-	10	300	μW
Insulation Resistance	R_i	+100Vdc ±15Vdc	500	-	-	MΩ

$\Delta f/f_o$ - Frequency deviation referenced to nominal frequency.

$\Delta f/f_{25}$ - Frequency deviation over operating temperature range, referenced to +25°C frequency.

Mechanical Specifications

Package Drawing

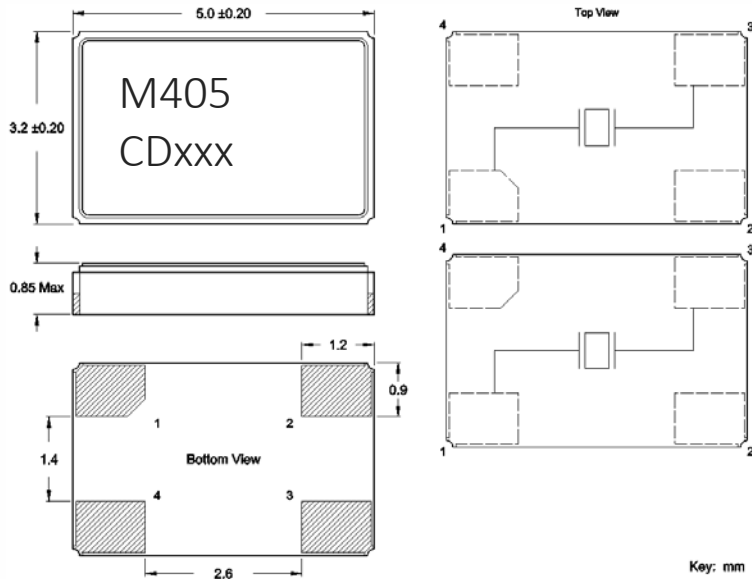

Marking Information

1. M405 – CTS model.
2. C – CTS.
2. D – Date Code. See Table I for codes.
3. xxx – Frequency Code.
3-digits, frequencies below 100MHz.
[See document 016-1454-0, Frequency Code Tables.]

Recommended Pad Layout

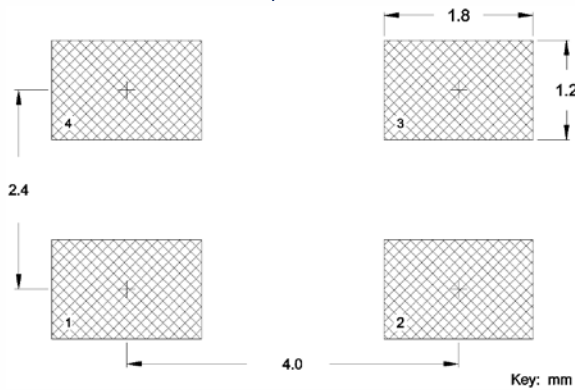

Notes

1. JEDEC termination code (e4). Barrier-plating is nickel [Ni] with gold [Au] flash plate.
2. Terminations #2, #4 and the metal lid are connected internally. End user may connect these pins to circuit ground for EMI suppression.
3. Due to package variability, the pad chamfer on the bottom could be located on Pin 1 or 4 in a given lot. Layout orientation should be based on the top view [marking side], as indicated in package drawing. The chamfer location does not affect the electrical performance of the device.
4. Reflow conditions per JEDEC J-STD-020; +260°C maximum, 20 seconds.
5. MSL = 1.

Table I – Date Code, Beginning year 2021

MONTH					JAN	FEB	MAR	APR	MAY	JUN	JUL	AUG	SEP	OCT	NOV	DEC
YEAR																
2021	2025	2029	2033	2037	A	B	C	D	E	F	G	H	J	K	L	M
2022	2026	2030	2034	2038	N	P	Q	R	S	T	U	V	W	X	Y	Z
2023	2027	2031	2035	2039	a	b	c	d	e	f	g	h	j	k	l	m
2024	2028	2032	2036	2040	n	p	q	r	s	t	u	v	w	x	y	z

Packaging – Tape and Reel

Tape Drawing

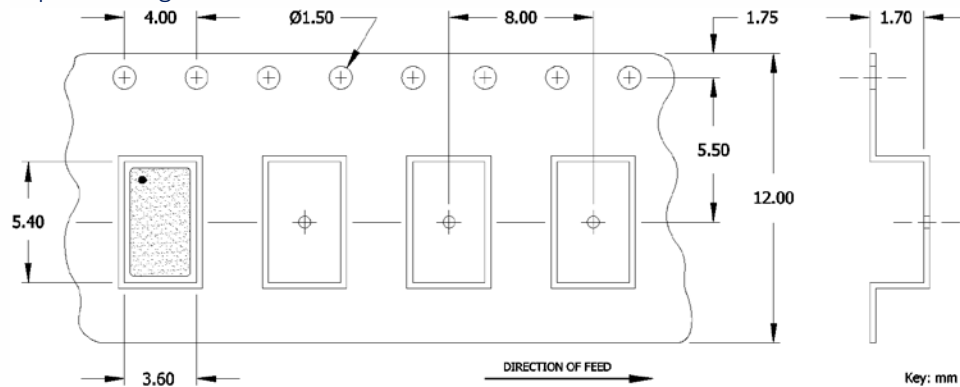

Reel Drawing

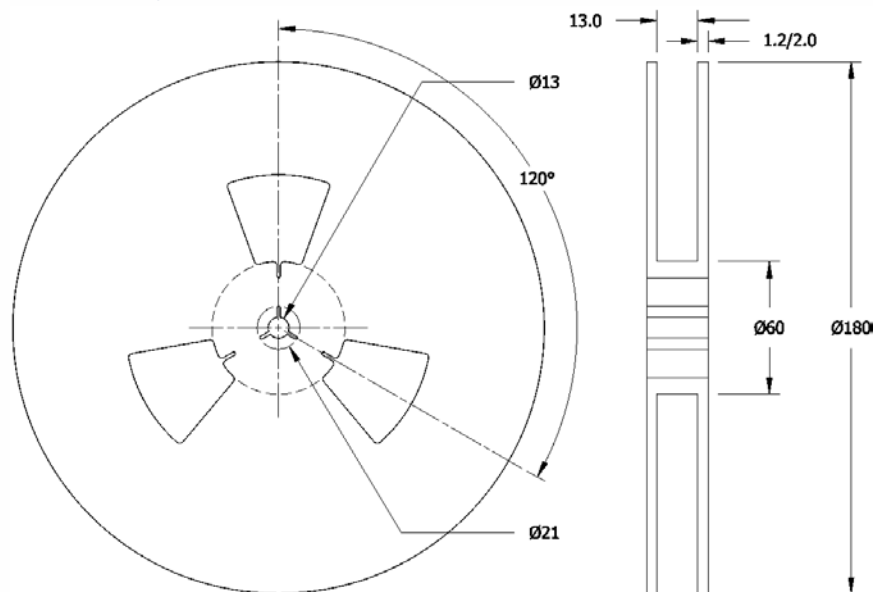

Notes

1. Device quantity is 1k pieces maximum per 180mm reel.
2. Complete CTS part number, frequency value, date code and manufacturing site code information must appear on reel and carton labels.



Addendum

Common Frequencies and Frequency Codes – MHz

Common Wireless Frequencies Additional Frequencies

FREQUENCY	FREQUENCY CODE	FREQUENCY	FREQUENCY CODE	FREQUENCY	FREQUENCY CODE	FREQUENCY	FREQUENCY CODE
12.000000	120	8.000000	080	18.000000	180	30.328000	303
13.560000	13C	8.192000	081	18.432000	184	30.400000	304
16.000000	160	10.000000	100	19.000000	190	30.720000	307
19.200000	192	11.059200	111	19.440000	194	31.250000	312
20.000000	200	12.288000	122	19.660800	19B	32.768000	327
24.000000	240	12.500000	125	19.680000	196	33.000000	330
25.000000	250	12.800000	128	19.800000	198	33.330000	333
26.000000	260	12.996000	12C	20.480000	204	33.333000	33E
27.120000	271	13.000000	130	20.736000	207	33.333300	33A
30.000000	300	13.500000	135	22.000000	220	33.868800	338
32.000000	320	13.553750	13B	22.118400	221	35.000000	350
37.400000	374	13.824000	138	22.579200	225	35.328000	353
38.400000	384	14.000000	140	24.305000	243	36.000000	360
40.000000	400	14.318180	143	24.545400	24F	38.000000	380
48.000000	480	14.400000	144	24.545454	24G	38.880000	388
52.000000	520	14.745600	147	24.553500	24B	39.062500	39A
		15.360000	153	24.576000	24C	41.600000	41C
		16.367600	16E	25.000625	25A	44.000000	440
		16.368000	16C	26.041660	26F	45.000000	450
		16.384000	163	27.000000	270	49.152000	491
		16.666000	166	28.224000	282	50.000000	500
		16.666700	16N	28.322000	28C	54.000000	540
		16.667000	16P	28.375000	283		
		16.800000	168	28.636360	286		
		16.934400	169	29.491200	29B		