

# Customer Information Sheet

DRAWING No.: S1751-XXR

IF IN DOUBT - ASK

©

NOT TO SCALE

THIRD ANGLE PROJECTION

ALL DIMENSIONS IN mm

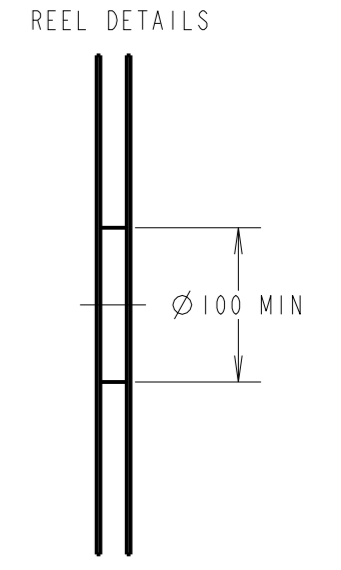
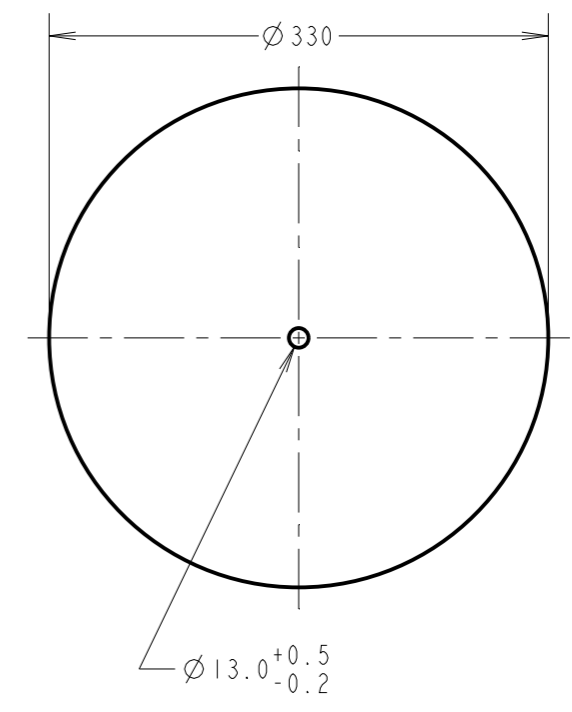
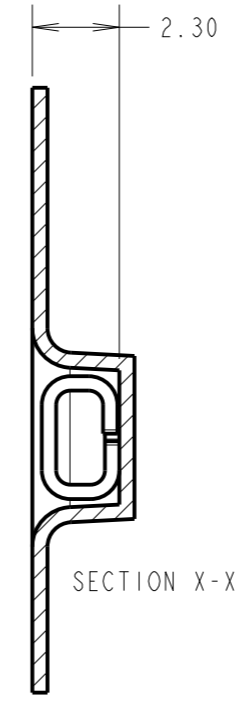
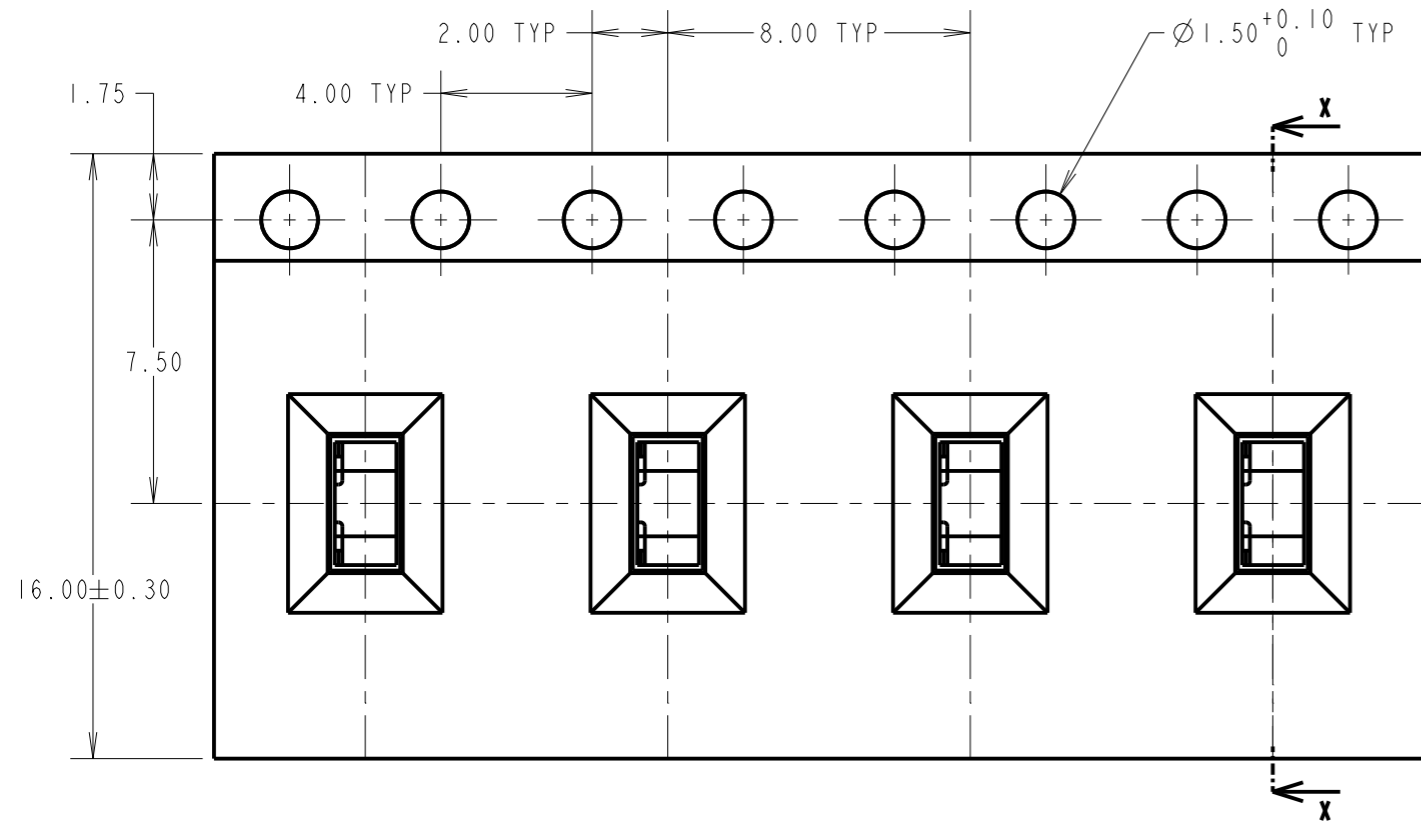

RECOMMENDED PAD LAYOUT  
TOLERANCE ±0.05mm

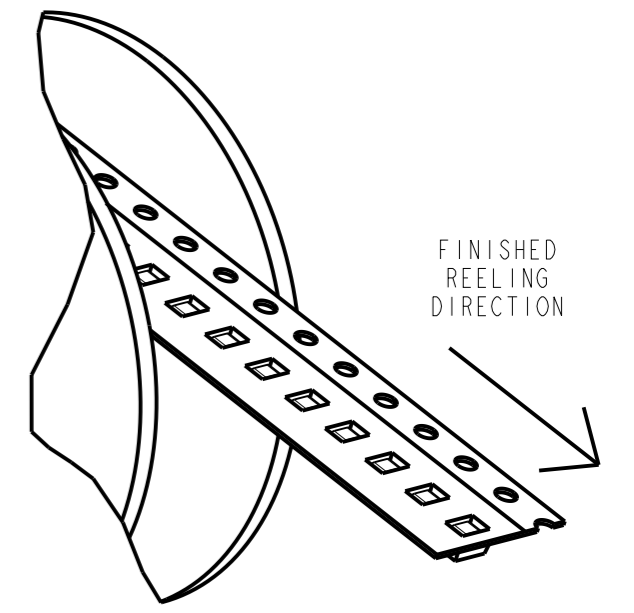
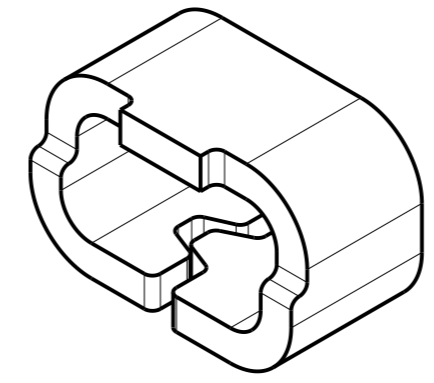
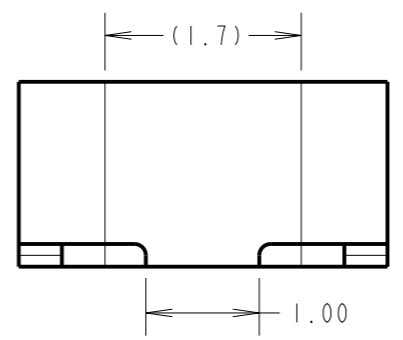
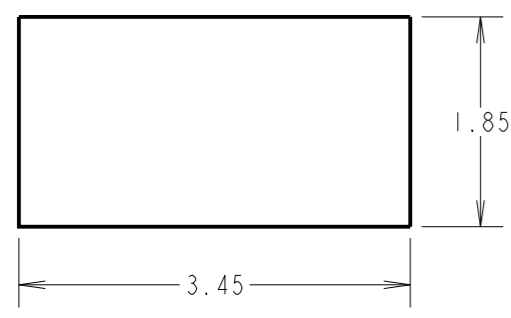

SPECIFICATIONS:  
 MATERIAL = BRASS  
 FINISH:  
 46 = 4µm 100% TIN  
 ELECTRICAL:  
 CURRENT RATING = 2A MAX  
 CONTACT RESISTANCE = 20mΩ MAX  
 ENVIRONMENTAL:  
 OPERATING TEMPERATURE = -55°C TO +125°C

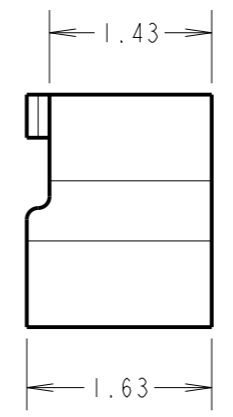
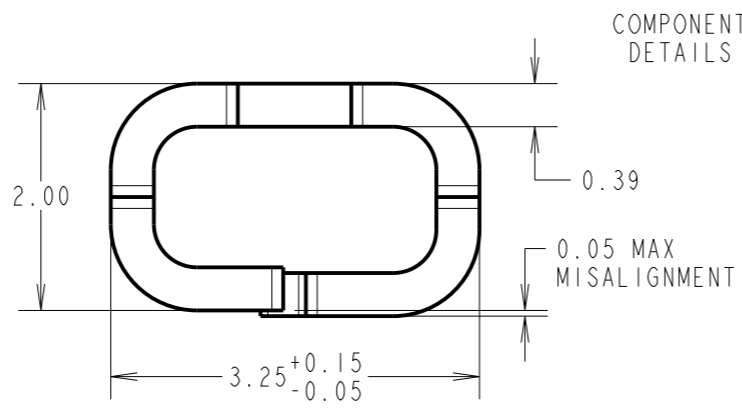

ORDER CODE	FINISH
S1751-46R	100% TIN

LW	10	15.02.23	32287
NAME	ISS.	DATE	CN/CO
APPROVED:		L. WALKER	
CHECKED:		A. BOXALL	
DRAWN:		W. J. BOURNE	
CUSTOMER REF.:			
ASSEMBLY DRG:			

- NOTES:
- QUANTITY PER REEL = 2,500.
  - THIS PRODUCT IS TAPED AND REELED IN ACCORDANCE WITH EIA-481-2-A (ELECTRONIC INDUSTRIES ASSOCIATION).
  - FOR LOOSE COMPONENTS, SEE S1751-XX.

**HARWIN**  
 www.harwin.com  
 technical@harwin.com

THIS DRAWING AND ANY INFORMATION OR DESCRIPTIVE MATTER SET OUT HEREON ARE CONFIDENTIAL AND COPYRIGHT PROPERTY OF THE HARWIN GROUP AND MUST NOT BE DISCLOSED, LOANED, COPIED OR USED FOR MANUFACTURING, TENDERING OR FOR ANY OTHER PURPOSE WITHOUT THEIR WRITTEN PERMISSION.

TOLERANCES  
 X. = ±1mm  
 X.X = ±0.50mm  
 X.XX = ±0.20mm  
 X.XXX = ±0.01mm  
 ANGLES = ±5°  
 UNLESS STATED

MATERIAL:  
 SEE ABOVE  
 FINISH: SEE ABOVE  
 S/AREA: mm<sup>2</sup>

TITLE:  
 SURFACE MOUNT TEST TERMINAL  
 (TAPE AND REELED)  
 DRAWING NUMBER:  
**S1751-XXR**  
 SHT 2 OF 2