

Long-Range AC/DC Photoelectric Sensor

E3K

Heavy-Duty Reflective Sensors Offer Long Sensing Distance

- Universal AC/DC supply voltage
- DPDT 10 A relay output standard
- Easy-to-wire terminal strip
- Plug-in replaceable outputs
- Light-ON/Dark-ON operation, switch selectable
- Mutual interference protection
- Timer modules available

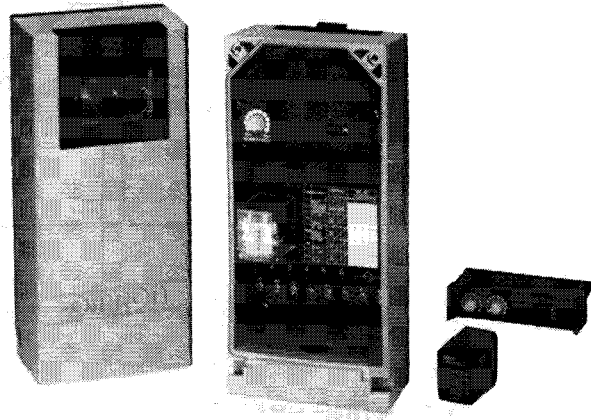

Ordering Information

■ SENSOR

Method of detection	Retroreflective	Diffuse reflective
Sensing distance	10 m (32.8 ft)	2 m (6.56 ft)
Part number	E3K-R10K4	E3K-D2K4

■ ACCESSORIES

Description	Part number	
Timer modules	Selectable ON-delay, OFF-delay or one-shot delay; 0.05 to 2 seconds or 0.5 to 20 seconds	E39-T1
	Dual ON- and OFF-delays; 0.05 to 2 seconds or 0.5 to 20 seconds	E39-T2
	Delayed one-shot; 0.05 to 2 seconds or 0.5 to 20 seconds	E39-T3
Reflector adapter for stud-mounting E39-R1 reflector	E39-L7	

■ REPLACEMENT PARTS

Description	Part number
Relay output module, DPDT, 10 A at 240 VAC max. load (supplied with each sensor)	LY2-DC12
Reflector (supplied with each sensor)	E39-R1
Mounting bracket (supplied with each sensor)	E39-L37

Specifications

Part number		E3K-R10K4	E3K-D2K4
Method of detection		Retroreflective	Diffuse reflective
Supply voltage		24 to 240 VAC, 50/60 Hz; 24 to 240 VDC	
Power consumption		10 VA max.	
Sensing distance		10 m (32.8 ft) with E39-R1 reflector included 12.2 m (40 ft) with 3 inch dia. reflector	2 m (6.56 ft) with 30 x 30 cm (11.8 x 11.8 in) 90% reflectance white mat paper
Light source		Pulse modulated infrared LED (950 nm)	
Detectable object type		Opaque materials	Opaque and translucent materials
Operation mode		Light-ON/Dark-ON, switch selectable	
Sensitivity		Adjustable potentiometer	
Mutual interference protection		Provided	
Control output	Relay	Type	DPDT
		Max. load	10 A, 240 VAC
		Min. load	1 mA, 5 VDC
Response time	On	Relay output	30 ms max.
	Off	Relay output	30 ms max.
Timing functions		See "Accessories" in Ordering Information	
Circuit protection	Output short-circuit	Not provided	
	DC power supply reverse polarity	Yes	
Indicators		Light Incident (red LED), Output Stability (green LED), Output Operation (yellow LED)	
Materials	Lens	Plastic	
	Case	Plastic	
Mounting		Bottom surface with three threaded metal inserts; Bracket (E39-L37) and hardware included	
Connections	Conduit	3/4-14 NPT	
	Wire	Plated steel screw terminals	
Weight		Without timer module: approx. 650 g (22.9 oz.) With timer module: approx. 690 g (24.3 oz.)	
Enclosure ratings	NEMA	1, 4, 4X, 12 and 13	
	IEC 144	IP67	
Approvals	UL	Listed, File number E41515	
	CSA	Certified, File Number LR 45951	
Ambient temperature	Operating	-25° to 55°C (-13° to 131°F)	
	Storage	-30° to 70°C (-22° to 158°F)	

■ TERMINAL ARRANGEMENT

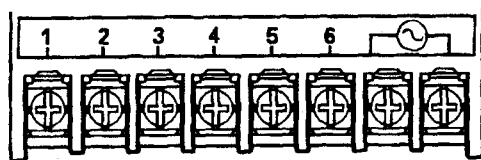

■ OUTPUT CIRCUIT DIAGRAMS

Relay output type

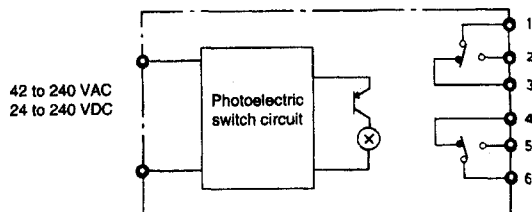

■ TIMING CHARTS

Each timer module is equipped with a NORMAL/REVERSE mode selector switch that provides greater flexibility in controlling the contact output state. In contrast to the Light-ON/Dark-ON mode selector switch that inverts the output state *before* the timing functions, the NORMAL/REVERSE mode selector switch

inverts the output state *after* the timing functions. In the NORMAL mode, the contact output state coincides directly with the set times on the timer module. In the REVERSE mode, the contact output state is the same as an inverted NORMAL mode output state.

E39-T1 ON-delay/OFF-delay/one-shot delay timer

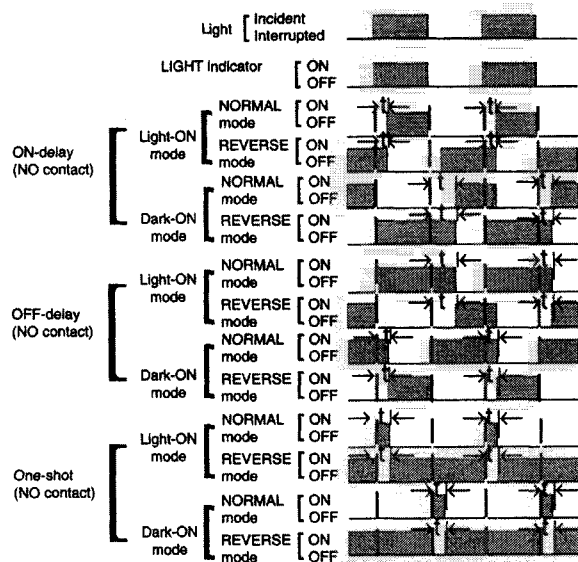

E39-T2 ON + OFF delay timer

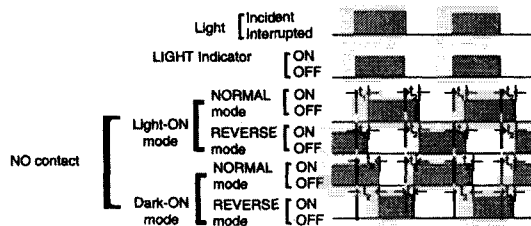

E39-T2 ON + OFF delay timer

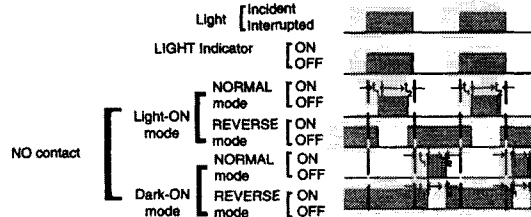

NOTE: $t = 0.05$ to 2 seconds or 0.5 to 20 seconds, switch selectable
 $t_d =$ Delay time: 0.05 to 2 seconds or 0.5 to 20 seconds, switch selectable
 $t_s =$ One-shot time: 0.05 to 2 seconds or 0.5 to 20 seconds, switch selectable

Engineering Data

■ EXCESS GAIN RATIO

E3K-R10K4

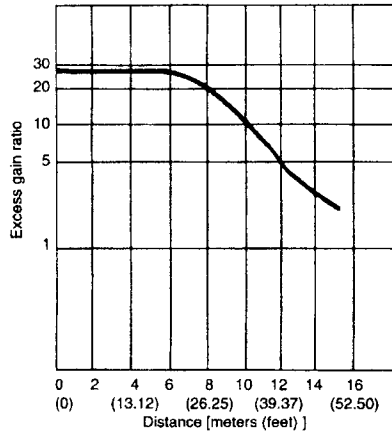

E3K-D2K4

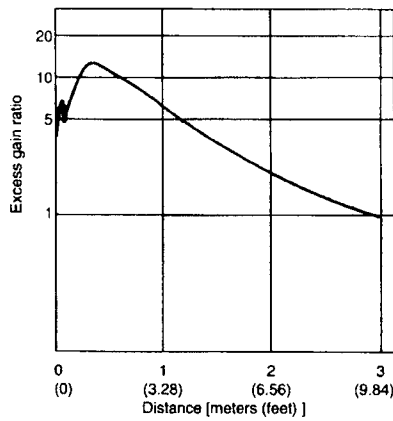

■ REFLECTOR SETTINGS RANGE

E3K-R10K4

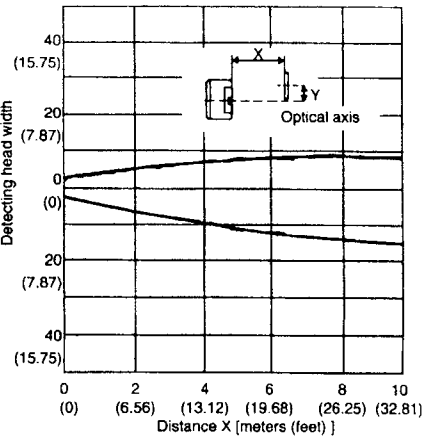

■ OPERATING RANGE

E3K-D2K4

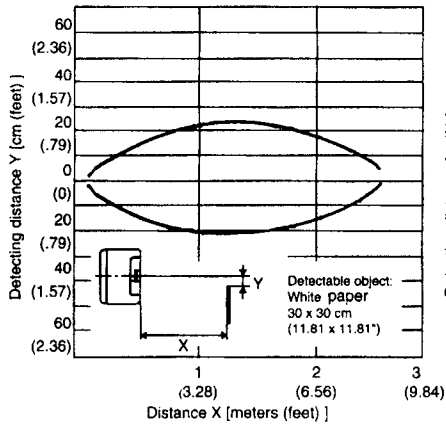

■ DETECTING DISTANCE VS. MINIMUM TARGET SIZE (AT MAXIMUM SENSITIVITY)

E3K-D2K4

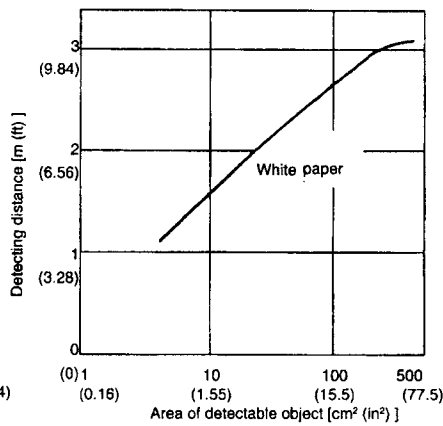

Dimensions

Unit: mm (inch)

SENSORS

E3K-□□□

Photoelectric Sensors

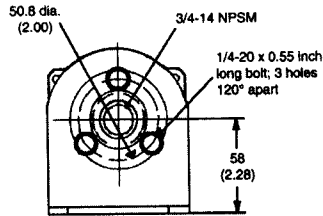
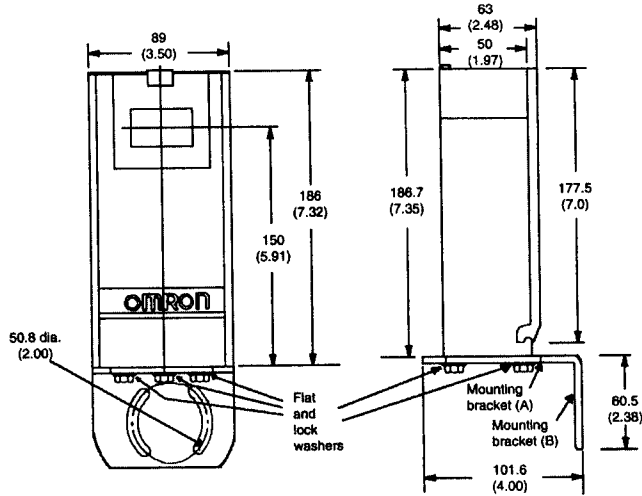
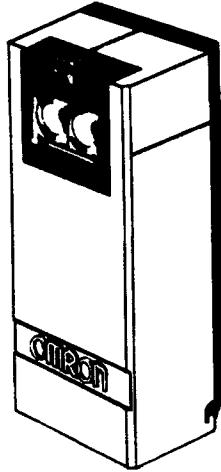

ACCESSORIES

E39-R1 Reflector

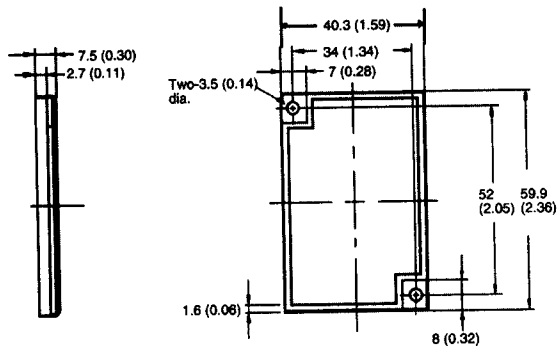

E39-L7 Reflector Adapter

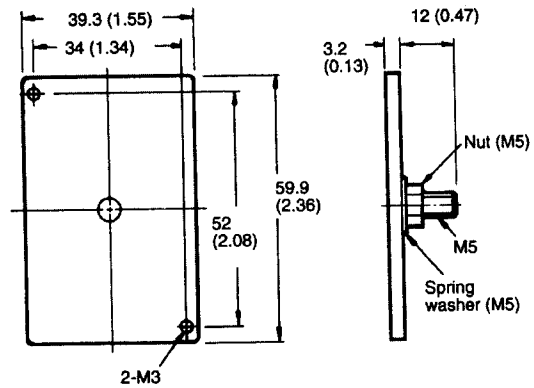

NOTE: DIMENSIONS SHOWN ARE IN MILLIMETERS. To convert millimeters to inches divide by 25.4.

OMRON AUTOMATION AND SAFETY • THE AMERICAS HEADQUARTERS • Hoffman Estates, IL USA • 847.843.7900 • 800.556.6766 • www.omron247.com

OMRON CANADA, INC. • HEAD OFFICE

Toronto, ON, Canada • 416.286.6465 • 866.986.6766 • www.omron247.com

OMRON ELECTRONICS DE MEXICO • HEAD OFFICE

México DF • 52.55.59.01.43.00 • 01-800-226-6766 • mela@omron.com

OMRON ELECTRONICS DE MEXICO • SALES OFFICE

Apodaca, N.L. • 52.81.11.56.99.20 • 01-800-226-6766 • mela@omron.com

OMRON ELETRÔNICA DO BRASIL LTDA • HEAD OFFICE

São Paulo, SP, Brasil • 55.11.2101.6300 • www.omron.com.br

OMRON ARGENTINA • SALES OFFICE

Cono Sur • 54.11.4783.5300

OMRON CHILE • SALES OFFICE

Santiago • 56.9.9917.3920

OTHER OMRON LATIN AMERICA SALES

54.11.4783.5300

OMRON EUROPE B.V. • Wegalaan 67-69, NL-2132 JD, Hoofddorp, The Netherlands. • +31 (0) 23 568 13 00 • www.industrial.omron.eu