

Product Specification**RoHS-6 Compliant
10 Gb/s 850nm XPAK Transponder****FTLX8551E3/ FTLX8551E3S/ FTLX8551F3****PRODUCT FEATURES**

- Hot pluggable XPAK MSA form factor
- Total power consumption: 2.2 W maximum
- RoHS-6 compliant (lead-free)
- Temperature range 0°C to 70°C
- Transmission distance of 300m
- Uncooled 850 nm VCSEL laser
- LC connector, multimode fiber
- Full duplex transmission mode
- Digital Optics Monitoring (DOM)
- Power supply: +5.0 V, +3.3 V, Adaptable Power Supply (APS: +1.2 V)
- XAUI electrical interface
 - 4 x 3.125 Gb/s Ethernet (FTLX8551E3/E3S)
 - 4 x 3.1875 Gb/s Fibre Channel (FTLX8551F3)
- Management and control via MDIO 2-wire bus
- Low profile version for front panel mounting
- 70-pin connector
- De-latch mechanism with low extraction force (FTLX8551x3 only)

**APPLICATIONS**

- 10GBASE-SR, 10G Ethernet (FTLX8551E3/E3S)
- 1200-Mx-SN-I Fibre Channel (FTLX8551F3)

PRODUCT SELECTION

Part Number	Application	De-Latch Mechanism
FTLX8551E3	Ethernet	Bail Release
FTLX8551E3S	Ethernet	Screw Mount
FTLX8551F3	Fibre Channel	Bail Release

I. Pin Descriptions

Signal Name	Level	I/O	Pin No.	Description
Management and Monitoring Ports				
MDIO	Open Drain	I/O	17	Management Data I/O. Requires external 10 - 22 k Ω pull-up to the APS on host.
MDC	1.2 V CMOS	I	18	Management Data Clock Input
PRTAD4	1.2 V CMOS	I	19	Port Address Input bit 4
PRTAD3	1.2 V CMOS	I	20	Port Address Input bit 3
PRTAD2	1.2 V CMOS	I	21	Port Address Input bit 2
PRTAD1	1.2 V CMOS	I	22	Port Address Input bit 1
PRTAD0	1.2 V CMOS	I	23	Port Address Input bit 0
LASI	Open Drain	O	9	Link Alarm Status Interrupt Output. Open Drain Compatible Output with 10 - 20 k Ω pull-up on host. Logic high = Normal Operation Logic low = Status Flag Triggered
RESET	Open Drain	I	10	Reset Input. Open Drain Compatible Input with 22 k Ω pull-up to APS internal to transponder. Logic high = Normal Operation Logic low = RESET
Vendor Specific			11,15,16,24	Vendor Specific Pins. Leave unconnected when not used.
TX ON/OFF	Open Drain	I	12	TX ON/OFF Input. Open Drain Compatible Input with 22 k Ω pull-up to APS internal to transponder. Logic high = Transmitter On Logic low = Transmitter Off
MOD DETECT		O	14	Pulled low inside transponder through a 1 k Ω resistor to Ground
Transmit Functions				
Reserved		I	68	Reserved For Future Use
Reserved		I	67	Reserved For Future Use
TX LANE 3–	AC-coupled, Internally biased differential XAUI	I	65	Module XAUI Input Lane 3–
TX LANE 3+		I	64	Module XAUI Input Lane 3+
TX LANE 2–		I	62	Module XAUI Input Lane 2–
TX LANE 2+		I	61	Module XAUI Input Lane 2+
TX LANE 1–		I	59	Module XAUI Input Lane 1–
TX LANE 1+		I	58	Module XAUI Input Lane 1+
TX LANE 0–		I	56	Module XAUI Input Lane 0–
TX LANE 0+	I	55	Module XAUI Input Lane 0+	

Pin Descriptions (continued)

Signal Name	Level	I/O	Pin No.	Description
Receive Functions				
Reserved		O	38	Reserved For Future Use
Reserved		O	39	Reserved For Future Use
RX LANE 0+	AC-coupled, Internally biased differential XAUI	O	41	Module XAUI Output Lane 0+
RX LANE 0–		O	42	Module XAUI Output Lane 0–
RX LANE 1+		O	44	Module XAUI Output Lane 1+
RX LANE 1–		O	45	Module XAUI Output Lane 1–
RX LANE 2+		O	47	Module XAUI Output Lane 2+
RX LANE 2–		O	48	Module XAUI Output Lane 2–
RX LANE 3+		O	50	Module XAUI Output Lane 3+
RX LANE 3–		O	51	Module XAUI Output Lane 3–
DC Power				
GND	0 V DC		1, 2, 3, 33, 34, 35, 36, 37, 40, 43, 46, 49, 52, 53, 54, 57, 60, 63, 66, 69, 70	Ground connection for signal ground on the module
APS	+1.2 V		7, 8, 28, 29	Input from Adaptive Power Supply
APS SENSE	+1.2 V		27	APS Sense Output. Connected to the APS input inside transponder.
APS SET			25	Feedback input from APS. Connected to GND through a 1180Ω resistor inside the transponder.
3.3 V	+3.3 V DC		5, 6, 30, 31	DC Power Input, +3.3 V DC, Nominal
5.0 V	+5.0 V DC		4, 32	DC Power Input, +5.0 V DC, Nominal
Reserved			26	Reserved for APD.
Reserved			13	Reserved.

Electrical Pad Layout

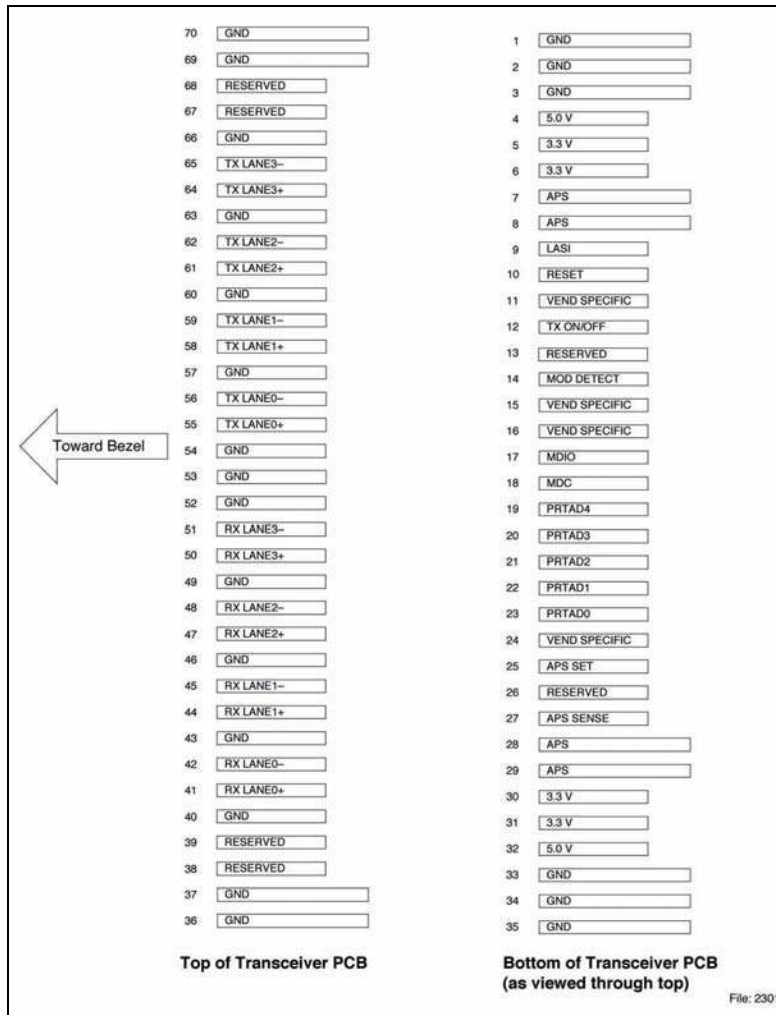

Figure 1 - XPAK Transponder Electrical Pad Layout

II. Absolute Maximum Ratings

Parameter	Symbol	Limit Values		Unit
		min.	max.	
Storage Ambient Temperature ¹⁾	T_S	-40	85	°C
Operating Case Temperature ¹⁾	T_C	0	70	°C
Supply Voltage +5.0 V	V_5	0	6	V
Supply Voltage +3.3 V	V_3	0	4	V
Supply Voltage APS	V_{aps}	0	1.5	V
Static Discharge Voltage, All Pins ²⁾	ST_d		500	V
Average Receive Optical Power	RX_P_{max}		0	dBm

Notes:

- 1) Non-condensing.
- 2) HBM

Exceeding any one of these values may permanently destroy the device.

III. Electrical Characteristics

Recommended Operating Conditions

Parameter	Symbol	Values			Unit
		min.	typ.	max.	
Operating Case Temperature ¹⁾	T_C	0		70	°C
Transponder Total Power Consumption	P			2.2	W
Supply Voltage +5.0 V	V_{CC5}	4.75	5.0	5.25	V
Supply Current +5.0 V	I_{CC5}		157	190	mA
Supply Voltage +3.3 V	V_{CC3}	3.14	3.3	3.47	V
Supply Current +3.3 V	I_{CC3}		55	72	mA
Supply Voltage APS	$V_{CC\text{aps}}$	1.152	1.2	1.248	V
Supply Current APS	$I_{CC\text{aps}}$		830	850	mA

¹⁾ Worst case thermal location, see also **Environmental Performance**.

Electrical DC Characteristics

($V_{CC5} = 4.75\text{ V to }5.25\text{ V}$, $V_{CC3} = 3.14\text{ V to }3.47\text{ V}$, $V_{CC\text{aps}} = 1.152\text{ V to }1.248\text{ V}$, $T_C = 0^\circ\text{C to }70^\circ\text{C}$)

Parameter	Symbol	Values			Unit
		min.	typ.	max.	
1.2 V CMOS I/O DC Characteristics (PRTAD; LASI; RESET; TX_ONOFF)					
External Pull-up Resistor for Open Drain	R_{pullup}	10		22	k Ω
Output High Voltage ²⁾	V_{oh}	1			V
Output Low Voltage ²⁾	V_{ol}			0.15	V
Input High Voltage	V_{ih}	0.84		1.5	V
Input Low Voltage	V_{il}			0.36	V
Input OFF Current ³⁾	I_{pd}	-1		1	μA
XAUI I/O DC Characteristics (TXLANE[0..3]; RXLANE[0..3])					
Differential Input Amplitude (pk-pk) ⁴⁾	$V_{\text{in_xaui}}$	160		2000	mV
Differential Output Amplitude (pk-pk) ⁴⁾	$V_{\text{out_xaui}}$	800		1600	mV
MDIO I/O DC Characteristics (MDIO; MDC)					
Output Low Voltage ⁵⁾	V_{OL}	-0.3		0.2	V
Output Low Current	I_{OL}			20	mA
Input High Voltage	V_{IH}	0.84		1.5	V
Input Low Voltage	V_{IL}	-0.3		0.36	V
Pull-up Supply Voltage	V_{PU}	0.84	1.2	1.5	V
Input Capacitance	C_{IN}			10	pF
Load Capacitance	C_{LOAD}			470	pF
External Pull-up Resistance	R_{LOAD}	200			Ω

²⁾ $R_{\text{pull-up}} = 10\text{ k}\Omega\text{ to }1.2\text{ V}$.

³⁾ $V_{\text{in}} = 1.2\text{ V}$.

⁴⁾ AC coupled.

⁵⁾ $I_{\text{OL}} = 100\ \mu\text{A}$.

Electrical AC Characteristics(V_{CC5} = 4.75 V to 5.25 V, V_{CC3} = 3.14 V to 3.47 V, V_{CCaps} = 1.152 V to 1.248 V, T_C = 0°C to 70°C)

Parameter	Symbol	Values			Unit
		min.	typ.	max.	
XAUI Input AC Characteristics (TXLANE[0..3])					
Baud Rate Fibre Channel Ethernet	R _{XAUIIN}		3.1875 3.125		Gbit/s
Baud Rate Tolerance	R _{TOLXAUI}	-100		100	Ppm
Differential Input Impedance	Z _{INXAUI}	80	100	120	Ω
Differential Return Loss ¹⁾	S ₁₁	10			dB
Jitter Amplitude Tolerance ³⁾	J _{XAUITOL}			0.65	UI _{p-p}
XAUI Output AC Characteristics (RXLANE[0..3])					
Baud Rate Fibre Channel Ethernet	R _{XAUIOUT}		3.1875 3.125		Gbit/s
Baud Rate Variation	R _{XAUIVAR}	-100		100	Ppm
XAUI Eye Mask (far-end)	According to IEEE and Fibre Channel				
Output Differential Impedance	Z _{OUTXAUI}	80	100	120	Ω
Differential Output Return Loss ¹⁾	S ₂₂	10			dB
Total Jitter ⁴⁾	TJ _{XAUI}			0.4	UI
Deterministic Jitter ⁴⁾	DJ _{XAUI}			0.17	UI
Power-On Reset AC Characteristics					
Power-On Reset and TX_ONOFF Characteristics	According to XENPAK MSA Issue 3.0 2002-9-18				
MDIO I/O AC Characteristics (MDIO; MDC)					
MDIO Data Hold Time	t _{HOLD}	10			Ns
MDIO Data Setup Time	t _{SU}	10			Ns
Delay from MDC Rising Edge to MDIO Data Change	t _{DELAY}			150	Ns
MDC Clock Rate	f _{MAX}			2.5	MHz

¹⁾ 100 MHz to 2.5 GHz.²⁾ At crossing point.³⁾ Per IEEE Std 802.3ae.⁴⁾ Far-end, measured values.

IV. Optical Characteristics

($V_{CC5} = 4.75 \text{ V to } 5.25 \text{ V}$, $V_{CC3} = 3.14 \text{ V to } 3.47 \text{ V}$, $V_{CCaps} = 1.152 \text{ V to } 1.248 \text{ V}$, $T_C = 0^\circ\text{C to } 70^\circ\text{C}$)

Parameter	Symbol	Values			Unit
		min.	typ.	max.	
Transmitter					
Launch Power in OMA ¹⁾	P_{O-OMA}	-2.8	-1.5		dBm
Average Launch Power ¹⁾	P_{O-Avg}	-5		-1	dBm
Center Wavelength Range ¹⁾	λ_{C-Tx}	840	850	860	Nm
RMS Spectral Width ¹⁾	σ_I		0.4	0.45	Nm
Extinction Ratio	ER	3	5.5		dB
Relative Intensity Noise ₁₂ OMA	RIN			-128	dB/Hz
Eye Mask Definition	According to IEEE and Fibre Channel				
Encircled Flux	EF	at $19 \mu\text{m} \geq 86\%$, at $4.5 \mu\text{m} \leq 30\%$			
Optical Return Loss Tolerance	ORL_T			12	dB
Average Launch Power of OFF Transmitter	P_{O-OFF}			-30	dBm
Receiver					
Stressed Receiver Sensitivity in OMA	P_{IN-S}			-7.5	dBm
Receiver Sensitivity in OMA ²⁾	P_{IN}			-11.1	dBm
Average Receive Power	P_{IN-max}			-1	dBm
Signal Detect Deassert Level	P_{SDL}			-14.5	dBm
Signal Detect Assert Level	P_{SD}	-18.0			dBm
Signal Detect Hysteresis	P_{SD}	0.5	1.5		dB
Receiver Reflectance	REF_{RX}			-12	dB
Center Wavelength Range	λ_{C-RX}	840		860	Nm

¹⁾ Conforms to IEEE triple trade-off between center wavelength, RMS spectral width and minimum OMA. Per IEEE 802.3ae, Average Launch Power is informative only.

²⁾ Receiver sensitivity, which is defined for an ideal input signal is informative only.

V. General Specifications

Optical Interface Standard Specifications

- IEEE Std 802.3ae-2002 clause 52, 10GBASE-SR
- Fibre Channel 10GFC Draft 4.0, 1200-M5-SN-I
- Fibre Channel 10GFC Draft 4.0, 1200-M5E-SN-I
- Fibre Channel 10GFC Draft 4.0, 1200-M6-SN-I
- XPAK MSA 2.3

Standard	Fiber Type	Minimum Modal Bandwidth at 850 nm (MHz*km)	Operating Range ¹⁾ (meters)
IEEE	62.5 μm MMF	160	2 to 26
	50 μm MMF	500	2 to 66
Fibre Channel	62.5 μm MMF	200	0.5 to 33
	50 μm MMF	500	0.5 to 82
	50 μm MMF	2000	0.5 to 300

¹⁾ Longer reaches possible depending upon link implementation.

Environmental Performance

Operating case temperature: 0°C to +70°C
Operating humidity: 0% -95% RH non-condensing

Fibers and Connectors

The transponder has LC receptacles for both Tx and Rx. The transponder is designed for multimode LC cables, 0° polished endface (PC).

70-pin Connector

The module interface connector is a 70-pin, printed circuit board edge connection with a 0.5 mm pitch. The appropriate mating connector for the customer PCB is a 70-pin SMT, dual row, right angled, edge connector, 0.5 mm pitch (Tyco Electronics part number 1367337-1, Molex part number 74441-0003 or equivalent).

Cage Requirement

The cage assembly required to mount the XPAK module is defined by the MSA. Finisar recommends the low profile design –For correct operation and implementation always follow the manufacturer’s datasheet.

A recommended XPAK rail assembly is Molex part number 74732-0220.

Aqueous Wash

Finisar XPAK transponders are neither solderable nor aqueous washable and are not intended for these processes.

VI. Regulatory Compliance

Feature	Standard	Comments
ESD: Electrostatic Discharge to the Electrical Pins (HBM)	EIA/JESD22-A114-B (MIL-STD 883D Method 3015.7)	Class 1a (> 500 V)
Immunity: Against Electrostatic Discharge (ESD) to the Module Receptacle	EN 61000-4-2 IEC 61000-4-2	Discharges ranging from ± 2 kV to ± 15 kV to the front end / faceplate / receptacle cause no damage to module (under recommended conditions).
Immunity: Against Radio Frequency Electromagnetic Field	EN 61000-4-3 IEC 61000-4-3	With a field strength of 10 V/m, noise frequency ranges from 10 MHz to 2 GHz. No effect on module performance between the specification limits.
Emission: Electromagnetic Interference (EMI)	FCC 47 CFR Part 15, Class B EN 55022 Class B CISPR 22	Noise frequency range: 30 MHz to 40 GHz Radiated emission does not exceed specified limits when measured with module inside a shielding enclosure with MSA conform cutout.
 <small>File: 1400</small>	Compliant with 89/336/EEC	EN 55022 EN 55024
FCC:		This device complies with part 15 of the FCC Class B Rules ¹⁾ . Operation is subject to the following two conditions: 1. This device may not cause harmful interference. 2. This device must accept any interference received, including interference that may cause undesired operation. 3. Must be used in a system housing.

Eye Safety

Finisar FTLX8551 transponders are Class 1 Laser Products. They are certified per the following standards:

Feature	Agency	Standard	Certificate Number
Laser Eye Safety	FDA/CDRH	CDRH 21 CFR 1040 and Laser Notice 50	9210176-77
Laser Eye Safety	TÜV	EN 60825-1: 1994+A11:1996+A2:2001 IEC 60825-1: 1993+A1:1997+A2:2001 IEC 60825-2: 2000, Edition 2	R 72052602
Electrical Safety	TÜV	EN 60950	R 72052602
Electrical Safety	UL/CSA	CLASS 3862.07 CLASS 3862.87	1439230

Copies of the referenced certificates will be available at Finisar Corporation upon request.

VII. DOM Parameters

Parameter	Values			Unit
	min.	typ.	max.	
Transponder Temperature Monitor Accuracy ¹⁾	-5		+5	°C
Laser Bias Current Monitor Accuracy ²⁾	-10		+10	%
Transmit Power Monitor Accuracy ³⁾	-3		+3	dB
Receive Power Monitor Accuracy	-3		+3	dB

¹⁾ 0 to 70°C case temperature.

²⁾ 0 to 12.5 mA.

³⁾ -1dBm to -3dBm.

VIII. Mechanical Specifications

Parameter	Symbol	Values			Unit
		min.	typ.	max.	
Module Retention Force (latch strength)	F _{RET}		200		N
Module Insertion Force	F _{IN}	1	40		N
Module Extraction Force (with kick-out)	F _{EXT-K}		16		N
Module Extraction Force (without kick-out)	F _{EXT}	0.84	25		N
0-80 UNF Screw Torque ¹⁾	T _{0-80 UNF}			10	cNm

1) Two 0-80 UNF screws are used to secure the XPAK module (no bail de-latch version FTLX8551E3S) in the cage. Each XPAK module is shipped with the screws, and assembly is required after the insertion of the module into the cage.

Package Outlines

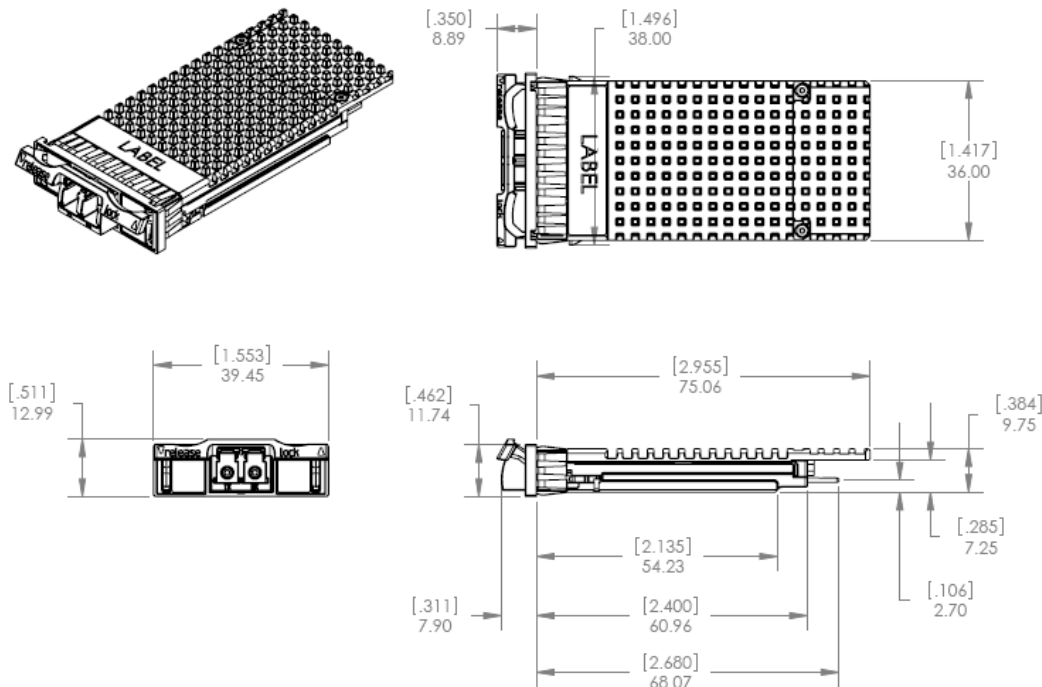

Figure 2 -XPAK with Bail De-Latch Mechanism

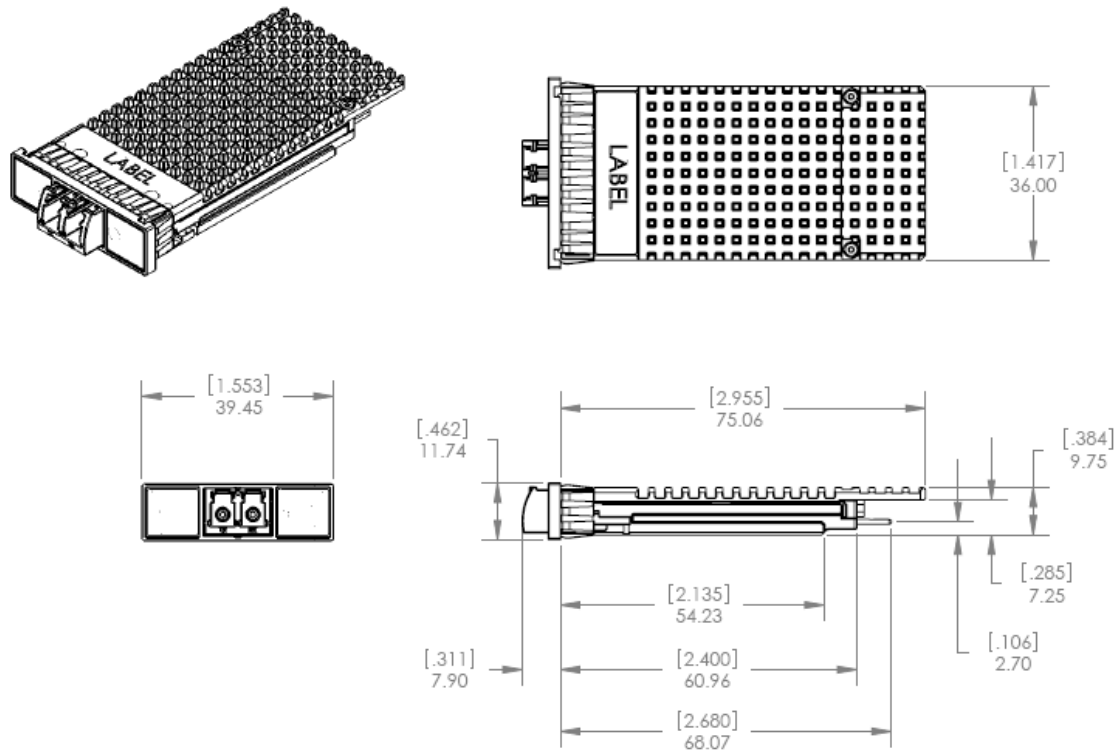

Figure 3 - XPAK with Screw Mount Assembly

IX. References

- IEEE Std 802.3æ™-2002 clause 45 & 47
- XPAK MSA 2.3

X. For More Information

Finisar Corporation
 1389 Moffett Park Drive
 Sunnyvale, CA 94089-1133
 Tel. 1-408-548-1000
 Fax 1-408-541-6138
sales@finisar.com
www.finisar.com