

HB LED driver with inhibit based on the ST1CC40 in an SO-8 BW package

Data brief



Description

The STEVAL-ILL046V2 evaluation board is based on the ST1CC40, which is an 850 kHz fixed switching frequency monolithic step-down DC-DC converter designed to operate as a precise constant current source with an adjustable current capability of up to 3 A DC.

In closed loop operation, the ST1CC40 feedback pin voltage is 100 mV, thus the sensing resistor calculation is expressed as $R_s = 100 \text{ mV}/I_{LED}$.

The STEVAL-ILL046V2 is provided with 660 mA by connecting a 150 mW sensing resistor to the feedback pin.

The overall application size is minimized, thanks to the high switching frequency and ceramic output capacitor compatibility.

The STEVAL-ILL046V2 evaluation board is fully protected against overheating, overcurrent and output short-circuit.

The inhibit mode minimizes the current consumption in standby (6 μA) to maximize battery life in portable devices.

Features

- 3 to 18 V operating input voltage range
- 850 kHz fixed switching frequency
- 100 mV (typ) current sense voltage drop
- 6 μA standby current in inhibit mode
- $\pm 7\%$ output current accuracy
- Synchronous rectification
- Embedded compensation network
- Internal current limiting
- Ceramic output capacitor compliant
- Thermal shutdown
- RoHS compliant

1 Schematic diagram

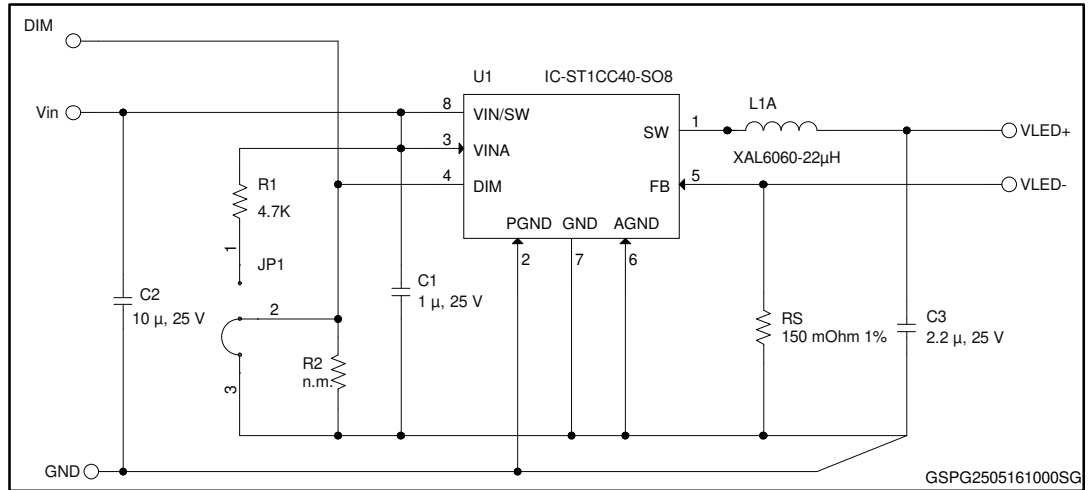
Figure 1: STEVAL-ILL046V2 circuit schematic

2 Revision history

Table 1: Document revision history

Date	Version	Changes
11-Feb-2013	1	Initial release.
25-May-2016	2	Updated: Figure 2 STEVAL-ILL046V2 circuit schematic.

IMPORTANT NOTICE – PLEASE READ CAREFULLY

STMicroelectronics NV and its subsidiaries ("ST") reserve the right to make changes, corrections, enhancements, modifications, and improvements to ST products and/or to this document at any time without notice. Purchasers should obtain the latest relevant information on ST products before placing orders. ST products are sold pursuant to ST's terms and conditions of sale in place at the time of order acknowledgement.

Purchasers are solely responsible for the choice, selection, and use of ST products and ST assumes no liability for application assistance or the design of Purchasers' products.

No license, express or implied, to any intellectual property right is granted by ST herein.

Resale of ST products with provisions different from the information set forth herein shall void any warranty granted by ST for such product.

ST and the ST logo are trademarks of ST. All other product or service names are the property of their respective owners.

Information in this document supersedes and replaces information previously supplied in any prior versions of this document.

© 2016 STMicroelectronics – All rights reserved