

Entube DE-HB

Specification Sheet for Verivolt Ultra-Compact, High-Bandwidth, Differential Voltage Sensor

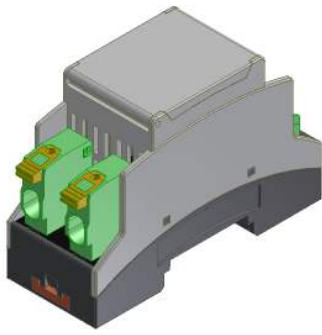

OVERVIEW

The Entube-DE-HB series was designed to enable measurement of fast high voltage signals in industrial and research environments. The output of the Entube-DE-HB is a linearly scaled down version of the voltage difference between its two input terminals. This output can then be processed by a computer based measurement system. The Entube-DE-HB series covers multiple input dynamic ranges ($\pm 100V$, $\pm 200V$, $\pm 300V$, $\pm 400V$, $\pm 500V$, $\pm 750V$, $\pm 1000V$ and $\pm 1500V$) with a 20MHz bandwidth, and 0.2% accuracy.

In addition to multiple dynamic ranges, the Entube-DE-HB can be ordered to have a single-ended or a differential-pair output. The single-ended version has a BNC connector at the output, and can be ordered as $\pm 10V$, $\pm 5V$ or $\pm 1V$.

SPECIFICATIONS

Entube DE-HB	100V	200V	300V	400V	500V	750V	1000V	1500V
Bandwidth (-3dB point)	20MHz							
Integrated sensor noise (Referenced to output)	< 380 μV	< 290 μV	< 350 μV	< 350 μV	< 350 μV	< 370 μV	< 650 μV	< 700 μV
Gain (Using 10V standard output voltage)	10	20	30	40	50	75	100	150
Input Impedance	2 M Ω 1pF		5M 1pF			10M Ω 1pF	20M Ω 1pF	40M Ω 1pF

HARDWARE DESCRIPTION

The high voltage input signal connects to the sensor via two clamp cage connectors. Use appropriate wire jacket and gauge, as well as creepage distance. For superior noise immunity, it is recommended to use a twisted pair from the high voltage source to the input of the sensor.

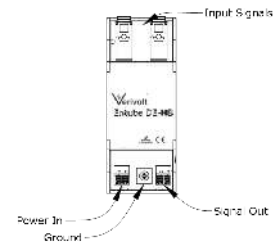

Connections for Entube DE-HB

A spring cage connector is used to input power to the sensor. A single post screw terminal is used to ground the secondary side of the sensor. The signal out of the sensor comes in a BNC connector (single-ended version), or a spring cage connector (differential-pair version). If signal reflections are a concern, place the sensor as close as possible to the high voltage signal source, and use the appropriate cable and load termination. If using a digitizer with BNC inputs, use a 50 Ω coaxial cable and a 50 Ω terminating load at the digitizer end. If using a digitizer with differential inputs, use a 100 Ω twisted pair and a 100 Ω terminating load at the digitizer end.

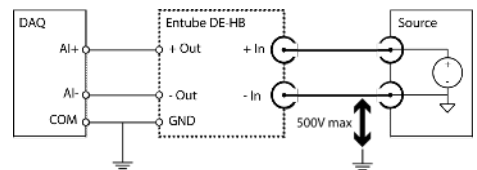

The schematic on the figure above shows how to connect the Entube-DE-HB between the high voltage signal source and the digitizer.

Electrical	
Accuracy (percentage of reading)	$\pm 0.2\%$
Max total phase shift at 60Hz	< 0.001°
Max Input delay	< 20 ns
Withstanding common mode surge voltage	4x Input Range for 0.1s
Withstanding differential mode surge voltage	5x Input Range for 0.1s
Mechanical	
Mounting Type	DIN Rail
Connectivity In	Spring cage
Connectivity Out	Spring cage / BNC
Outer Dimensions	3.6" x 2.4" x 1.4"
Weight	198 g (7.0 oz)

Performance	
Input-Output non-linearity	< 80 ppm
Output voltage	See notes
Gain temperature drift	± 40 ppm/°C
Common mode rejection at 60Hz	82 dB
Power Supply Voltage	8V to 28V
Output type	Single-ended or differential pair
Output Offset Voltage	< $\pm 0.5mV$ (on $\pm 10V$ signal)
Output impedance	50 Ω (-S) , 100 Ω (-D)
Environmental	
Operating temperature	- 0 to 70 °C
Storage temperature	- 65 to 90 °C

MERCHICAL DIMENSIONS

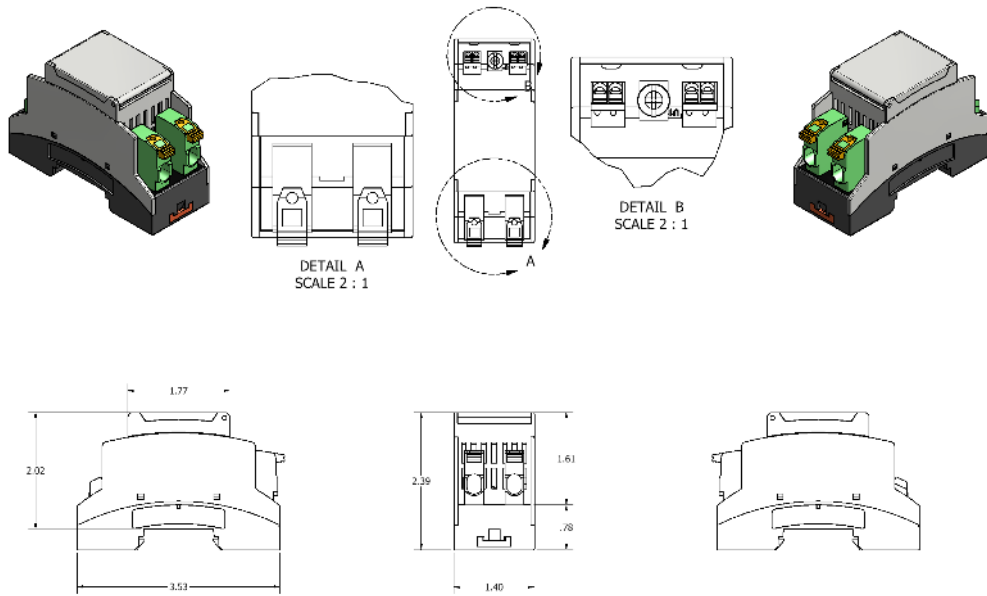

HARDWARE CONFIGURATION

A. Ground sensor by connecting a wire from the ground to the standoff located next to the two spring connectors. Connect any 8V to 28V external power source to power the unit.

B. Insert a wire pair between each of these connectors and a corresponding current input on the DAQ. The polarity of the signal out is aligned with the input signals.

C. On the primary side, connect the plus and minus signals. Use standard twisted pair.

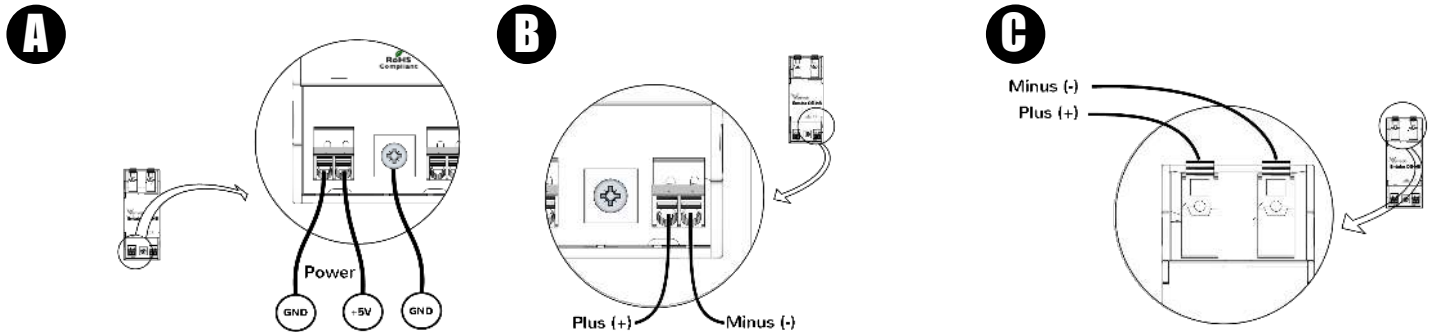

Standards and Certifications

• CE



⚠ DANGER

THIS SENSOR IS NOT A SAFETY DEVICE AND IS NOT INTENDED TO BE USED AS A SAFETY DEVICE. This sensor is designed only to detect and read certain data in an electronic manner and perform no use apart from that, specifically no safety-related use. This sensor product does not include self-checking redundant circuitry, and the failure of this sensor product could cause either an energized or de-energized output condition, which could result in death, serious bodily injury, or property damage.