



EVQ6524-R-00A

28V, 0.9A Quad Half-Bridge Motor Driver Evaluation Board

DESCRIPTION

The EVQ6524-R-00A is an evaluation board for the MPQ6524, a four half-bridge DMOS output driver with integrated power MOSFETs. It can drive up to four different loads. The input voltage ranges from 7V to 28V, with the up to 0.9A output current capability.

The four half-bridges of MPQ6524 can be controlled separately from a standard serial data interface, and have various diagnostic functions. It has very low quiescent current in standby mode makes a wide range of applications possible.

Fully protection includes short-circuit protection, under-voltage protection and thermal shutdown.

ELECTRICAL SPECIFICATION

Parameter	Symbol	Value	Units
Input Voltage	V_{IN}	7-28	V
Output Current	I_o	0.9	A

FEATURES

- Wide 7V to 28V Operating Input Range
- Up to 0.9A Output Current for Each Channel
- Total Max Current 2.4A (all outputs combined)
- R_{dson} (HS + LS) Typically 1.1Ω at 25°C , Maximum 2Ω at 150°C
- Very Low Quiescent Current $I_{VS} < 6\mu\text{A}$ in Standby Mode Versus Total Temperature Range
- Serial Data Interface
- Short-Circuit Protection
- Under-Voltage Protection
- Available in AEC-Q100 Grade 1

APPLICATIONS

- Drive various loads in automotive and industrial applications
- DC Motors

All MPS parts are lead-free, halogen-free, and adhere to the RoHS directive. For MPS green status, please visit the MPS website under Quality Assurance. "MPS" and "The Future of Analog IC Technology" are registered trademarks of Monolithic Power Systems, Inc.

EVQ6524-R-00A EVALUATION BOARD



(L × W × H) 9.73cm x 7.16cm x 1cm

Board Number	MPS IC Number
EVQ6524-R-00A	MPQ6524GR

EVALUATION BOARD SCHEMATIC

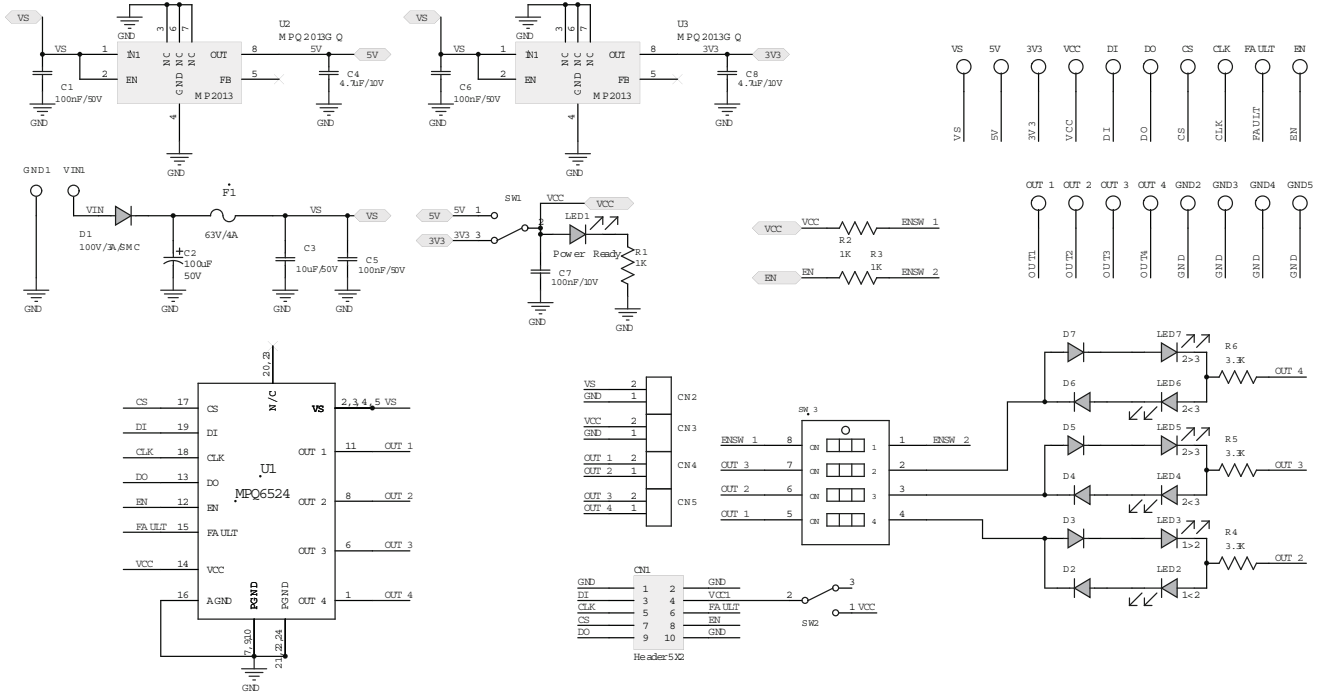

EVQ6524-R-00A BILL OF MATERIALS

Qty	RefDes	Value	Description	Package	Manufacturer	Manufacturer P/N
18	5V, 3.3V, CLK, CS, DI, DO, EN, FAULT, GND2, GND3, GND4, GND5, OUT1, OUT2, OUT3, OUT4, VCC, VS1		Test Point			
2	C4, C8	1µF/10V	Ceramic Capacitor;10V;X7R	0603	Wurth	885012206026
4	C1, C5, C6, C7	100nF/50V	Ceramic Capacitor;50V;X7R	0603	muRata	GCJ188R71H104KA12D
1	C2	330µF/35V	Electrolytic Capacitor;35V;Electrolytic;SMD	SMD	Jianghai	VZ1-35V330
1	C3	10µF/50V	Capacitor;50V	1210	muRata	GRM32ER71H106KA12L
1	CN1		Header, 5x2-Pin, Dual row			
3	CN2, CN3, CN4		CONN/2PIN/2MM, Connector			
1	D1	B340	Diode;40V;3A;	SMC	Diodes	B340
6	D2, D3, D4, D5, D6, D7	1N4148W	Diode;75V;0.15A;	SOD-123	Diodes	1N4148W
1	F1	CC12H4A	Fuse;63V;4A;	1206	COOPER	CC12H4A
2	GND,VIN		Connector, 2mm needle			
7	LED1, LED2, LED3, LED4, LED5, LED6, LED7	BL-HUF35A-TRB	LED;Red;	0805	BRIGHT LED	BL-HUF35A-TRB
1	R1	1K	Film Res., 1%	0603	Yageo	RC0603FR-071KL
2	R2, R3	10K	Film Res., 1%	0603	Yageo	RC0603FR-0710KL
3	R4, R5, R6	3.3K	Film Resistor;1%	1206	Yageo	RC0603FR-071KL
1	SW1		Botton			
1	SW3	4-bit	4-bit dial switch	SMD	Wurth	418121270805
1	SW2	NS				
1	U1	NS				
1	U3	MPQ2013A GQ-33-Z	3.3V LDO		MPS	MPQ2013AGQ-33-Z
1	U2	MPQ6524	Quad half-bridge motor driver with serial input control	QFN4X4	MPS	MPQ6524GR

PRINTED CIRCUIT BOARD LAYOUT

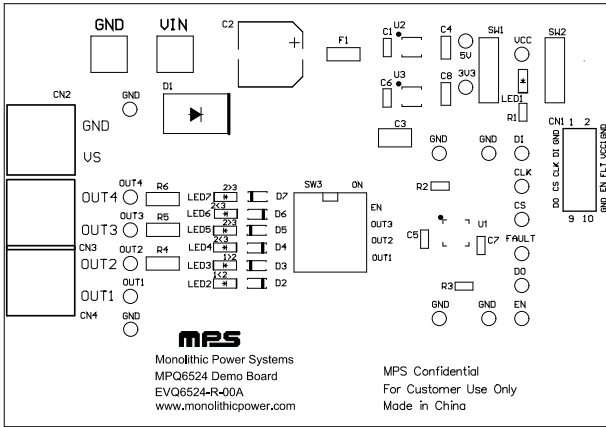

Figure 1: Top Silkscreen Layer

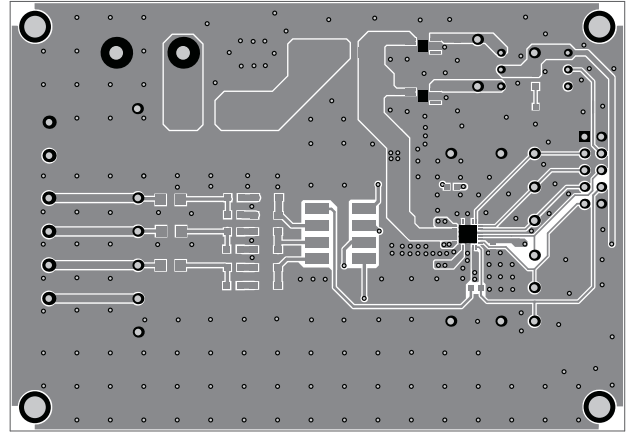

Figure 2: Top Layer

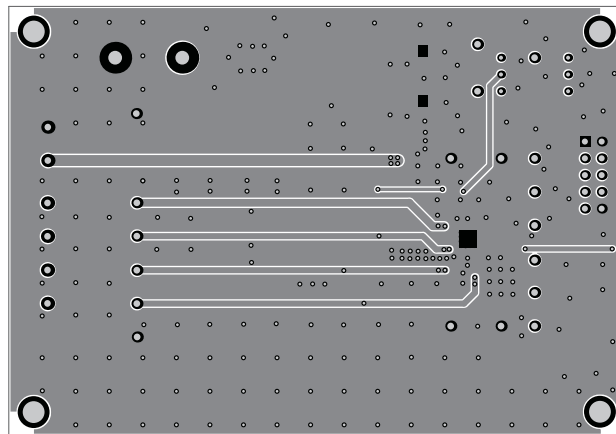

Figure 3: Bottom Layer

QUICK START GUIDE

1. Power Requirements

- a. Power supply range: 7V to 28V.

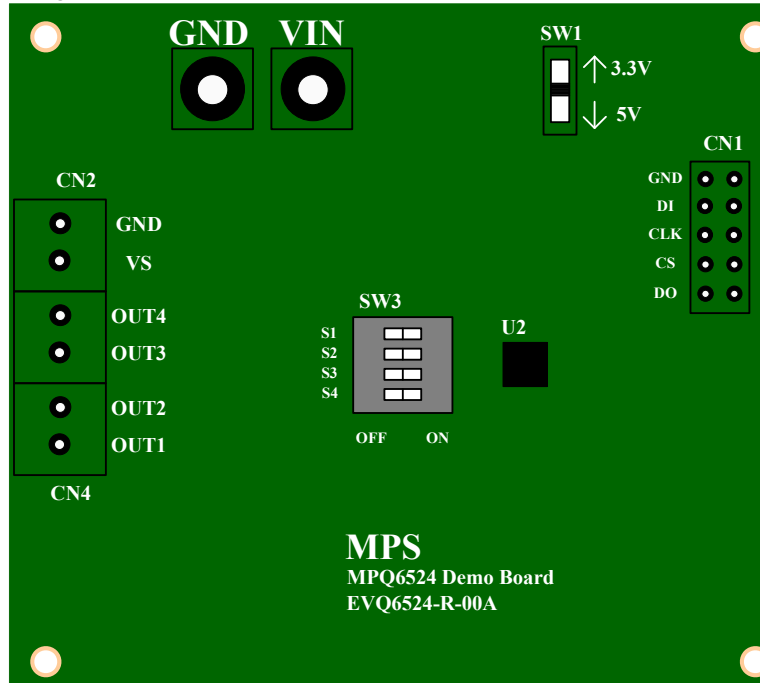

Figure 4: EVQ6524-R-00A Bird's-eye View

2. Setup Condition

- a. Adjust the power supply VIN with recommended operating range (7V to 28V).
- b. Input for VCC power supply is on board (switch SW1 upwards to select 3.3V logic supply).
- c. Easy adaptation of loads by CN2 – CN4.
- d. EN alternatively connected to VCC or GND, selected by S1 of SW3.
- e. Serial data interface control via CN1 connector.

3. Monitors

- a. For full-bridge application, indicate rotation direction of DC motors can be observed by LEDs if S2 – S4 of SW3 switch to ON position.
- b. All pins are easy accessible via test points.
- c. A low output at FAULT indicates that the IC has detected an over-temperature or over-current condition.

NOTICE: The information in this document is subject to change without notice. Users should warrant and guarantee that third party Intellectual Property rights are not infringed upon when integrating MPS products into any application. MPS will not assume any legal responsibility for any said applications.