

Verpackt im Gurt in Anlehnung an DIN IEC 60286-3
 tape on reel packaging according to DIN IEC 60286-3
 Verpackungseinheit: 280 Stück
 packaging unit: 280 pcs

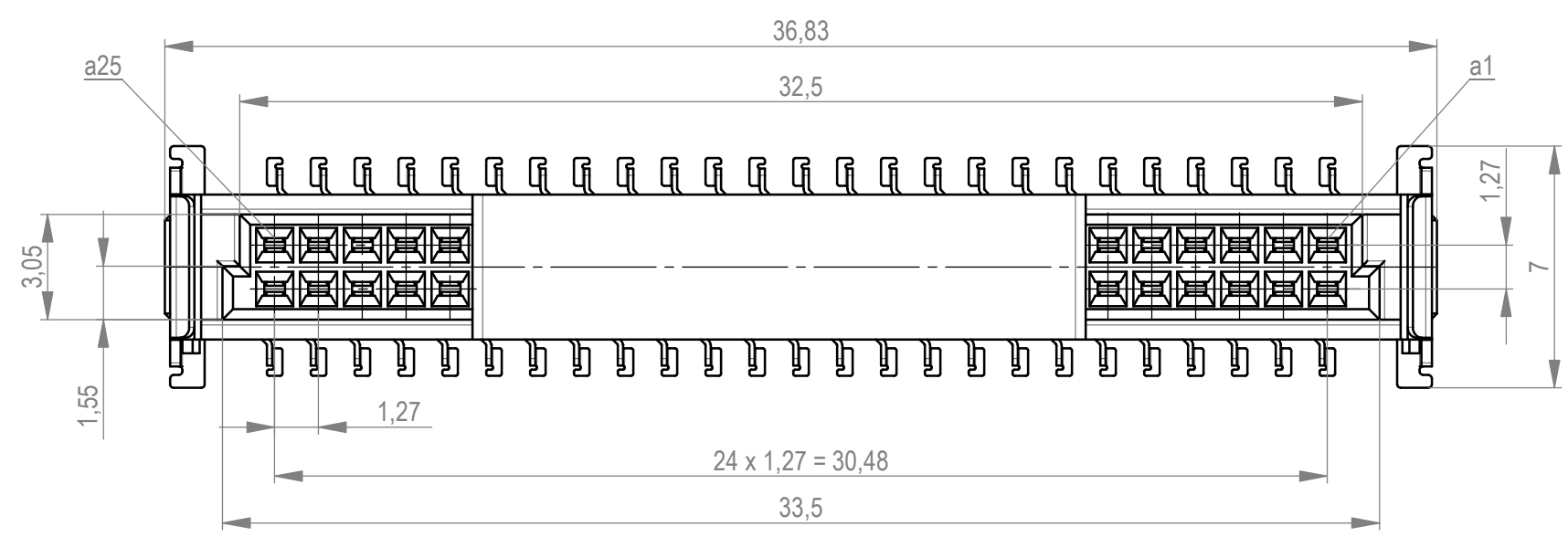

Abspulrichtung - reel off direction →

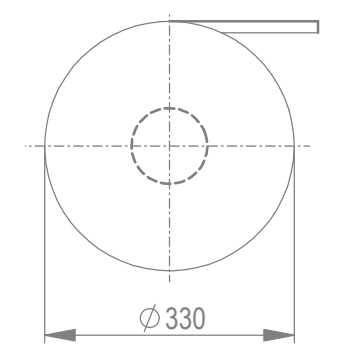
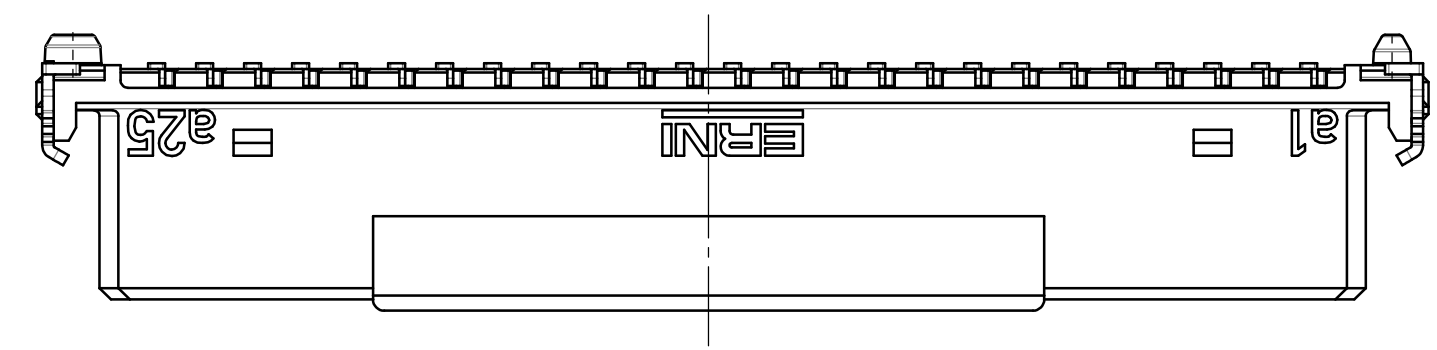
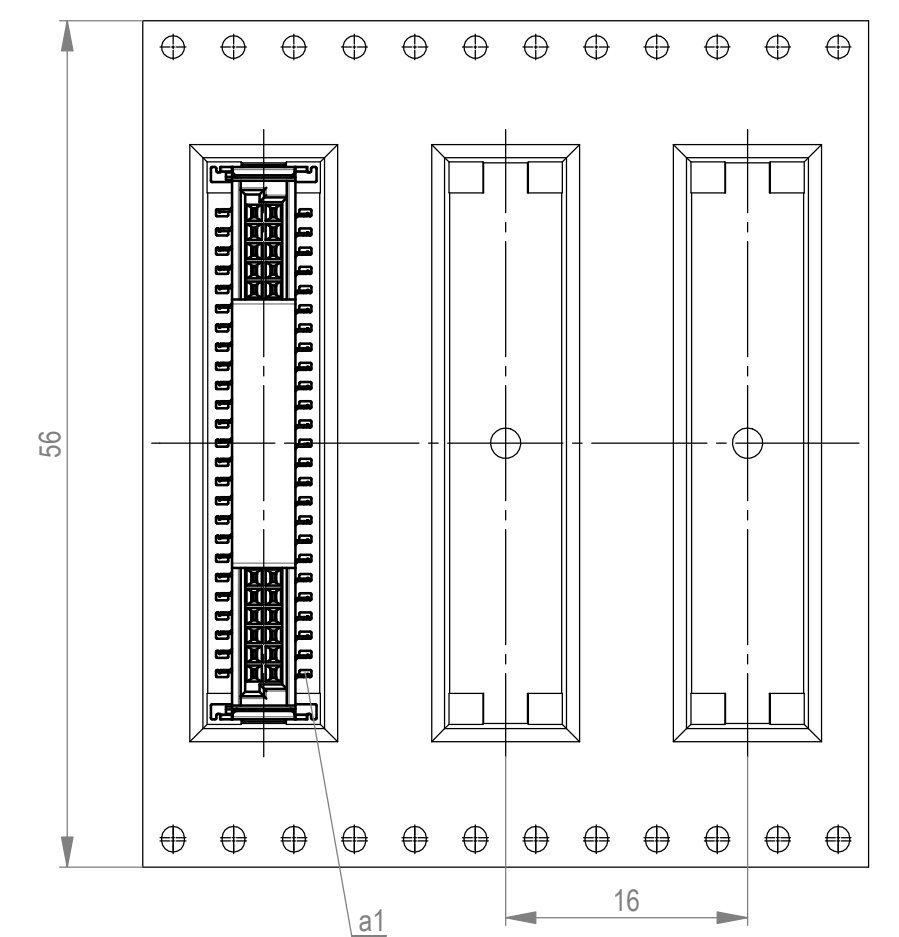

Leiterplatten-Layout Vorschlag für SMT
 PCB-Layout Proposal for SMT

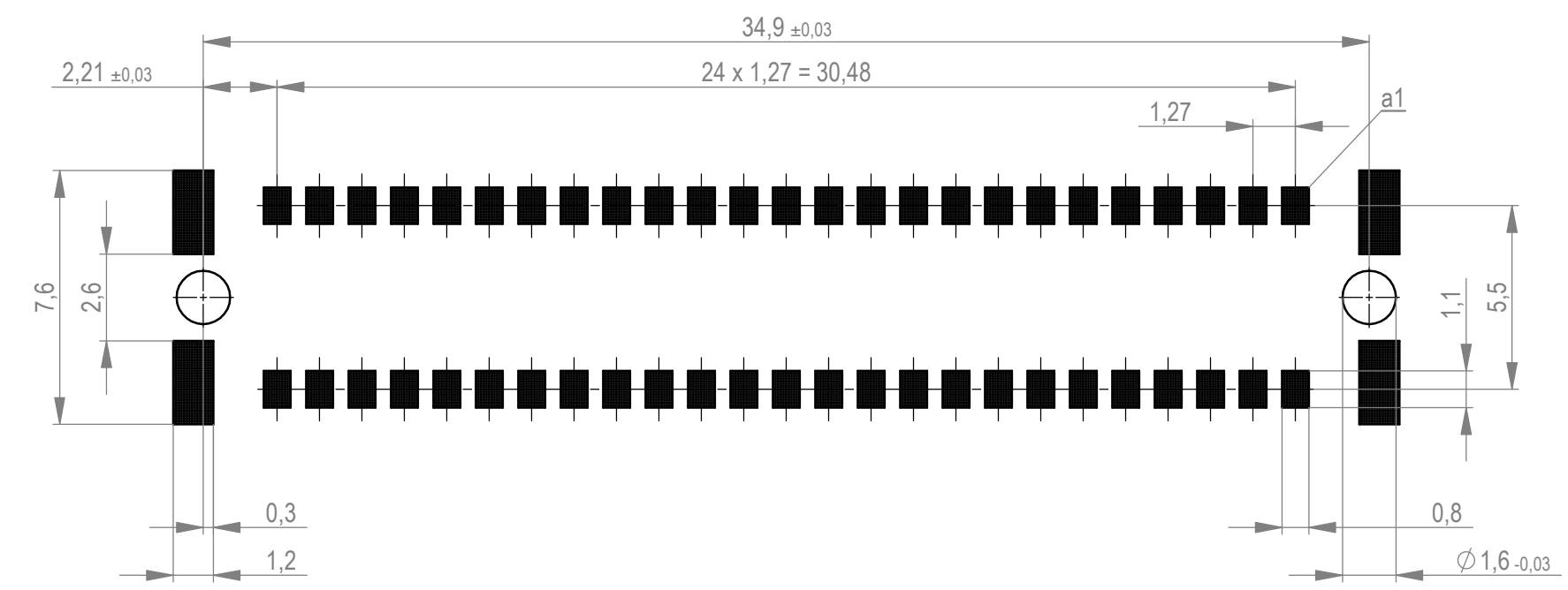

Anforderungsstufe 1
 performance level 1
 Kontaktbereich vergoldet
 mating area gold plated
 Anschlussbereich verzinkt 4-6 µm
 terminal area 4-6 µm tin plating
 Koplanarität der Anschlüsse ≤ 0,1 mm
 coplanarity area of termination ≤ 0,1 mm

BA 7-13 - 8mm Bauhöhe
 type7-13 - Low Profile

Dimension no.	Tolerances	Scale	5:1
	ISO 8015	Material	
Customer drawing:	Subject to modification without prior notice. Drawing will not be updated.		
All rights reserved. Only for information. To ensure that this is the latest version of this drawing, please contact one of the ERNI companies before using.	ERNI International AG Zürichstrasse 72 8306 Brüttisellen - Zürich Switzerland		SMC Female Straight B Type7-13 SMT 50p. Low Prof. 154807 I A2
g	08.06.2021		
Index	Date	Class	SMCB

Die deutsche Version dieser Zeichnung dient nur zur Erleichterung der Handhabung. Bei Abweichungen vom englischen Original gilt das englische Original. This drawing has been created for convenience only and may deviate from the original. In case of any deviation the English version shall prevail.