

List of "SFW__R-3/4STE5LF" customer document

DOCUMENT NO.	LIST
10102592(SHEET1)	DOCUMENT LIST
10102592(SHEET2)	CAT. NO. TABLE FOR 1mm SPACING SMT CONNECTOR (SFW__R-3/4ST__LF)
10102592(SHEET3)	1mm SPACING SMT CONNECTOR (SFW__R-3ST__LF)
10102592(SHEET4)	1mm SPACING SMT CONNECTOR (SFW__R-4ST__LF)
10102592(SHEET5)	CAT. NO. TABLE FOR PLASTIC TAPE PACKAGED 1mm SPACING SMT CONNECTOR (SFW__R-3/4STE5LF)
10102592(SHEET6)	PLASTIC TAPE PACKAGED 1mm SPACING SMT CONNECTOR (SFW__R-3STE5LF)
10102592(SHEET7)	PLASTIC TAPE PACKAGED 1mm SPACING SMT CONNECTOR (SFW__R-4STE5LF)
10102592(SHEET8)	RECOMMENDED CABLE (FPC) (SFW__R-3/4ST__)
10102592(SHEET9)	RECOMMENDED CABLE (FFC) (SFW__R-3/4ST__)
SC-SFW11	PRODUCT SPECIFICATION
GS-20-130	HANDLING PROCEDURES



© 2016 AFCl

mat'l. code				surface		tolerance				projection		product family			
-				ISO 1302		ISO 406 ISO 1101						58RF			
ltr	ecn no	dr	date	tolerances unless otherwise specified		angles		linear		MM		title			
A	S09-0194	DGOH	2009-6-8									1mm SPACING SMT CONNECTOR DOCUMENT LIST (Cat. No. : SFW__R-3/4STE5LF)			
B	J09-0380	S.W	2009-10-27												
C	ELX-J-32994	S.W	2019-3-25							scale N/A					
				dr	S.WATANABE	2019-3-25					dwg no		sheet 1 of 9		size
				enr	S.WATANABE	2019-3-25					10102592				A4
				chr	S-H.THIO	2019-3-25									
				appd	Y.KAMEDA	2019-3-25									
sheet index		revision sheet	C	C	C	C	C	C	C	C	C	type Product Customer Drawing			
			1	2	3	4	5	6	7	8	9				

CAT. NO. & DIMENSIONS

NO. OF CONTACTS (n)	CAT. NO.	DIMENSIONS (NOTE2)			
		A ± 0.2	B ± 0.2	C ± 0.2	D ± 0.1
4	SFW4R-3/4ST__LF	9.8	8.6	3.0	3.92
5	SFW5R-3/4ST__LF	10.8	9.6	4.0	4.92
6	SFW6R-3/4ST__LF	11.8	10.6	5.0	5.92
7	SFW7R-3/4ST__LF	12.8	11.6	6.0	6.92
8	SFW8R-3/4ST__LF	13.8	12.6	7.0	7.92
9	SFW9R-3/4ST__LF	14.8	13.6	8.0	8.92
10	SFW10R-3/4ST__LF	15.8	14.6	9.0	9.92
11	SFW11R-3/4ST__LF	16.8	15.6	10.0	10.92
12	SFW12R-3/4ST__LF	17.8	16.6	11.0	11.92
13	SFW13R-3/4ST__LF	18.8	17.6	12.0	12.92
14	SFW14R-3/4ST__LF	19.8	18.6	13.0	13.92
15	SFW15R-3/4ST__LF	20.8	19.6	14.0	14.92
16	SFW16R-3/4ST__LF	21.8	20.6	15.0	15.92
17	SFW17R-3/4ST__LF	22.8	21.6	16.0	16.92
18	SFW18R-3/4ST__LF	23.8	22.6	17.0	17.92
19	SFW19R-3/4ST__LF	24.8	23.6	18.0	18.92
20	SFW20R-3/4ST__LF	25.8	24.6	19.0	19.92
21	SFW21R-3/4ST__LF	26.8	25.6	20.0	20.92
22	SFW22R-3/4ST__LF	27.8	26.6	21.0	21.92
23	SFW23R-3/4ST__LF	28.8	27.6	22.0	22.92
24	SFW24R-3/4ST__LF	29.8	28.6	23.0	23.92
25	SFW25R-3/4ST__LF	30.8	29.6	24.0	24.92
26	SFW26R-3/4ST__LF	31.8	30.6	25.0	25.92
27	SFW27R-3/4ST__LF	32.8	31.6	26.0	26.92
28	SFW28R-3/4ST__LF	33.8	32.6	27.0	27.92
29	SFW29R-3/4ST__LF	34.8	33.6	28.0	28.92
30	SFW30R-3/4ST__LF	35.8	34.6	29.0	29.92

CAT. NO. SFW (n) R - 3 ST __ LF

SERIES NAME

NO. OF CONTACTS

RIGHT ANGLE TYPE

FOR FPC/FFC, WITH CABLE LOCK MECHANISM

CONTACT DIRECTION

3. LOWER CONTACT TYPE

4. UPPER CONTACT TYPE

FOR AUTOMATIC MOUNTING (SMT)

PACKAGE STYLE

LEAD FREE

NOTES

1. THIS PRODUCT IS THE CONNECTOR USED FOR FPC/FFC AND COPEs WITH AUTOMATIC MOUNTING (SMT).
2. SEE PART DRAWINGS FOR DIMENSIONS A~D.
3. THIS PRODUCT IS THE CONNECTOR WITH CABLE LOCK MECHANISM.

mat'l. code				surface ISO 1302 <input checked="" type="checkbox"/>		tolerance ISO 406 ISO 1101		projection		product family 58RF			
ltr	ecn no	dr	date	tolerances unless otherwise specified				MM		title CAT NO. TABLE FOR 1mm SPACING SMT CONNECTOR (Cat. No. SFW__R-3/4ST__LF)			
c				angles	linear			scale N/A		dwg no		sheet 2 of 9	size
				dr	S.WATANABE	2019-3-25				10102592		A4	
				enr	S.WATANABE	2019-3-25							
				chr	S-H.THIO	2019-3-25							
				appd	Y.KAMEDA	2019-3-25							
sheet index		revision sheet											

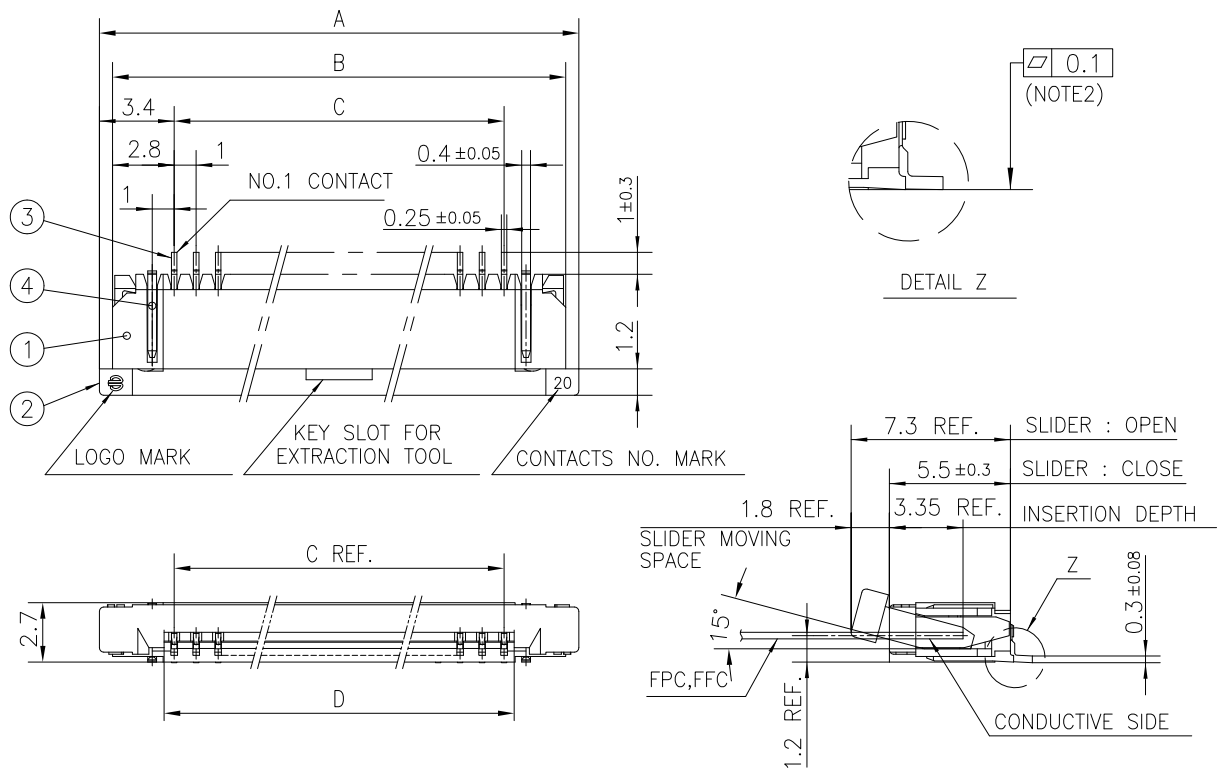

PT. NO.	PARTS NAME	MATERIAL	Q'TY	NOTE
1	HOUSING	PPS RESIN GLASS REINFORCED (UL94V-0)	1	COLOR : BLACK
2	SLIDER		1	COLOR : BROWN
3	CONTACT	PHOSPHOR BRONZE	n	PLATING : TIN
4	MOUNTING PLATE		2	

n : NO. OF CONTACTS

RECOMMENDED PC BOARD LAYOUT
(COMPONENT SIDE)

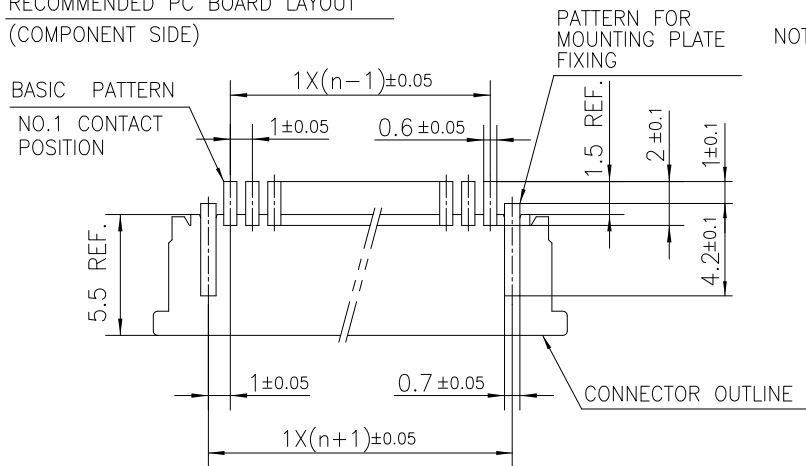

NOTES

1. THIS PRODUCT IS THE CONNECTOR USED FOR FPC/FFC AND COPES WITH AUTOMATIC MOUNTING (SMT).
2. FLATNESS FOR CONTACT TERMINAL HOUSING MUST BE WITHIN TOLERANCE IN Z PORTION DETAILED DRAWING.
3. THIS PRODUCT IS LOWER CONTACT TYPE CONNECTOR WITH CABLE LOCK MECHANISM.
4. THIS PRODUCT MEETS EUROPEAN UNION DIRECTIVES AND OTHER COUNTRY REGULATIONS AS DESCRIBED IN GS-22-008.
5. THE HOUSING WILL WITHSTAND EXPOSURE TO 260°C PEAK TEMPERATURE FOR 10 SECONDS IN A REFLOW SOLDERING OVEN.

mat'l. code		surface ISO 1302		tolerance ISO 406 ISO 1101		projection		product family	
-		✓						58RF	
ltr	ecn no	dr	date	tolerances unless otherwise specified				title	
c				angles linear ±0.2		MM		1mm SPACING SMT CONNECTOR (Cat. No. SFW__R-3ST__LF)	
		dr	S.WATANABE	2019-3-25				dwg no sheet 3 of 9 size	
		enr	S.WATANABE	2019-3-25				10102592 A4	
		chr	S-H.THIO	2019-3-25					
		appd	Y.KAMEDA	2019-3-25				type Product Customer Drawing	
sheet index	revision sheet								

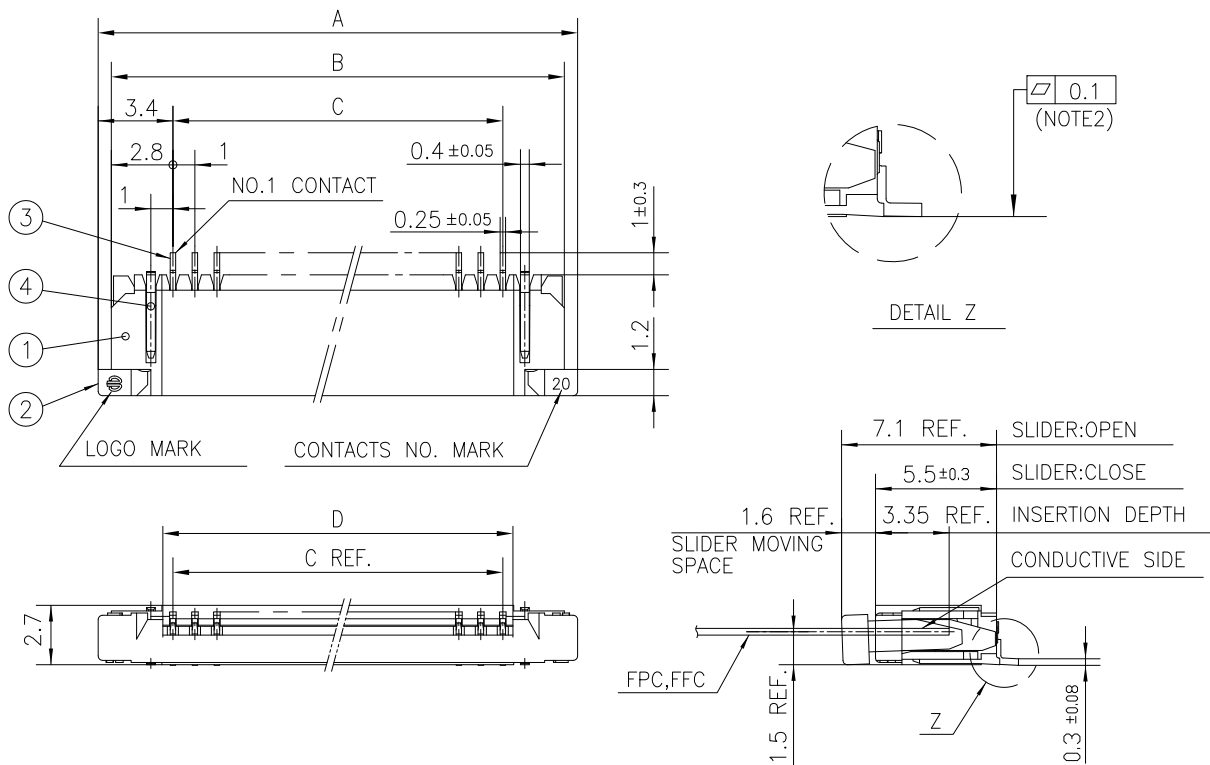

PT. NO.	PARTS NAME	MATERIAL	Q'TY	NOTE
1	HOUSING	PPS RESIN GLASS REINFORCED (UL94V-0)	1	COLOR : BLACK
2	SLIDER		1	COLOR : BROWN
3	CONTACT	PHOSPHOR BRONZE	n	PLATING : TIN
4	MOUNTING PLATE		2	

n : NO. OF CONTACTS

RECOMMENDED PC BOARD LAYOUT (COMPONENT SIDE)

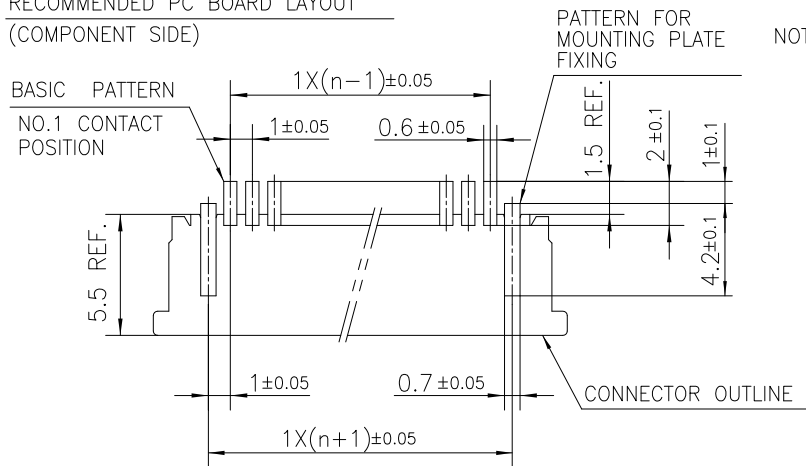

NOTES

1. THIS PRODUCT IS THE CONNECTOR USED FOR FPC/FFC AND COPES WITH AUTOMATIC MOUNTING (SMT).
2. FLATNESS FOR CONTACT TERMINAL HOUSING MUST BE WITHIN TOLERANCE IN Z PORTION DETAILED DRAWING.
3. THIS PRODUCT IS UPPER CONTACT TYPE CONNECTOR WITH CABLE LOCK MECHANISM.
4. THIS PRODUCT MEETS EUROPEAN UNION DIRECTIVES AND OTHER COUNTRY REGULATIONS AS DESCRIBED IN GS-22-008.
5. THE HOUSING WILL WITHSTAND EXPOSURE TO 260°C PEAK TEMPERATURE FOR 10 SECONDS IN A REFLOW SOLDERING OVEN.

mat'l. code		surface ISO 1302		tolerance ISO 406 ISO 1101		projection		product family			
ltr		ecn no		dr		date		tolerances unless otherwise specified		title	
c								angles linear ±0.2		1mm SPACING SMT CONNECTOR (Cat. No. SFW__R-4ST__LF)	
								scale		dwg no	
				dr		S.WATANABE		2019-3-25		sheet 4 of 9	
				enr		S.WATANABE		2019-3-25		size	
				chr		S-H.THIO		2019-3-25		A4	
				appd		Y.KAMEDA		2019-3-25		type Product Customer Drawing	
sheet index		revision sheet									

CAT. NO. & DIMENSIONS

NO. OF CONTACTS (n)	CAT. NO. (NOTE2)	DIMENSIONS (NOTE3)		
		E MAX.	F ± 0.3	G ± 0.1
4	SFW4R-3/4STE5LF	22.4	16	—
5	SFW5R-3/4STE5LF	30.4	24	—
6	SFW6R-3/4STE5LF	30.4	24	—
7	SFW7R-3/4STE5LF	30.4	24	—
8	SFW8R-3/4STE5LF	30.4	24	—
9	SFW9R-3/4STE5LF	30.4	24	—
10	SFW10R-3/4STE5LF	30.4	24	—
11	SFW11R-3/4STE5LF	30.4	24	—
12	SFW12R-3/4STE5LF	30.4	24	—
13	SFW13R-3/4STE5LF	38.4	32	28.4
14	SFW14R-3/4STE5LF	38.4	32	28.4
15	SFW15R-3/4STE5LF	38.4	32	28.4
16	SFW16R-3/4STE5LF	38.4	32	28.4
17	SFW17R-3/4STE5LF	50.4	44	40.4
18	SFW18R-3/4STE5LF	50.4	44	40.4
19	SFW19R-3/4STE5LF	50.4	44	40.4
20	SFW20R-3/4STE5LF	50.4	44	40.4
21	SFW21R-3/4STE5LF	50.4	44	40.4
22	SFW22R-3/4STE5LF	50.4	44	40.4
23	SFW23R-3/4STE5LF	50.4	44	40.4
24	SFW24R-3/4STE5LF	50.4	44	40.4
25	SFW25R-3/4STE5LF	50.4	44	40.4
26	SFW26R-3/4STE5LF	50.4	44	40.4
27	SFW27R-3/4STE5LF	50.4	44	40.4
28	SFW28R-3/4STE5LF	62.4	56	52.4
29	SFW29R-3/4STE5LF	62.4	56	52.4
30	SFW30R-3/4STE5LF	62.4	56	52.4

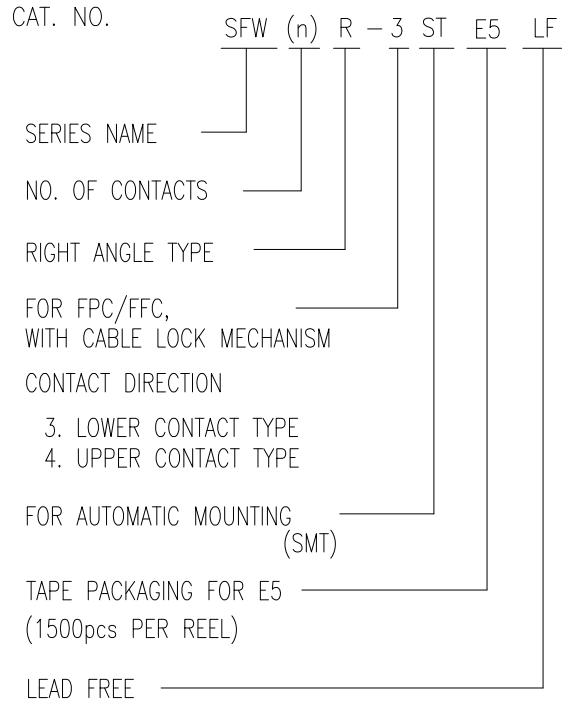

NOTES

1. THIS PRODUCT IS THE CONNECTOR USED FOR FPC/FFC AND COPEs WITH AUTOMATIC MOUNTING (SMT).
2. THIS CATALOG NO. INDICATES PLASTIC TAPE PACKAGED CONNECTOR.
3. SEE PART DRAWINGS FOR DIMENSIONS E~G.
4. THIS PRODUCT IS THE CONNECTOR WITH CABLE LOCK MECHANISM.

mat'l. code		surface ISO 1302 <input checked="" type="checkbox"/>		tolerance ISO 406 ISO 1101		projection		product family 58RF	
ltr	ecn no	dr	date	tolerances unless otherwise specified		MM		title	
c				angles	linear	scale N/A		CAT NO. TABLE FOR PLASTIC TAPE PACKAGED 1mm SPACING SMT CONNECTOR (Cat. No. SFW__R-3/4STE5LF)	
				dr	S.WATANABE	2019-3-25		dwg no sheet 5 of 9 size	
				enr	S.WATANABE	2019-3-25		10102592 A4	
				chr	S-H.THIO	2019-3-25			
				appd	Y.KAMEDA	2019-3-25		type Product Customer Drawing	
sheet index	revision sheet								

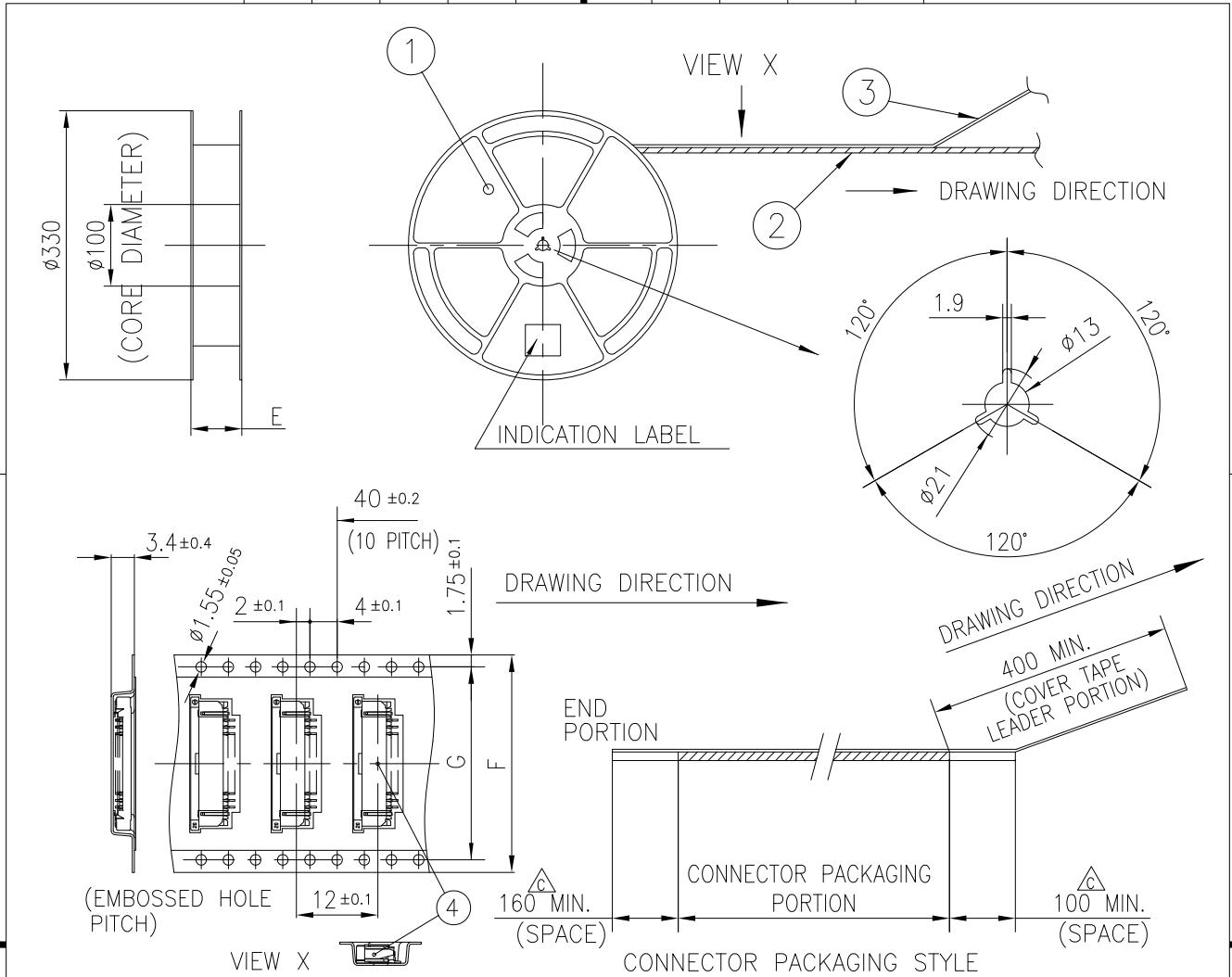

PT. NO.	PARTS NAME	CAT. NO.	MATERIAL	Q'TY	NOTE
1	REEL	_____	POLYSTYRENE	1	COLOR : WHITE or Black
2	PLASTIC (EMBOSS) TAPE	_____	△ PS or A-PET	_____	COLOR:TRANSPARENCY
3	COVER	_____	△ POLYESTER,POLYETHYLENE	_____	COLOR:TRANSPARENCY
4	CONNECTOR	SFW__R-3ST__LF	SEE SHEET3	1500	LOWER CONTACT TYPE

NOTES

1. THIS IS PLASTIC TAPE PACKAGED CONNECTOR WITH CABLE LOCK MECHANISM USED FOR FPC/FFC AND COPEs WITH AUTOMATIC MOUNTING (SMT).
2. SEE JIS C 0806 (PACKING OF ELECTRONIC COMPONENTS ON CONTINUOUS TAPES (SURFACE MOUNTING DEVICES)) FOR SHAPE AND DIMENSIONS OF PLASTIC (EMBOSS) TAPE AND REEL.
3. E DIMENSION IS PORTION OF THE CORE.

mat'l. code		surface		tolerance		projection		product family	
-		ISO 1302 ✓		ISO 406 ISO 1101				58RF	
ltr	ecn no	dr	date	tolerances unless otherwise specified				title	
c				angles	linear			PLASTIC TAPE PACKAGED 1mm SPACING SMT CONNECTOR (Cat. No. SFW__R-3STE5LF)	
				±5°	±5			dwg no sheet 6 of 9 size 10102592 A4	
				dr	S.WATANABE	2019-3-25	type		Product Customer Drawing
				enr	S.WATANABE	2019-3-25			
				chr	S-H.THIO	2019-3-25			
				appd	Y.KAMEDA	2019-3-25			
sheet index	revision sheet								

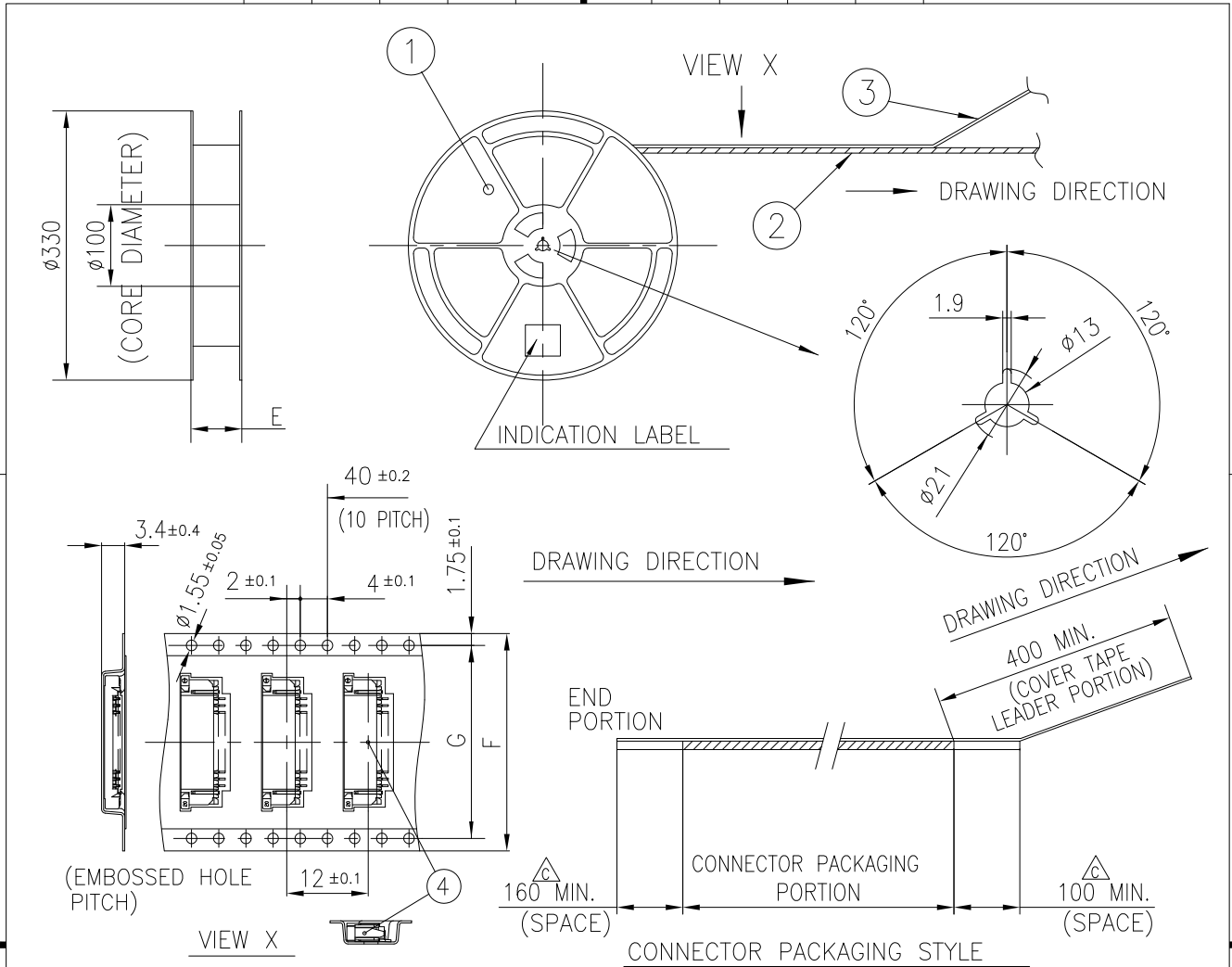

PT. NO.	PARTS NAME	CAT. NO.	MATERIAL	Q'TY	NOTE
1	REEL	—	POLYSTYRENE	1	COLOR : WHITE or Black
2	PLASTIC (EMBOSS) TAPE	—	△ PS or A-PET	—	COLOR:TRANSPARENCY
3	COVER	—	△ POLYESTER,POLYETHYLENE	—	COLOR:TRANSPARENCY
4	CONNECTOR	SFW__R-4ST__LF	SEE SHEET4	1500	UPPER CONTACT TYPE

NOTES

- THIS IS PLASTIC TAPE PACKAGED CONNECTOR WITH CABLE LOCK MECHANISM USED FOR FPC/FFC AND COPES WITH AUTOMATIC MOUNTING (SMT).
- SEE JIS C 0806 (PACKING OF ELECTRONIC COMPONENTS ON CONTINUOUS TAPES (SURFACE MOUNTING DEVICES)) FOR SHAPE AND DIMENSIONS OF PLASTIC (EMBOSS) TAPE AND REEL.
- E DIMENSION IS PORTION OF THE CORE.

mat'l. code		surface		tolerance		projection		product family			
—		ISO 1302 ✓		ISO 406 ISO 1101				58RF			
ltr	ecn no	dr	date	tolerances unless otherwise specified				title			
c				angles	±5	MM		PLASTIC TAPE PACKAGED 1mm SPACING SMT CONNECTOR (Cat. No. SFW__R-4STE5LF)			
				linear	±5	scale N/A		dwg no			
				dr	S.WATANABE	2019-3-25			sheet 7 of 9		
				enr	S.WATANABE	2019-3-25			10102592		size
				chr	S-H.THIO	2019-3-25			A4		
				appd	Y.KAMEDA	2019-3-25			type		Product Customer Drawing
sheet index	revision sheet										

RECOMMENDED CABLE (FPC)

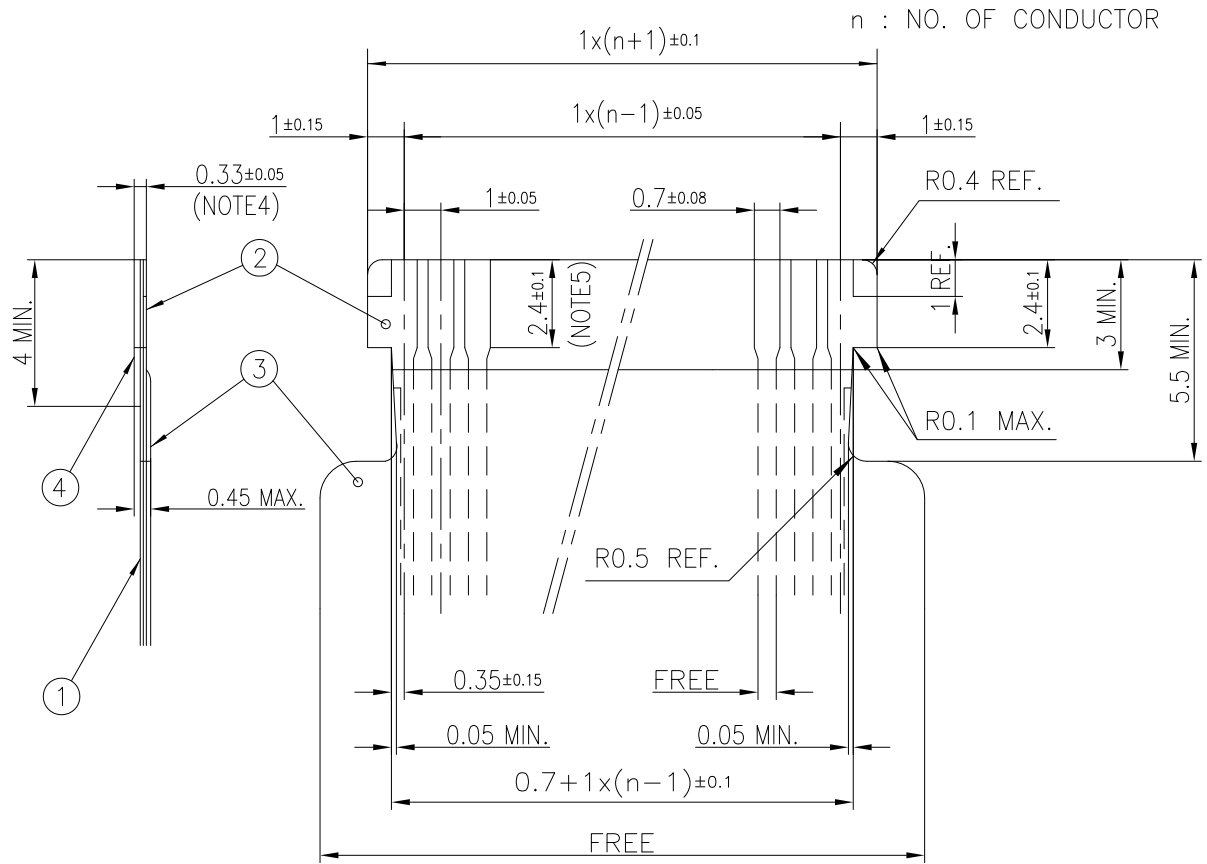

PT. NO.	PARTS NAME	MATERIAL	THICKNESS(um)
1	BASE FILM	POLYIMIDE OR POLYESTER OR EQUAL	25
2	CONDUCTOR	COPPER FOIL(PLATING: TIN OR SOLDER 1um MIN.)	35
3	OVERLAY	POLYIMIDE OR POLYESTER OR EQUAL	—
4	SUPPORTING TAPE	POLYESTER OR POLYIMIDE OR EQUAL	188

NOTES

1. THIS DRAWING INDICATES THE FPC USED THE CONNECTOR WITH CABLE LOCK MECHANISM.
2. NO BURR AT EACH PORTION.
3. NO PEELING IN COMMON USE.
4. TOTAL THICKNESS LIMIT OF EACH MATERIAL (INCLUDING ADHESIVE AGENT) IS SPECIFIED.
5. THIS DIMENSION INDICATES THE RANGE FOR 0.7±0.08 CONDUCTOR WIDTH.

mat'l. code		surface		tolerance		projection		product family		
-		ISO 1302		ISO 406 ISO 1101				58RF		
ltr	ecn no	dr	date	tolerances unless otherwise specified				title		
c				angles	linear	MM		RECOMMENDED CABLE		
						scale 5:1		(Cat. No. SFW__R-3/4ST__)		
		dr	S.WATANABE	2019-3-25				dwg no		
		enr	S.WATANABE	2019-3-25	sheet 8 of 9			size		
		chr	S-H.THIO	2019-3-25	10102592			A4		
		appd	Y.KAMEDA	2019-3-25	type Product Customer Drawing					
sheet index	revision sheet									

RECOMMENDED CABLE (FFC)

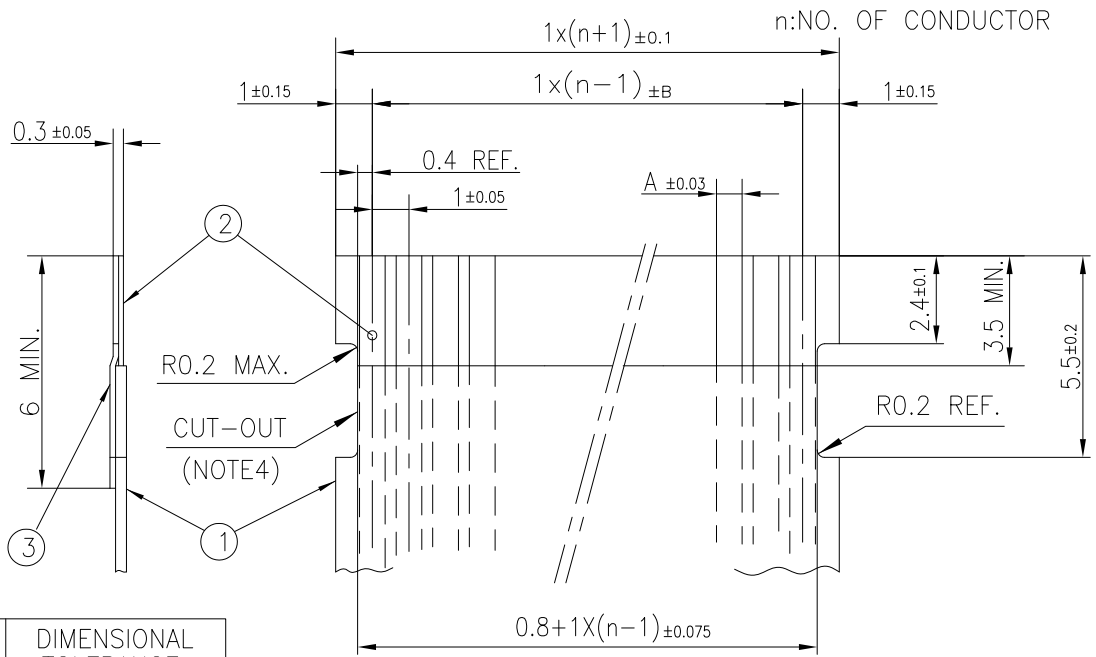

KIND OF FFC (NOTE5)	DIMENSIONAL TOLERANCE	
	A	B
1	0.7	0.1
2	0.6	0.07

PT. NO.	PARTS NAME	MATERIAL	NOTE
1	INSULATOR	FLAME RESISTING POLYESTER OR EQUAL	_____
2	CONDUCTOR	COPPER FOIL	PLATING : TIN OR SOLDER 1um MIN.
3	SUPPORTING TAPE	FLAME RESISTING POLYESTER OR EQUAL	_____

- NOTES
1. THIS DRAWING INDICATES THE FFC USED THE CONNECTOR WITH CABLE LOCK MECHANISM.
 2. NO BURR AT EACH PORTION.
 3. NO PEELING IN COMMON USE.
 4. THERE IS A POSSIBILITY THAT THE CAT-OUT CROSSES THE CONDUCTOR BECAUSE OF DIMENSIONAL TOLERANCE.
 5. EITHER KIND1 OR KIND2 OF FFC CAN ACCEPT DIMENSIONAL TOLERANCE a AND b.

mat'l. code		surface		tolerance		projection		product family	
-		ISO 1302		ISO 406 ISO 1101				58RF	
ltr	ecn no	dr	date	tolerances unless otherwise specified		MM		title	
c				angles	linear			RECOMMENDED CABLE (Cat. No. SFW__R-3/4ST__)	
				dr	S.WATANABE	2019-3-25		dwg no	
				enr	S.WATANABE	2019-3-25		sheet 9 of 9	
				chr	S-H.THIO	2019-3-25		10102592	
				appd	Y.KAMEDA	2019-3-25		A4	
sheet index		revision sheet						type Product Customer Drawing	