

THIS DRAWING IS UNPUBLISHED. RELEASED FOR PUBLICATION 20
 © COPYRIGHT 20 BY TYCO ELECTRONICS CORPORATION. ALL RIGHTS RESERVED.

LOC	DIST	REVISIONS					
GE	00	P	LTR	DESCRIPTION	DATE	DWN	APVD
		A		RELEASED PER EC 0K40-0668-02	25JUN2002	VMK	VMK
		B		REV PER EC 0K80-0298-02	13DEC2002	RGV	AME
		C		REV PER ECR 07-018498	22AUG2007	RGV	DHC

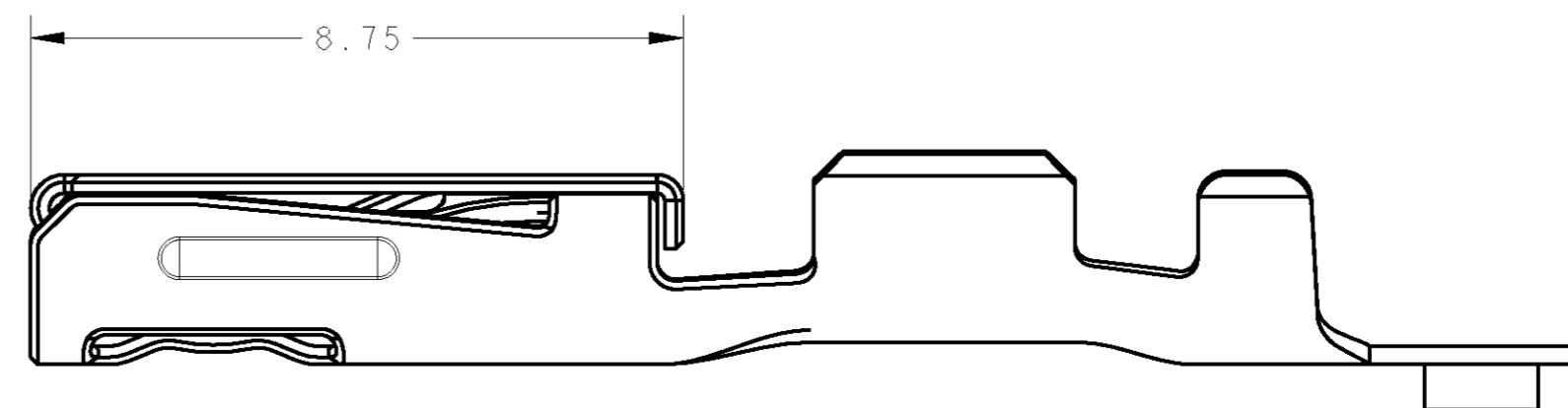

- 1 FINISH: PLATED 0.001 MIN THICK TIN.
- 2. PART LUBRICATED WITH ANTI-FRETTING LUBRICANT, MSDS 125-6344.
- 3 FEATURE ON CARRIER STRIP IS DEPRESSED ON TIN PLATED PRODUCT. FEATURE APPEARS ADJACENT TO EVERY OTHER CONTACT MIN.
- 4 SEE FIGURE 1 FOR REELING DIRECTION.
- 5 SEE FIGURE 2 FOR REELING DIRECTION.
- 6. NOTE DELETED.
- 7. NOTE DELETED.
- 8. SEE SHEET 2 FOR ADDITIONAL CRIMPING REQUIREMENTS.

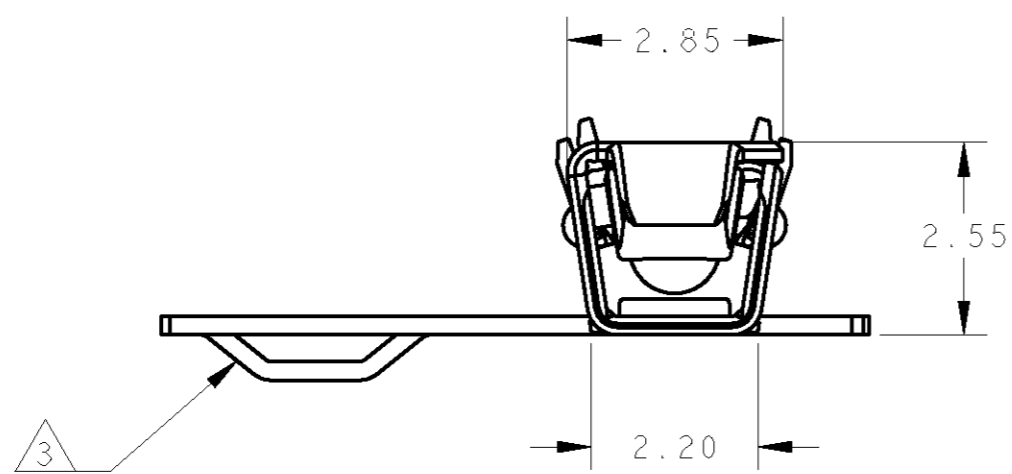
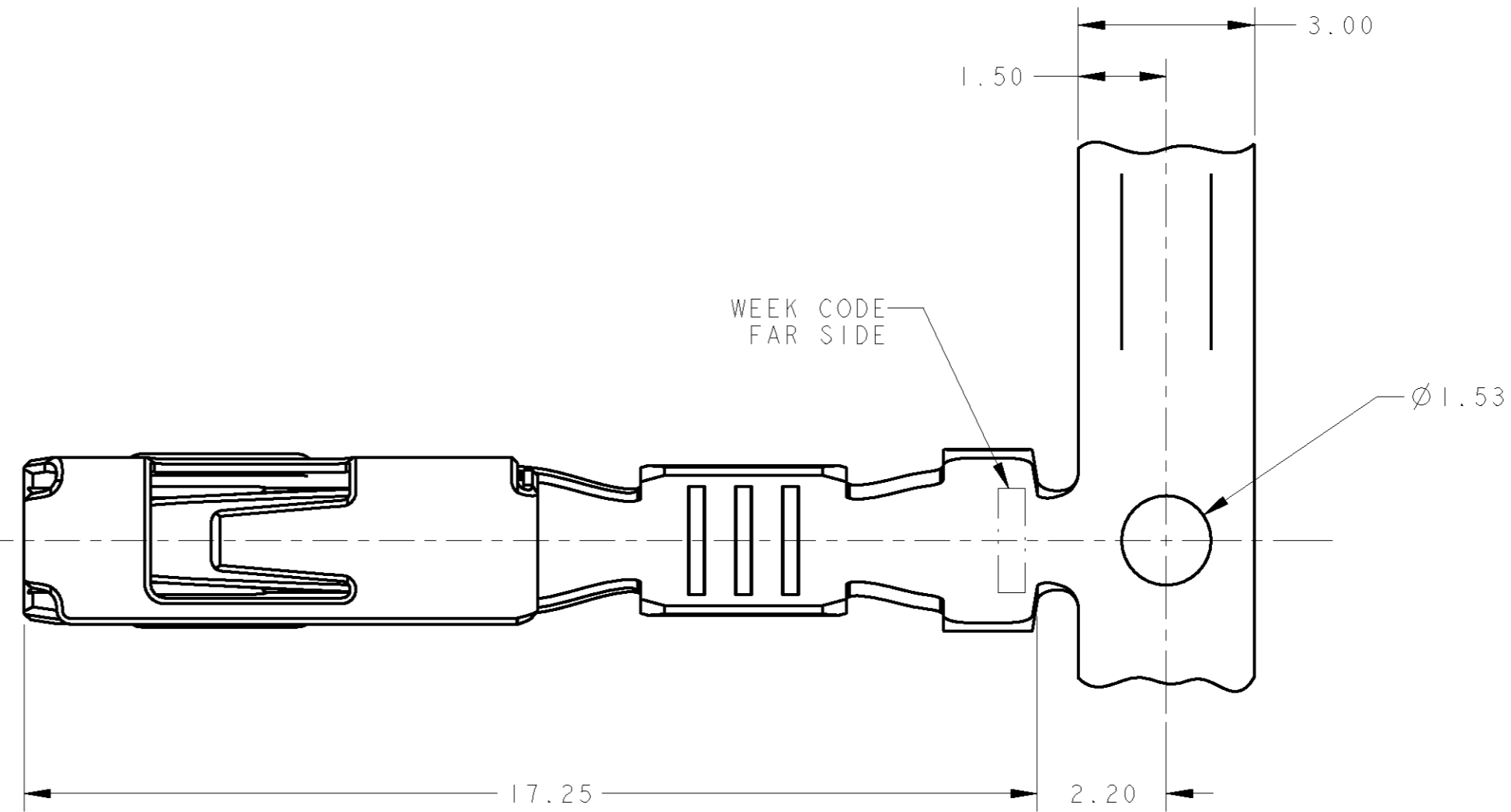
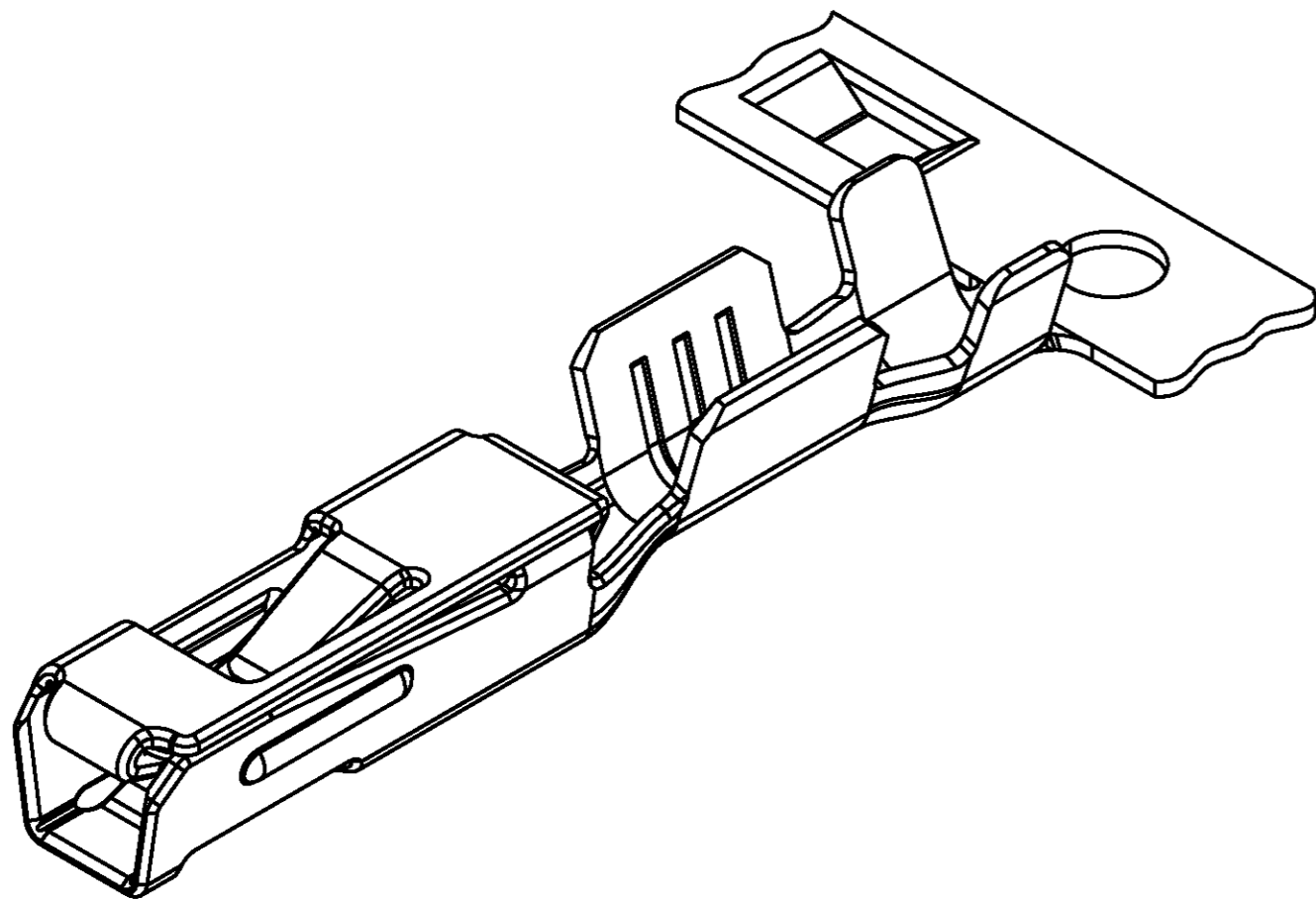
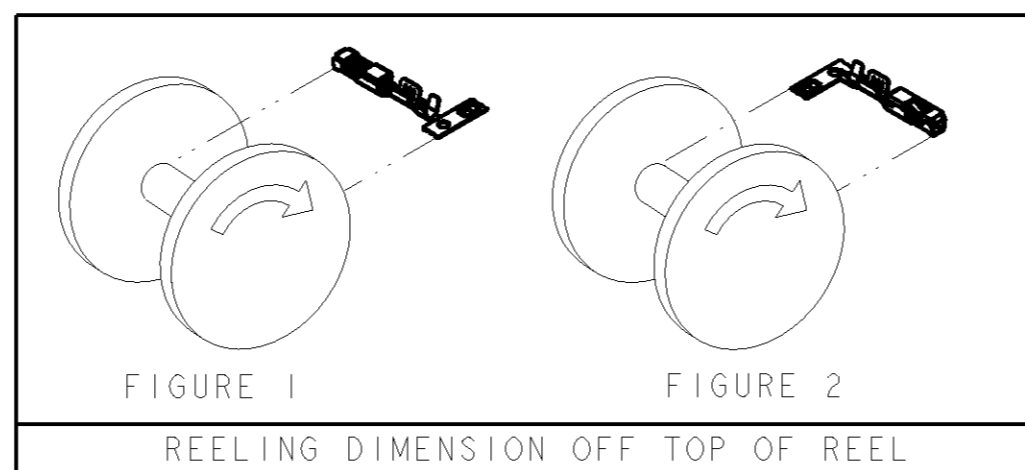

REELING	FINISH	WIRE SIZE	PART NUMBER
5	1	18-20	638652-5
		14-16	638652-4
4	1	18-20	638652-2
		14-16	638652-1

THIS DRAWING IS A CONTROLLED DOCUMENT FOR TYCO ELECTRONICS CORPORATION. IT IS SUBJECT TO CHANGE AND THE CONTROLLING ENGINEERING ORGANIZATION SHOULD BE CONTACTED FOR THE LATEST REVISION.

DWN	J. R. SHUEY	28FEB2000	Tyco Electronics Harrisburg, PA 17105-3608				
CHK	J. M. MYER	28FEB2000					
APVD	K. DENLINGER	28FEB2000					
NAME	CONTACT, FEMALE, 1.5mm, TIN PLATED						
PRODUCT SPEC	USCAR-2		SIZE	CAGE CODE	DRAWING NO	RESTRICTED TO	
REV 3 DATED APRIL 2001	APPLICATION SPEC		A2	00779	C-638652	-	
MATERIAL	0.25 THICK COPPER ALLOY		WEIGHT	-		SCALE	10:1
TOLERANCES UNLESS OTHERWISE SPECIFIED:	0 PLC ±		CUSTOMER DRAWING	-		SHEET	1
1 PLC ±	2 PLC ±0.20		-		OF	2	
3 PLC ±	4 PLC ±		-		REV	C	
ANGLES ±3°	FINISH		-				

THIS DRAWING IS UNPUBLISHED. RELEASED FOR PUBLICATION 20
 © COPYRIGHT 20 BY TYCO ELECTRONICS CORPORATION. ALL RIGHTS RESERVED.

LOC	DIST	REVISIONS					
GE	00	P	LTR	DESCRIPTION	DATE	DWN	APVD
		-		SEE SHEET 1	-	-	-

APPLIES TO ALL TERMINALS
 NOTE: ALL DIMENSIONS ARE METRIC (MM)

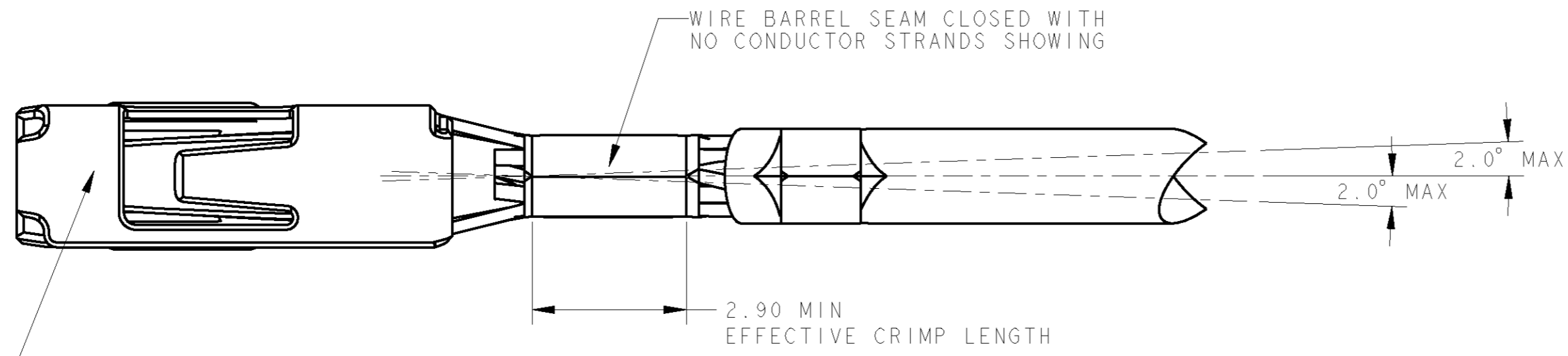

NO DAMAGE OR DISTORTION TO CONTACT

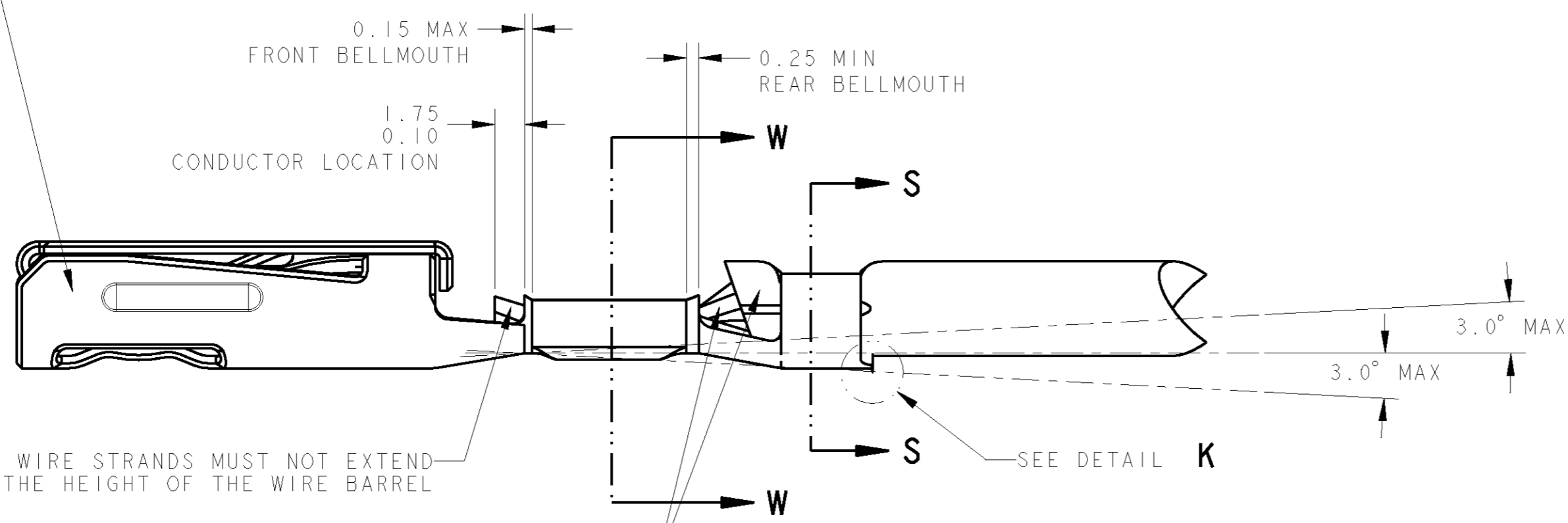

WIRE STRANDS MUST NOT EXTEND BEYOND THE HEIGHT OF THE WIRE BARREL

WIRE CONDUCTORS AND INSULATION MUST BOTH BE VISIBLE IN THIS AREA

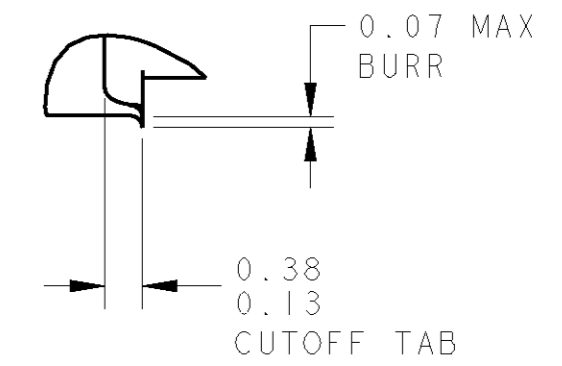

DETAIL K
 SCALE 20:1

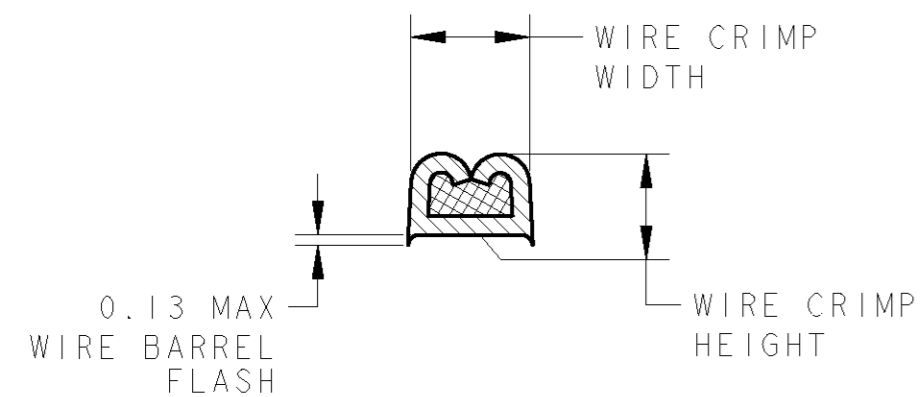

SECTION W-W

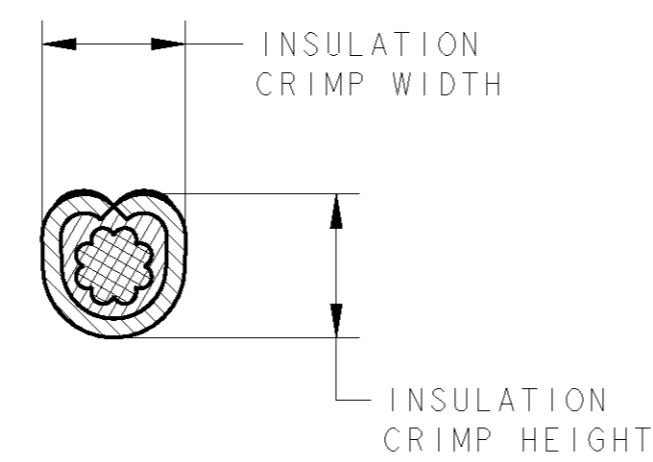

SECTION S-S

WIRE			CONTACT			
SIZE	INSULATION DIAMETER	STRIP LENGTH	WIRE BARREL		INSULATION BARREL	
AWG			CRIMP HEIGHT	CRIMP WIDTH	CRIMP HEIGHT	CRIMP WIDTH
20	1.40-1.95	5.05-6.60	1.03±0.05	1.753-1.803	1.80±0.10	2.03±0.05
18	1.60-2.20		1.13±0.05	1.753-1.803	2.00±0.10	2.03±0.05
16	1.90-2.40		1.36±0.05	2.134-2.184	2.25±0.10	2.54±0.05
14	2.25-2.75		1.61±0.05	2.134-2.184	2.60±0.10	2.54±0.05

ALL TABLE DIMENSIONS ARE METRIC (mm)

THIS DRAWING IS A CONTROLLED DOCUMENT FOR TYCO ELECTRONICS CORPORATION. IT IS SUBJECT TO CHANGE AND THE CONTROLLING ENGINEERING ORGANIZATION SHOULD BE CONTACTED FOR THE LATEST REVISION.

DWN: J. R. SHUEY 28FEB2000
 CHK: J. M. MYER 28FEB2000
 APVD: K. DENLINGER 28FEB2000

Tyco Electronics
 Harrisburg, PA 17105-3608

NAME: CONTACT, FEMALE, 1.5mm, TIN PLATED

SIZE: A2 CAGE CODE: 00779 DRAWING NO: 638652 RESTRICTED TO: -

MATERIAL: - FINISH: - WEIGHT: -

CUSTOMER DRAWING SCALE: 10:1 SHEET: 2 OF 2 REV: C