

PART NUMBER	REV	FIRST USED
680260-1	A	122500-1
680260-2	A	565435-5

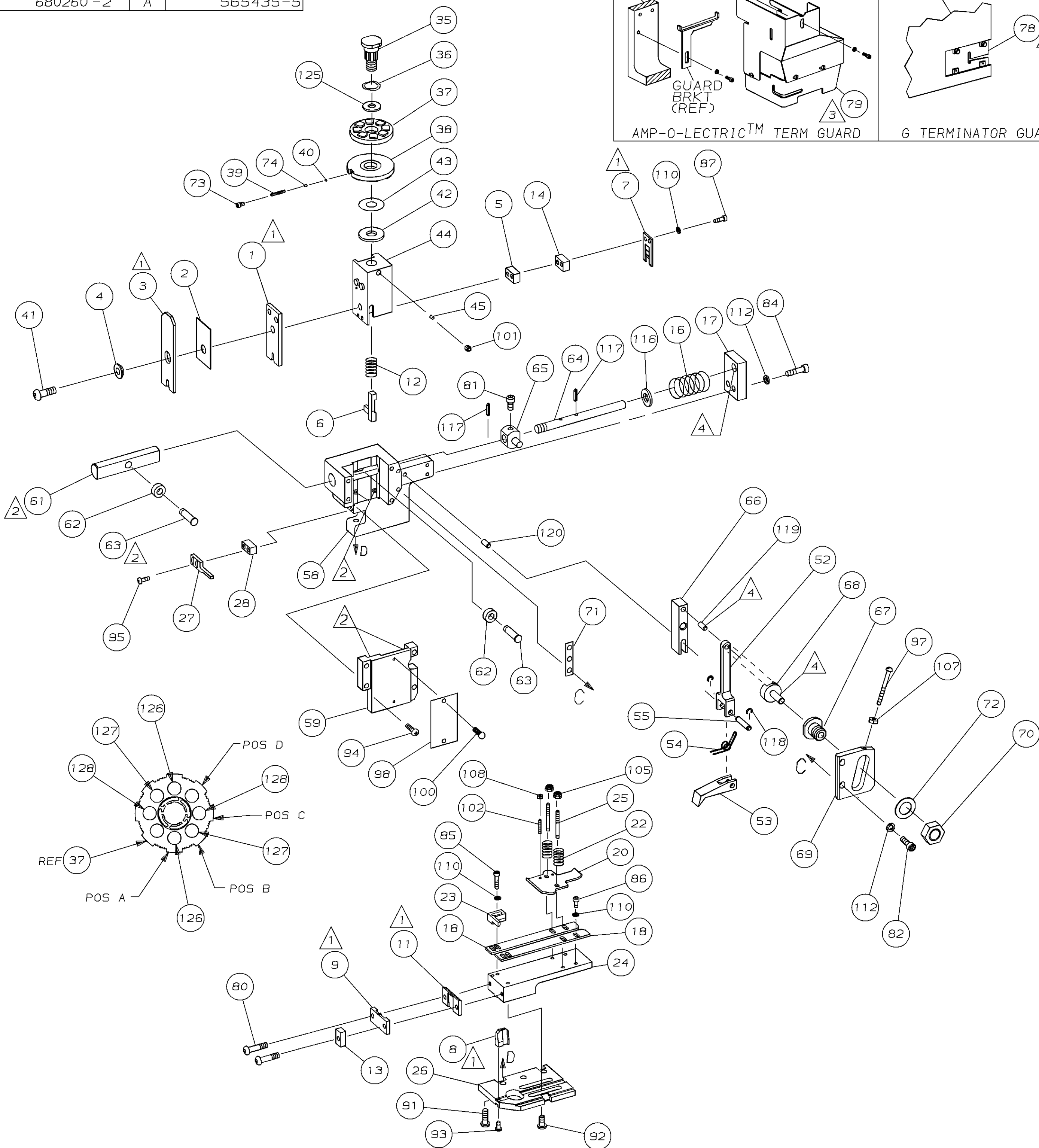

TERMINAL NAME: 5MM POSITIVE LOCK			
141993			
PAD LTR		CRIMPING DATA	
CRIMP	SIZE	TYPE	RANGE
A	.100 ±.002 [2.53 ±0.05mm]		5mm <sup>2</sup>
B	.091 ±.002 [2.31 ±0.05mm]		4mm <sup>2</sup>
C	.082 ±.002 [2.09 ±0.05mm]		3mm <sup>2</sup>
D	NOT		USED
WIRE	.140 [3.56mm]	F	3mm <sup>2</sup> -5mm <sup>2</sup>
INSUL	.210 [5.33mm]	F	3.6mm-4.9mm
WIRE STRIP LENGTH	TERM APPL SPEC	FEED	APPL INSTRUCTION
-	114-15008	.866	408-8039
			SET UP GAGE LAYOUT
			458638-1 L1730

QTY	REF	REV	U/M	DWG SIZE	PART NO	DESCRIPTION	ITEM NO
2					5-354778-7	PIN, WIRE DISC (.2780)C	129
2					3-354778-8	PIN, WIRE DISC (.2685)B	128
2					2-354778-1	PIN, WIRE DISC (.2600)A	126
1					986950-1	WASHER, FLAT PRECISION	125
1					217238-1	DOCUMENTATION PACKAGE	124
1					4088039	EF APPL INST 408-8039	123
							122
							121
REF	REF	-	A		1-21030-7	PIN, DOWEL (Ø.187x1.50) HSG	120
REF	REF	-	A		1-21030-1	PIN, DOWEL (Ø.187x.50) LEVER	119
REF	REF	-	A		21045-3	RING, RET "C" (Ø.187) FD PIN	118
REF	REF	-	A		5-21028-1	PIN, STD SPRING (Ø.12) FD ADJ ROD	117
REF	REF	-	A		21899-4	WASHER, FLAT (Ø5/16) SCR ADJ	116
							115
							114
REF	REF	-	A		21024-5	WASHER, LOCK (NO.10) FD ROD GDE	112
7	7	-	A		21024-4	WASHER, LOCK (NO.8) SHEAR BL	110
							109
2	2	-	A		21018-4	NUT, HEX (4-40) DRAG	108
REF	REF	-	A		21018-5	NUT, HEX (6-32) FD ADJ PL	107
							106
2	2	-	A		21022-2	NUT, HEX SL (8-32) DRAG STUD	105
							104
							103
2	2	-	A		2-21006-6	SCR, SKT SET (4-40x.62) DRAG	102
1	1	-	A		21009-2	SCR, SKT SET (1/4-20x.25 ) RAM	101
2	2	-	A		21017-2	SCR, DRIVE (#2x.19) ID PLATE	100
1	1	-	A		1-21002-7	SCR, BHC (6-32x.38) CAM	99
1	1	-	B		461264-1	PLATE, IDENTIFICATION	98
REF	REF	-	A		6-23715-5	SCR, PAN HD (6-32x1.50) FEED ADJ	97
							96
2	2	-	A		2-21002-2	SCR, BHC (8-32x.50) STRIPPER	95
REF	REF	-	A		2-21002-9	SCR, BHC (10-32x.75) HSG CAP	94
1	1	-	A		22733-8	SCR, BHC (8-32x.38 LW) ANVIL	93
4	4	-	A		3-21002-3	SCR, BHC (1/4-20x.50) ST 6D PL	92
REF	REF	-	A		2-22733-8	SCR, BHC (1/4-20x.62) BASE PL	91
							90
							89
							88
2	2	-	A		2-21000-7	SCR, SHC (8-32x.50) SLUG BLADE	87
3	3	-	A		2-21000-5	SCR, SHC (8-32x.25) STRIP GUIDE	86
2	2	-	A		2-21000-8	SCR, SHC (8-32x.62) R STRIP GUIDE	85
REF	REF	-	A		3-21000-7	SCR, SHC (10-32x.75) FEED ROD GDE	84
							83
REF	REF	-	A		3-21000-6	SCR, SHC (10-32x.62) FEED ADJ PL	82
REF	REF	-	A		3-21000-4	SCR, SHC (10-32x.38) PIVOT BLOCK	81
2	2	-	A		3-21002-0	SCR, BHC (10-32x.88) SHEAR PL	80
REF	-	-	A		455745-1	GUARD, WINDOW	79
-	REF	-	A		679532-1	INSERT, GUARD	78
							77
							76
							75
1	1	-	A		690603-1	SPRING, ASSIST	74
1	1	-	A		23030-1	SCR, SKT CAP (6-32x.25) CP DSC	73
REF	REF	-	A		458109-1	WASHER, FLAT (SPECIAL)	72
REF	REF	-	A		690517-1	SPACER	71
							70
							69
							68
							67
							66
							65
							64
							63
							62
							61
							60
							59
							58
							57
							56
							55
							54
							53
							52
							51
							50
							49
1	-	-	B		690501-3	CAM, POST FEED 1 1/8 ST	48
-	1	-	B		690501-4	CAM, POST-FEED 1 5/8 ST	47
							46
1	1	-	A		690191-1	PLUG, NYLON	45
1	1	-	C		455674-1	RAM	44
1	1	-	A		690125-1	WASHER, LAMINATED	43
1	1	-	A		690124-9	WASHER, RAM	42
1	1	-	A		7-21002-9	BOLT, CRIMPER (5/16-24x1.00)	41
1	1	-	A		23241-6	BALL, STEEL	40
1	1	-	A		690170-1	SPRING, COMPRESSION	39
1	1	-	C		690142-1	DISC, INSULATION	38
1	1	-	D		354777-1	WIRE DISC, PLASTIC	37
1	1	-	A		22480-5	WASHER, SPRING	36
1	1	-	B		690212-1	POST, RAM	35
							34
							33
							32
1	1	-	D		458980-1	APPLICATOR, BASIC (SUB ASSY)	31
							30
							29
1	1	-	B		3-690451-2	SPACER, STRIPPER	28
1	1	-	A		240639-1	STRIPPER	27
REF	REF	-	C		455676-1	PLATE, BASE	26
2	2	-	A		22354-8	DRAG, STUD	25
1	1	-	B		458803-2	PLATE, STRIP GUIDE	24
1	1	-	C		240825-5	PLATE, STRIP HOLD DOWN	23
2	2	-	A		4-22281-1	SPRING, DRAG	22
							21
1	1	-	A		462925-1	DRAG, STOCK	20
							19
2	2	-	C		454204-3	GUIDE, STRIP (FRONT)	18
REF	REF	-	A		454178-1	GUIDE, FEED ROD	17
REF	REF	-	A		4-22284-9	SPRING, FEED RETURN	16
							15
1	1	-	C		6-240641-7	SPACER, SLUG BLADE	14
1	1	-	C		690481-1	SPACER, HOLD DOWN	13
1	1	-	A		23846-1	SPRING, HOLD DOWN	12
1	1	-	B		240833-2	PLATE, REAR SHEAR	11
							10
1	1	-	B		690496-6	PLATE, FRONT SHEAR	9
1	1	-	D		1-461295-8	ANVIL	8
1	1	-	B		2-690474-4	BLADE, SLUG	7
1	1	-	D		2-455892-0	HOLD DOWN, TERMINAL	6
1	1	-	C		2-240641-9	SPACER, SLUG BLADE	5
1	1	-	B		238009-1	SPACER, BLOCK CRIMPER	4
1	1	-	C		6-683453-8	CRIMPER, INSULATION	3
1	1	-	B		455888-6	SPACER, CRIMPER	2
1	1	-	C		456411-9	CRIMPER, WIRE	1

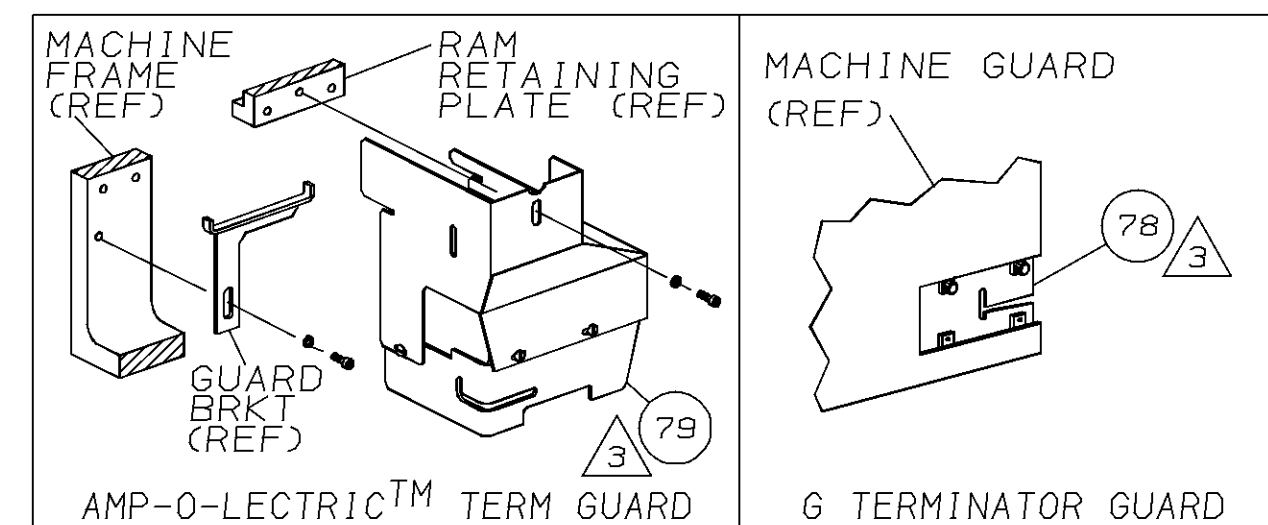
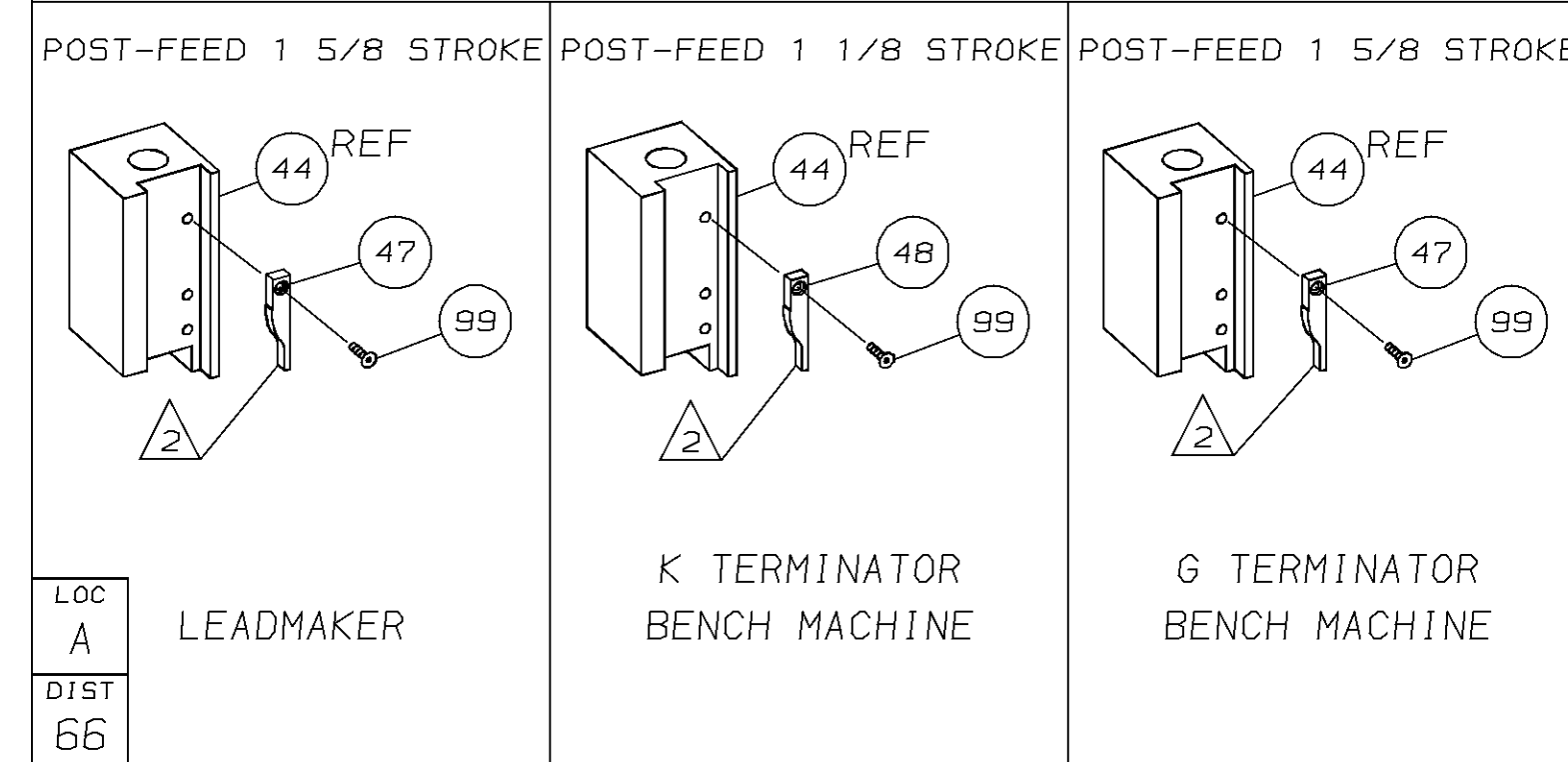

- 1 RECOMMENDED SPARE PARTS.
- 2 GREASE LIGHTLY.
- 3 GUARD MUST BE IN PLACE WHEN OPERATING APPLICATOR IN A BENCH MACHINE.
- 4 LUBRICATE DAILY USING NO. 20 MACHINE OIL.
- 5. ITEMS WITH QTY OF REF SPECIFIED (EXCEPT ITEMS 78 AND 79) ARE USED ON ITEM 32.
- 6 ITEM 78 USED WITH G TERMINATOR ONLY.

LOC A	LEADMAKER	K TERMINATOR BENCH MACHINE	G TERMINATOR BENCH MACHINE
DIST 66			

REV	LEADMAKER & BENCH MODEL	MECH POST FEED	ITEM NO	
-1	BENCH MODEL G	MECH POST FEED		
-2	BENCH MODEL K	MECH POST FEED		
REF	REF	- A	22594-8 NUT, HEX 70	
REF	REF	- B	240628-1 PLATE, ADJ 69	
REF	REF	- B	240626-1 SHAFT, PIVOT 68	
REF	REF	- B	240633-1 BUSHING 67	
REF	REF	- A	455680-1 LEVER, INTERMEDIATE 66	
REF	REF	- B	240629-1 BLOCK, PIVOT 65	
REF	REF	- A	240632-2 SCR, ADJ 64	
REF	REF	- B	240659-3 PIN, CAM ROLLER 63	
REF	REF	- B	240658-1 CAM, ROLLER 62	
REF	REF	- B	454398-1 ROD, FEED 61	
			60	
			59	
			58	
			57	
			56	
			55	
			54	
			53	
			52	
			51	
			50	
			49	
1	-	-	B	690501-3 CAM, POST FEED 1 1/8 ST 48
-	1	-	B	690501-4 CAM, POST-FEED 1 5/8 ST 47
				46
1	1	-	A	690191-1 PLUG, NYLON 45
1	1	-	C	455674-1 RAM 44
1	1	-	A	690125-1 WASHER, LAMINATED 43
1	1	-	A	690124-9 WASHER, RAM 42
1	1	-	A	7-21002-9 BOLT, CRIMPER (5/16-24x1.00) 41
1	1	-	A	23241-6 BALL, STEEL 40
1	1	-	A	690170-1 SPRING, COMPRESSION 39
1	1	-	C	690142-1 DISC, INSULATION 38
1	1	-	D	354777-1 WIRE DISC, PLASTIC 37
1	1	-	A	22480-5 WASHER, SPRING 36
1	1	-	B	690212-1 POST, RAM 35
				34
				33
				32
1	1	-	D	458980-1 APPLICATOR, BASIC (SUB ASSY) 31
				30
				29
1	1	-	B	3-690451-2 SPACER, STRIPPER 28
1	1	-	A	240639-1 STRIPPER 27
REF	REF	-	C	455676-1 PLATE, BASE 26
2	2	-	A	22354-8 DRAG, STUD 25
1	1	-	B	458803-2 PLATE, STRIP GUIDE 24
1	1	-	C	240825-5 PLATE, STRIP HOLD DOWN 23
2	2	-	A	4-22281-1 SPRING, DRAG 22
				21
1	1	-	A	462925-1 DRAG, STOCK 20
				19
2	2	-	C	454204-3 GUIDE, STRIP (FRONT) 18
REF	REF	-	A	454178-1 GUIDE, FEED ROD 17
REF	REF	-	A	4-22284-9 SPRING, FEED RETURN 16
				15
1	1	-	C	6-240641-7 SPACER, SLUG BLADE 14
1	1	-	C	690481-1 SPACER, HOLD DOWN 13
1	1	-	A	23846-1 SPRING, HOLD DOWN 12
1	1	-	B	240833-2 PLATE, REAR SHEAR 11
				10
1	1	-	B	690496-6 PLATE, FRONT SHEAR 9
1	1	-	D	1-461295-8 ANVIL 8
1	1	-	B	2-690474-4 BLADE, SLUG 7
1	1	-	D	2-455892-0 HOLD DOWN, TERMINAL 6
1	1	-	C	2-240641-9 SPACER, SLUG BLADE 5
1	1	-	B	238009-1 SPACER, BLOCK CRIMPER 4
1	1	-	C	6-683453-8 CRIMPER, INSULATION 3
1	1	-	B	455888-6 SPACER, CRIMPER 2
1	1	-	C	456411-9 CRIMPER, WIRE 1

REVISION OF EACH ASSY NO (WHEN BLANK, USE DWG REVISION)

REV	U/M	DWG SIZE	PART NO	DESCRIPTION	ITEM NO
-2	-1	U/M			

QTY REQD PER ASSY PARTS LIST

DIMENSIONS IN INCHES. DO NOT SCALE PRINT. TOLERANCES UNLESS OTHERWISE SPECIFIED.

DR M. O'BRINE 2-1-96 APP T. ELBIN 2-1-96  
 CHK 2-1-96 REL 4/15/96  
 C. ERISMAN B. MORGAN

NAME: END FEED HDM APPLICATOR MACHINE REF: MINI APPL  
 SCALE: - DWG NO: 680260 SHEET: 1 OF 1 REV: A

THIS DRAWING IS A CONTROLLED DOCUMENT FOR AMP INCORPORATED. IT IS SUBJECT TO CHANGE AND THE CONTROLLING ENGINEERING ORGANIZATION SHOULD BE CONTACTED FOR THE LATEST REVISION.

THIS INFORMATION IS CONFIDENTIAL AND IS DISCLOSED TO YOU ON CONDITION THAT NO FURTHER DISCLOSURE IS MADE BY YOU TO OTHER THAN AMP PERSONNEL WITHOUT WRITTEN AUTHORIZATION FROM AMP INCORPORATED, HARRISBURG, PA.