

SIZE	Part Num.	Threading	Headscrew
25	8655PHRA2501LF	UNC 4.40	Black
	8655PHRA2502LF	M3	Grey

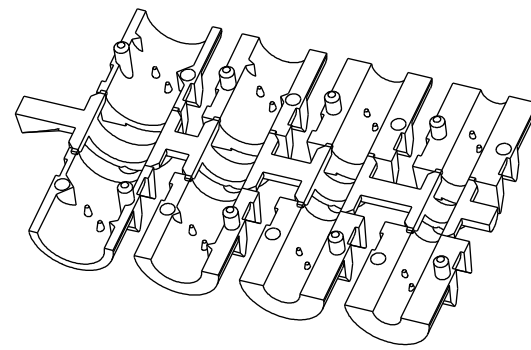

SCALE 1:1

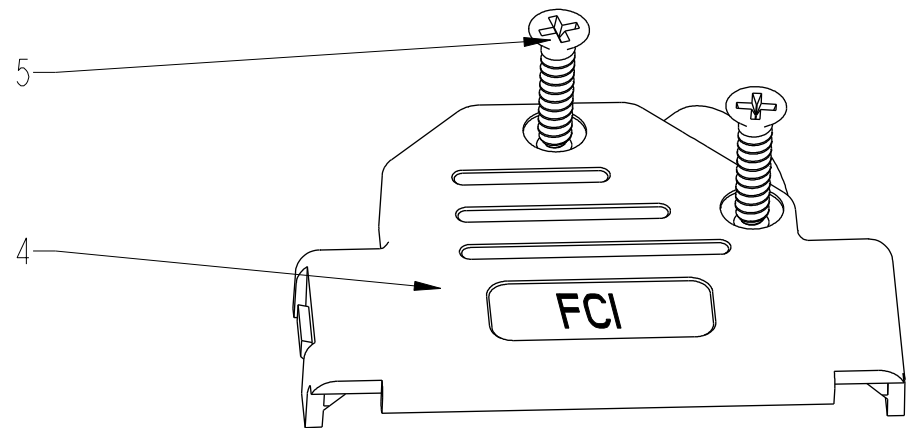
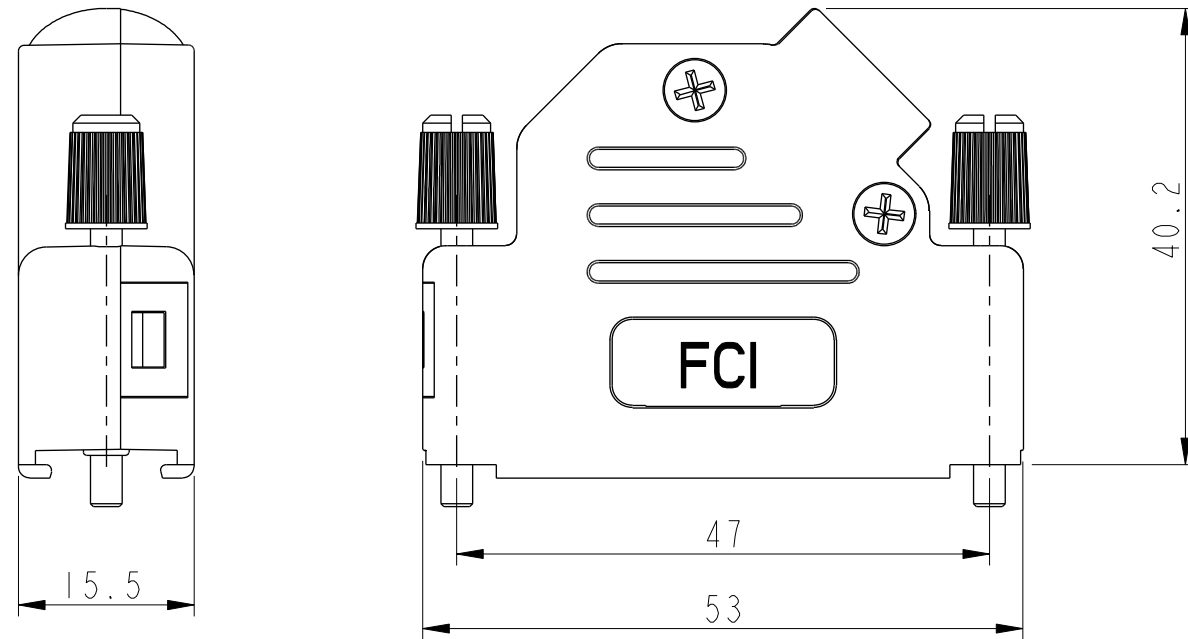
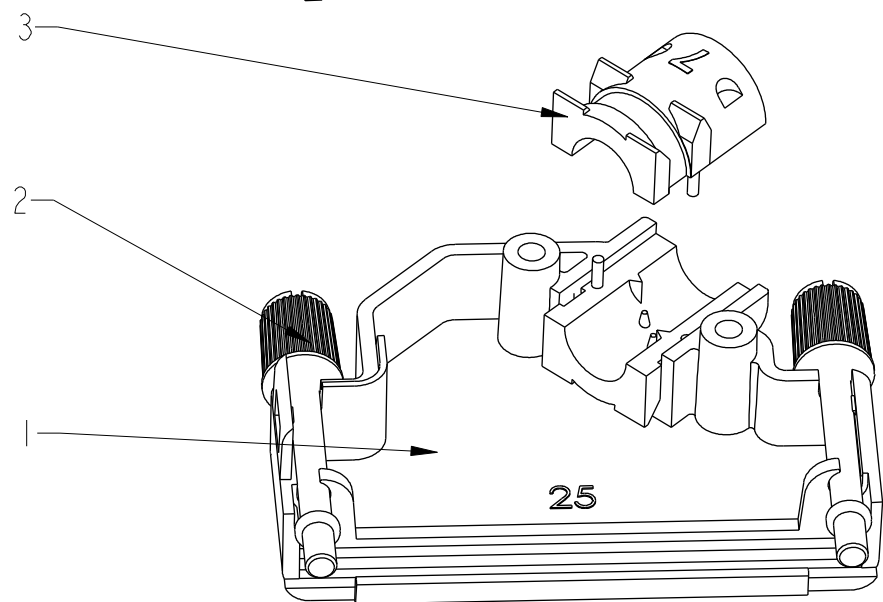

NOTES:

Material: Polycarbonat (UL94V-0)

Cable strain relief: Polycarbonat (UL94V-0)

Temperature range: -40°C to 120°C

Cable diameter: 4,0 to 13,0 mm

Jackscrew:

- Headscrew : plastic, colour according threading
- Body : Metal, threading according tables

Packaging: Bulk, in box of 100 P/N

Covers screwing force (max): 100 Ncm

Jackscrew screwing force (max): 50 Ncm

NOTE:RoHS INFORMATIONS

- The "LF" product meets European union Directives and other country regulations as described in GS-22-008.
- The product is not intended to be exposed to a manufacturing solder process.
- Packaging spec: see GS-14-920.

DESIGNATION	REP	09	15	25	37
COVER BOTTOM	1			1	
JACKSCREWS	2	1		2	
STRAIN RELIEF	3		2		
COVER TOP	4		1		
SCREWS POZIDRIVE	5			2	

spec ref	-	dr	A Parrenin	2011/04/15	projection	mm	size	A3	scale	3:2
tolerance std	ISO 406 ISO 1101	eng	J Dalbard	2015/06/22			ecn no	ELX-B-21206-1	rel level	Released
TOLERANCES UNLESS OTHERWISE SPECIFIED		chr	J Dalbard	2015/06/23						
surface	linear	appr	Aymeric Soudy	2015/06/23			dwg no	10061513C	rev	H
ISO 1302	angular	www.fci.com		cat. no.	-		Product - Customer Drw		sheet 1 of 3	

SIZE	Part Num.	Threading	Headscrew
9	8655PHRA0901LF	UNC 4.40	Black
	8655PHRA0902LF	M3	Grey

SIZE	Part Num.	Threading	Headscrew
15	8655PHRA1501LF	UNC 4.40	Black
	8655PHRA1502LF	M3	Grey

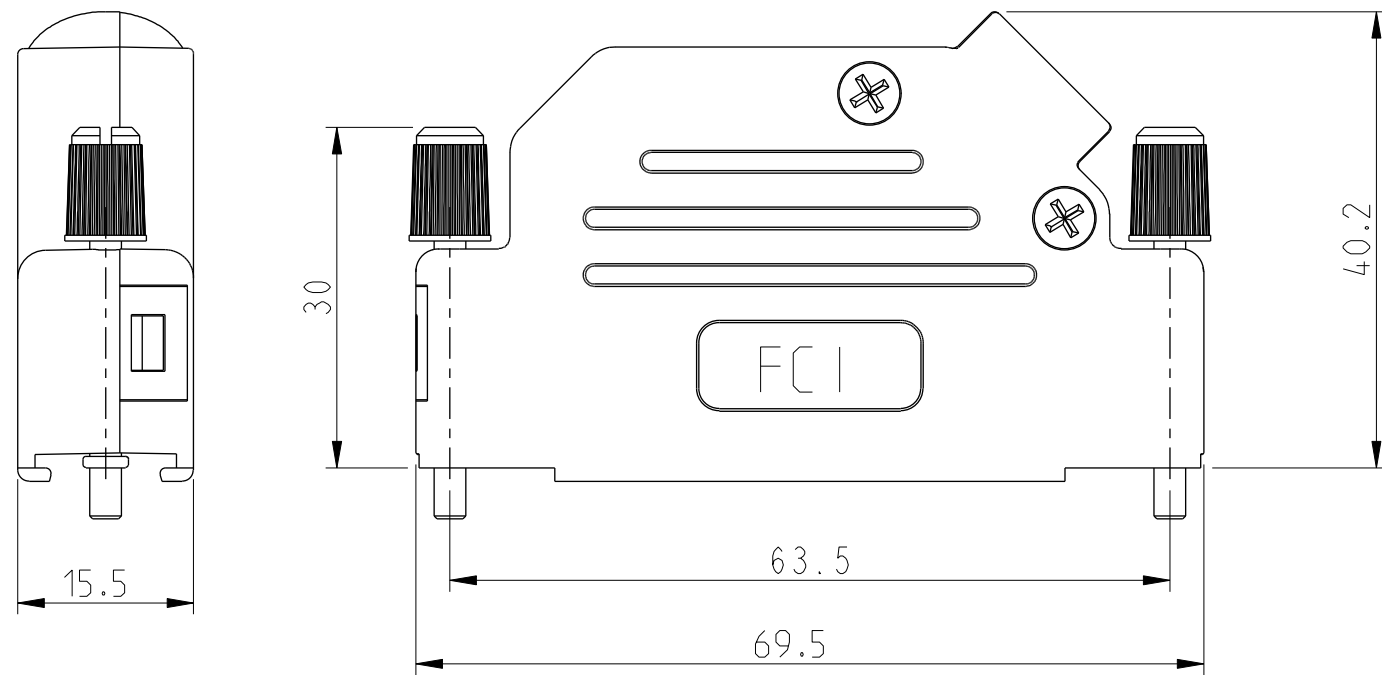
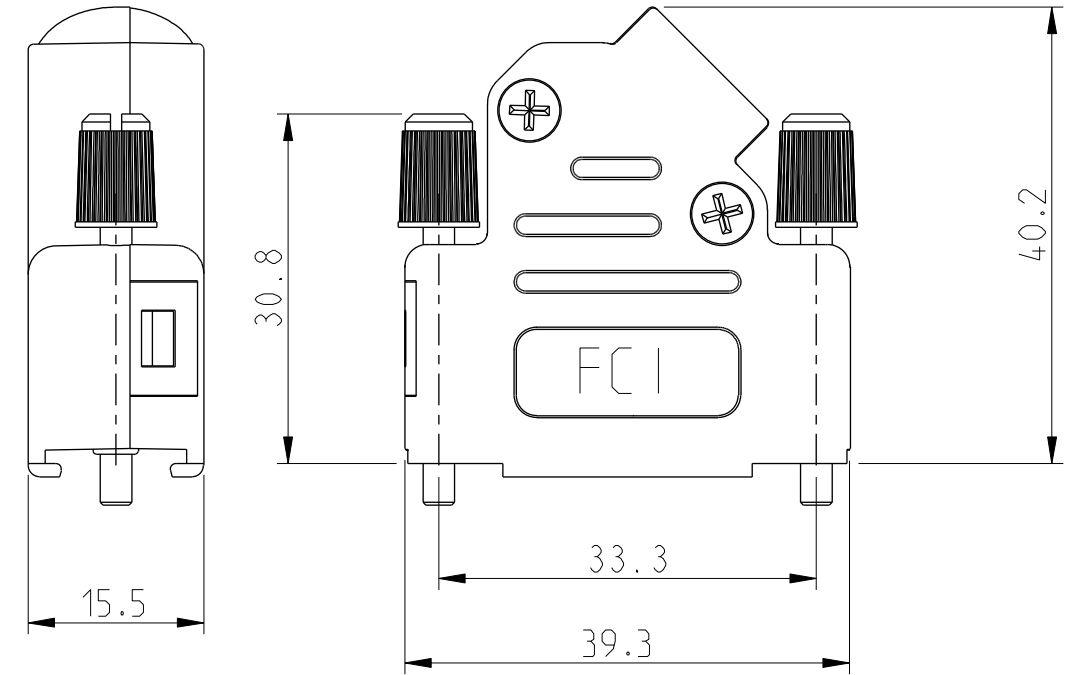
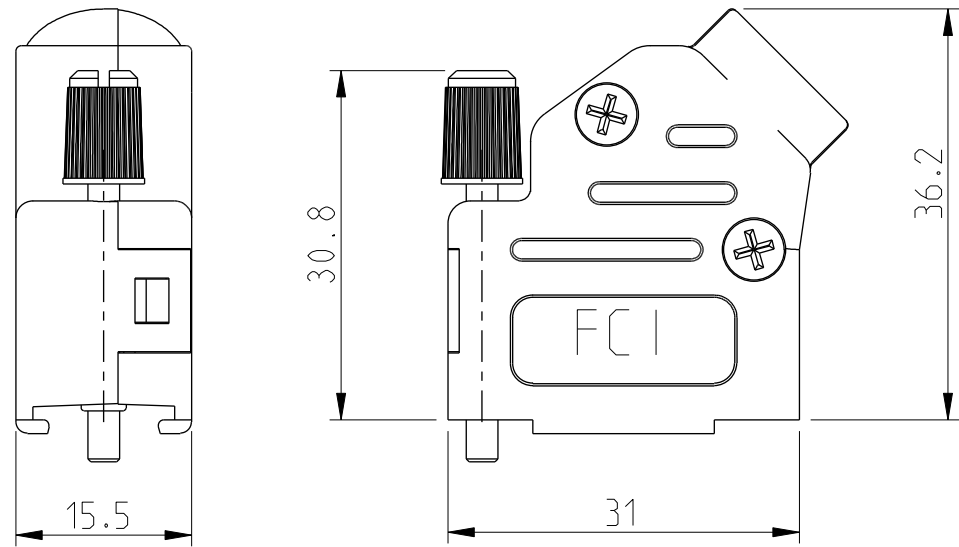

SIZE	Part Num.	Threading	Headscrew
37	8655PHRA3701LF	UNC 4.40	Black
	8655PHRA3702LF	M3	Grey

spec ref	-	dr	A Parrenin	2011/04/15	projection	mm	size	A3	scale	3:2	
tolerance std	ISO 406 ISO 1101	eng	J Dalbard	2015/06/22			ecn no	ELX-B-21206-1			
surface	ISO 1302	chr	J Dalbard	2015/06/23			rel level	Released			
		appr	Aymeric Soudy	2015/06/23	product family		dwg no	10061513C		rev	H
					www.fci.com	cat. no.	Product - Customer Drw		sheet 2 of 3		



Copyright FCI.

CABLING INSTRUCTIONS

1- Use two halves of strain relief different sizes can be mixed (Ø 4, 5, 7 or 9)

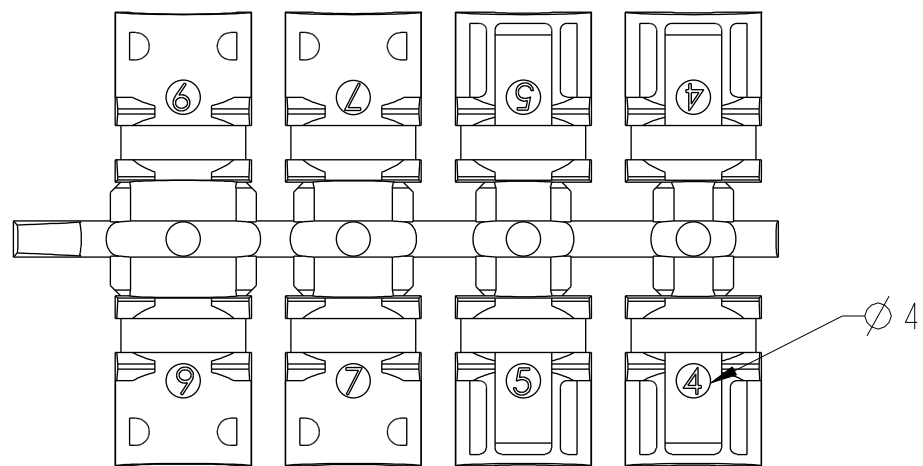

3- Mount connector and cable into the backshell

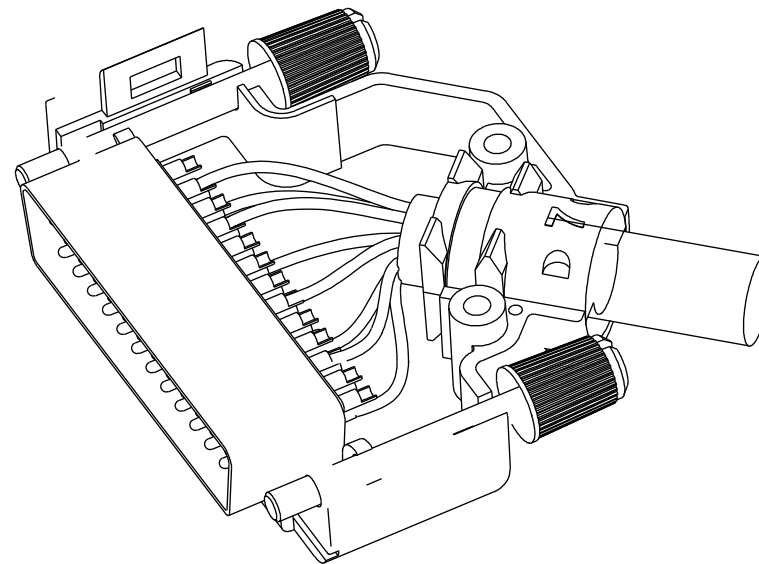

2- Attach the strain relief around the cable

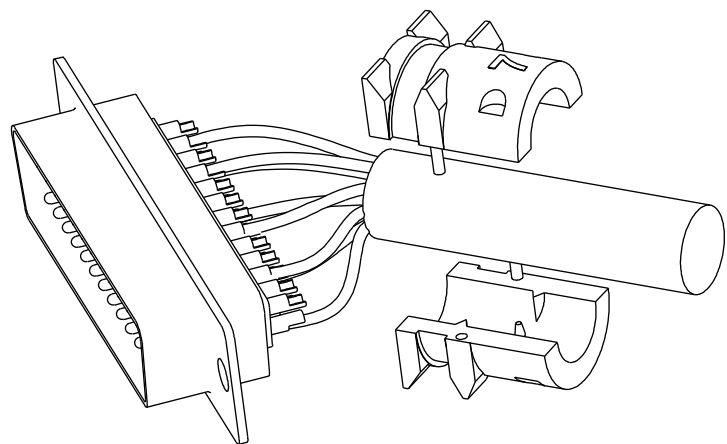

4- Assemble the other half screwing force: 100 Ncm

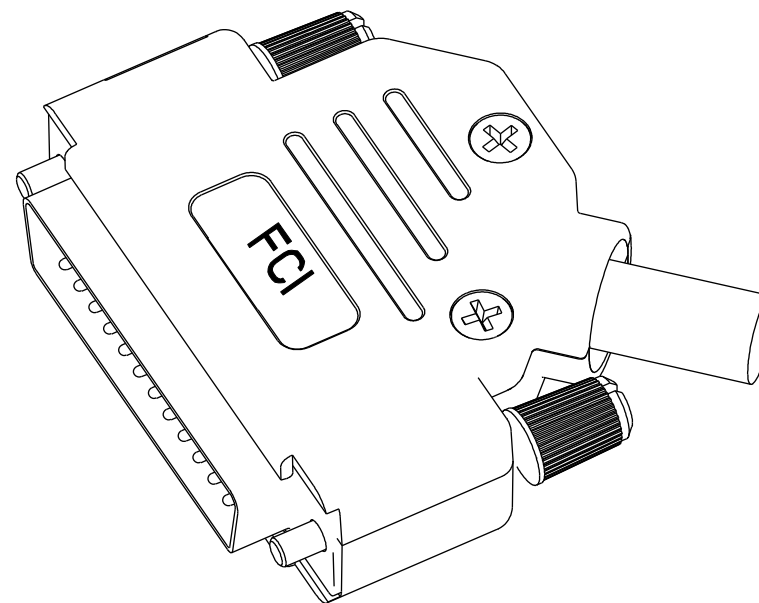

Copyright FCI.

spec ref	-			dr	A Parrenin	2011/04/15	projection	mm	size	A3	scale	3:2
tolerance std	TOLERANCES UNLESS OTHERWISE SPECIFIED			eng	J Dalbard	2015/06/22			ecn no		ELX-B-21206-1	
ISO 406				chr	J Dalbard	2015/06/23			rel level		Released	
ISO 1101				appr	Aymeric Soudy	2015/06/23	product family		rel level		Released	
surface		linear	0.X	±		D-SUB PLASTIC SHELLS ANGLED	cat. no.	Product - Customer Drw	sheet 3 of 3	dwg no 10061513C	rev H	
			0.XX	±								
		0.XXX	±									
ISO 1302		angular	0°	±°	www.fci.com		Product - Customer Drw		sheet 3 of 3			