

LOADING PATTERN MATING SIDE

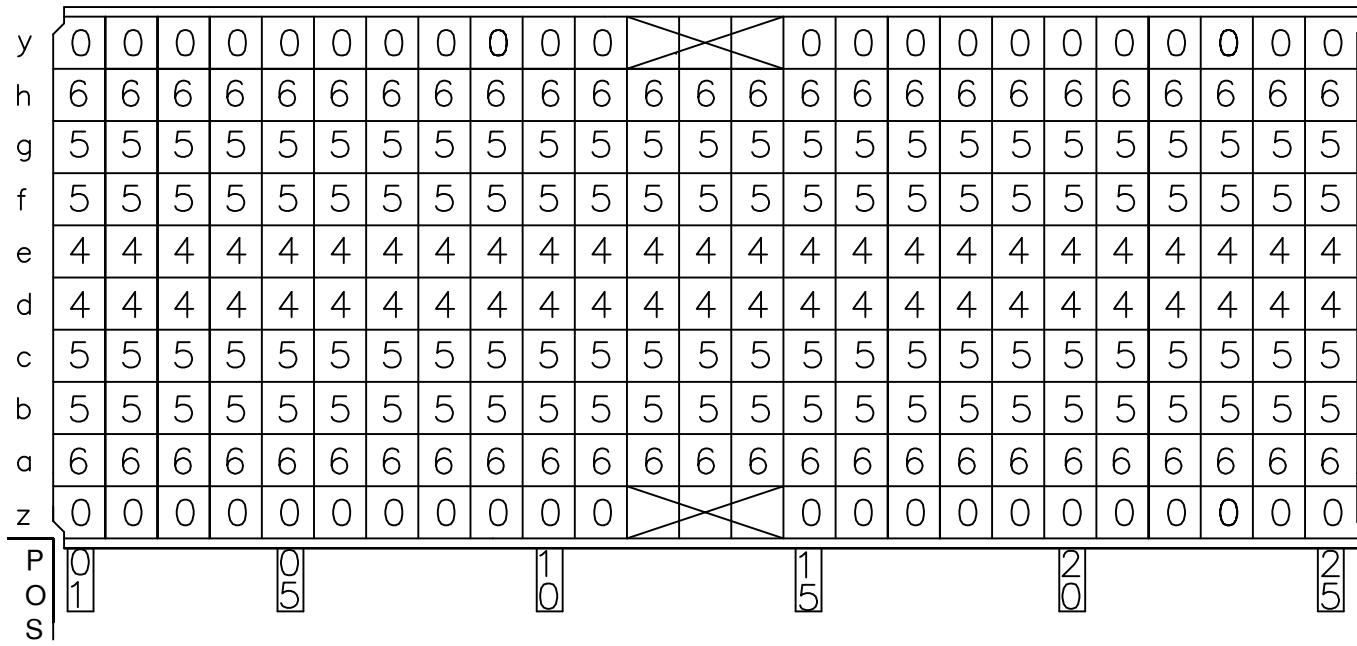

LOADED CONNECTOR ASSEMBLY (FOR EXAMPLE)

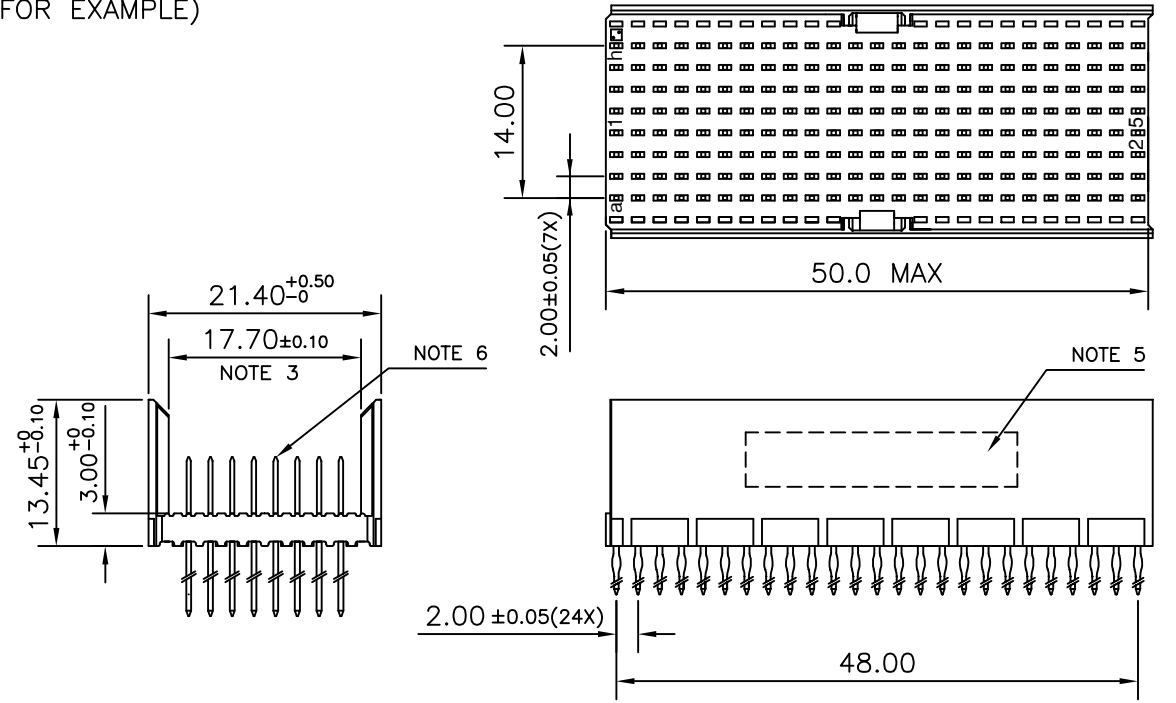

CONTACT OVERVIEW

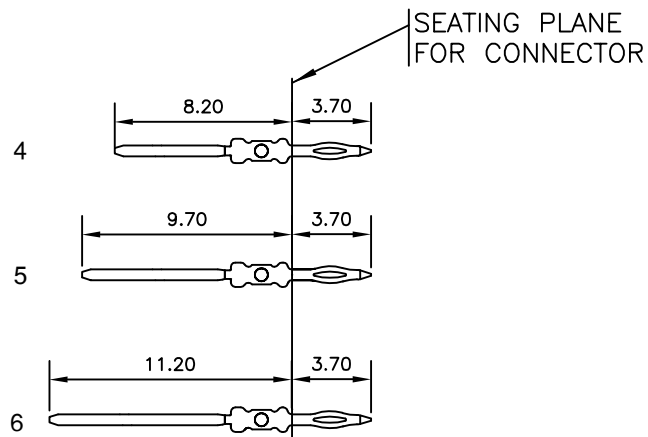

LAY-OUT P.C.B.-HOLE

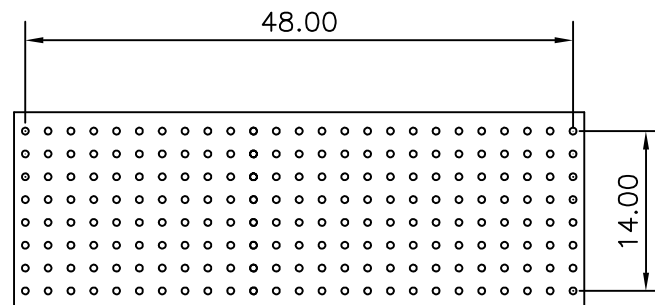

HM2P95PDH910
 LEAD FREE INDICATOR : LF = LEAD FREE (DIGIT 15 & 16)
 PLATING CODE (DIGIT 13 AND 14) (REF DRW NO. BS,C , 201844 , 003)

NOTES

- THIS PRODUCT IS CSA APPROVED.
- THIS PRODUCT IS UL RECOGNIZED.
- MEASURED AT THE BOTTOM.
- MATERIAL CONTACT: PHOSPHORBRONZE
 HOUSING: CREAM WHITE GLASS FILLED POLYESTER UL-94V0
- CONNECTOR PRINTED WITH P/N AND DATE CODE.
- FOR ACTUAL CONTACT LOADINGS, SEE LOADING PATTERN MATING SIDE.
- SHAPE OF CONNECTOR HOUSING CAN ALTER DEPENDING ON PRODUCTION LOCATION
- THE PRODUCT (LF) MEETS EUROPEAN UNION DIRECTIVES AND OTHER COUNTRY REGULATIONS AS DESCRIBED IN GS-22-008
- FOR RECOMMENDED PTH DIMENSIONS REFER DRAWING : BS, A , 201572 , 001
 CATALOG NO: HM2P95PDH910- - -

mat'l. code SEE NOTE 4		surface ISO 1302 ✓	tolerance ISO 406 ISO 1101	projection MM	product family MLLIPACS
ltr	ecn no	dr	date	title MPACS 8+2R STR HDR PF CONN TYPE DE	
A	103-0027	JAY	20/ 06/ 2003	angles linear	scale -
B	105-0171	MINI	23/ 09/ 2005		
C	106-0077	MINI	21/ 06/ 2006	0°±1°	
sheet index		revision sheet	C	type Product Customer Drawing	
		1		sheet 1 of 1 size A3	

FCI
 FCconnect.com
 Copyright FCI