

THIS DRAWING IS UNPUBLISHED. RELEASED FOR PUBLICATION
 © COPYRIGHT BY TYCO ELECTRONICS CORPORATION. ALL RIGHTS RESERVED.

LOC		DIST		REVISIONS			
P	LTR	DESCRIPTION		DATE	DWN	APVD	
B		REVISED PER ECO-05-10413		9/30/05	SS	SRV	

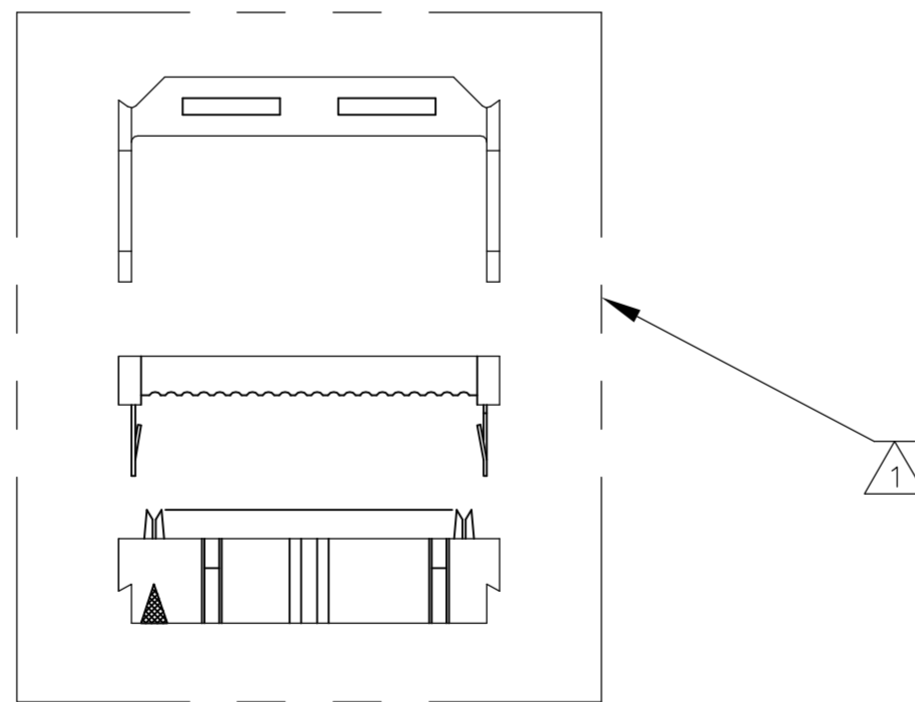
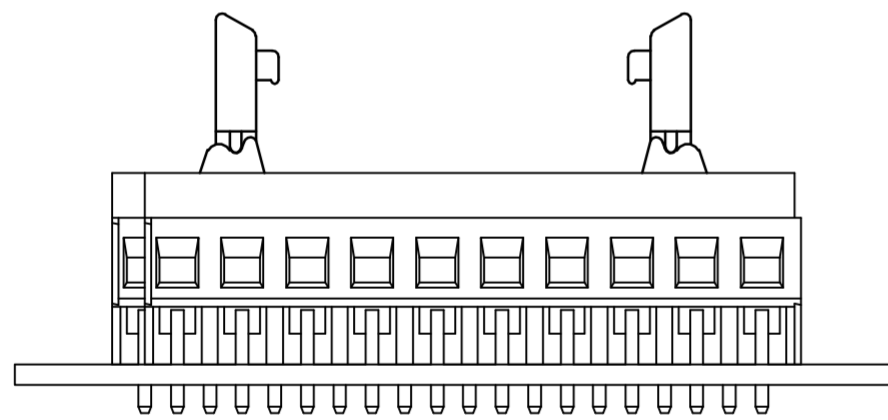
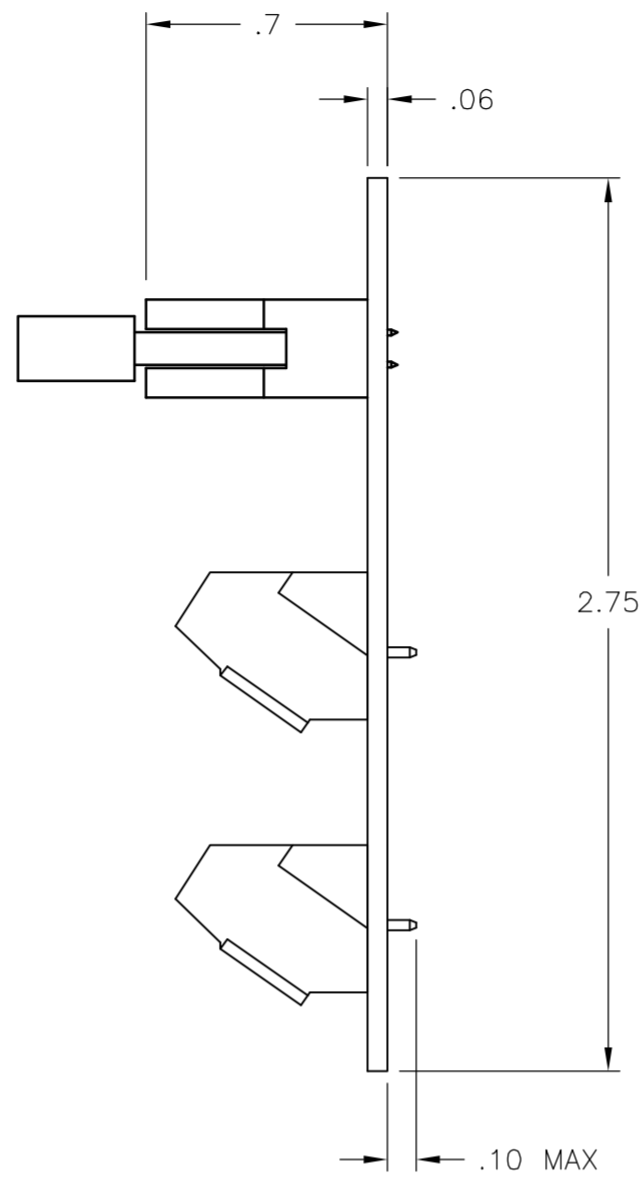
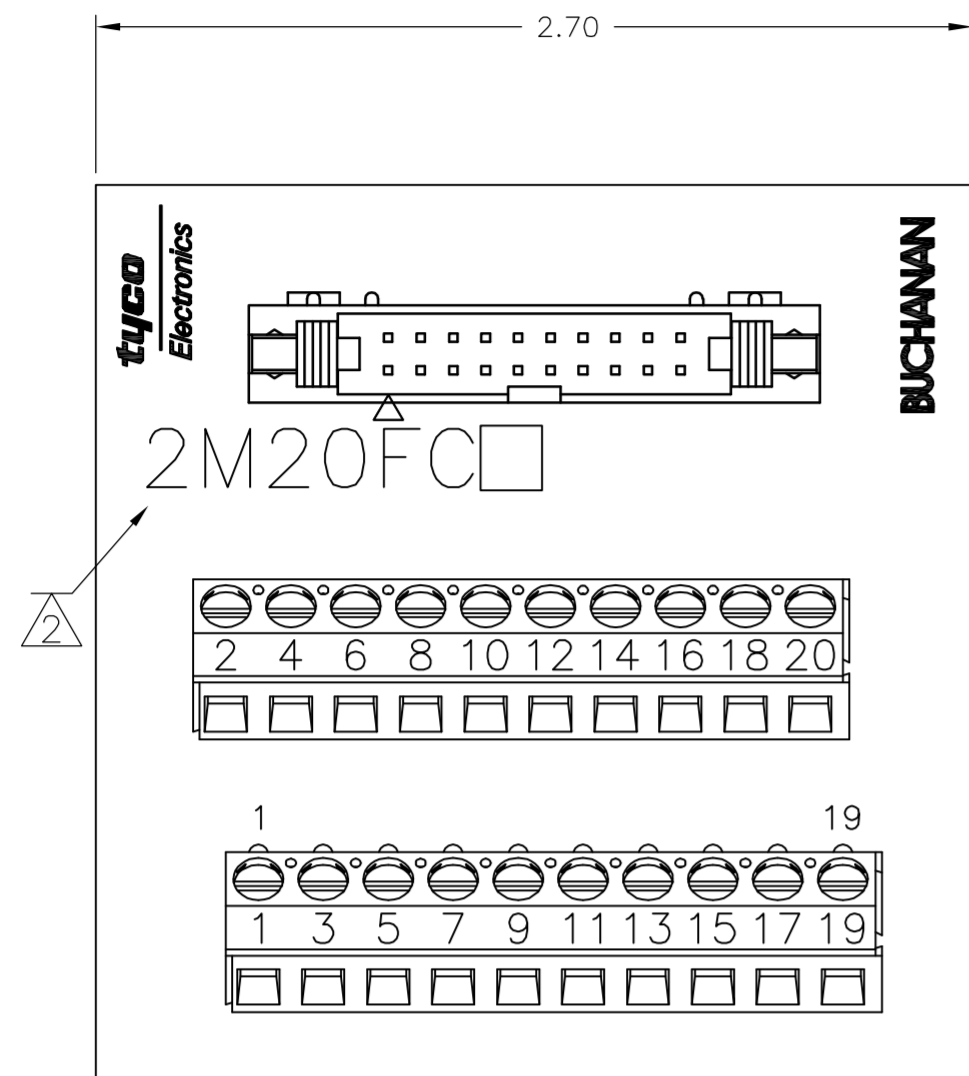

HEADER:
MATERIALS:
 HEADER: COPPER ALLOY, GOLD PLATED, 94V-0 THERMOPLASTIC.
 CONNECTOR: COPPER ALLOY, GOLD OVER NICKEL, 94V-0 THERMOPLASTIC.

ELECTRICAL:
 RATING: 1 AMPERE MAX. (CONNECTOR).

MECHANICAL:
 WIRE RANGE: 26-30 AWG SOLID, 28 AWG STRANDED.

TERMINAL BLOCK:
MATERIALS:
 HOUSING: THERMOPLASTIC NYLON, BLACK, 94V-0.
 TERMINALS: COPPER ALLOY, BRIGHT ACID-TIN OVER COPPER PLATED.
 SCREWS: 3M, BRASS, NICKEL PLATED

ELECTRICAL:
 RATING: 10A, 300V(UL).

MECHANICAL:
 WIRE RANGE: 14-22 AWG.

MOUNTING:
MATERIALS:
 MOUNTING: 2TK2 AND 2TK2D SERIES SNAPTRACK (SOLD SEPARATELY).

- ① ALL CONNECTOR/STRAIN RELIEF COMPONENTS TO BE SHIPPER LOOSE AND UNASSEMBLED.
- ② CATALOG NUMBER MARKED HERE.
- ③ CONTAINS NO TIN-LEAD PLATING.

③	2M20FCL	1776626-1
	2M20FC	1-1437684-2
	CATALOG NO.	PART NUMBER
		Tyco Electronics Corporation Harrisburg, PA 17105-3608
NAME		2M20FC ASSEMBLY
SIZE	CAGE CODE	DRAWING NO
A2	00779	③ 1-1437684-2
CUSTOMER DRAWING		RESTRICTED TO
SCALE	SHEET	REV
NTS	1 of 1	B

DIMENSIONS:		TOLERANCES UNLESS OTHERWISE SPECIFIED:	
INCHES			
0 PLC	± -		
1 PLC	± .1		
2 PLC	± .01		
3 PLC	± -		
4 PLC	± -		
ANGLES	± -		
FINISH			

DWN	M.S. FEHER	01APR2004
CHK	S. YODER	01APR2004
APVD	S. YODER	01APR2004
PRODUCT SPEC		
APPLICATION SPEC		
WEIGHT		