

**STRAIGHT BULKHEAD PLUG CRIMP TYPE  
CABLE 2.6/50 S - PACK. 100**

**R128.083.827**  
**SERIES BMA COM**

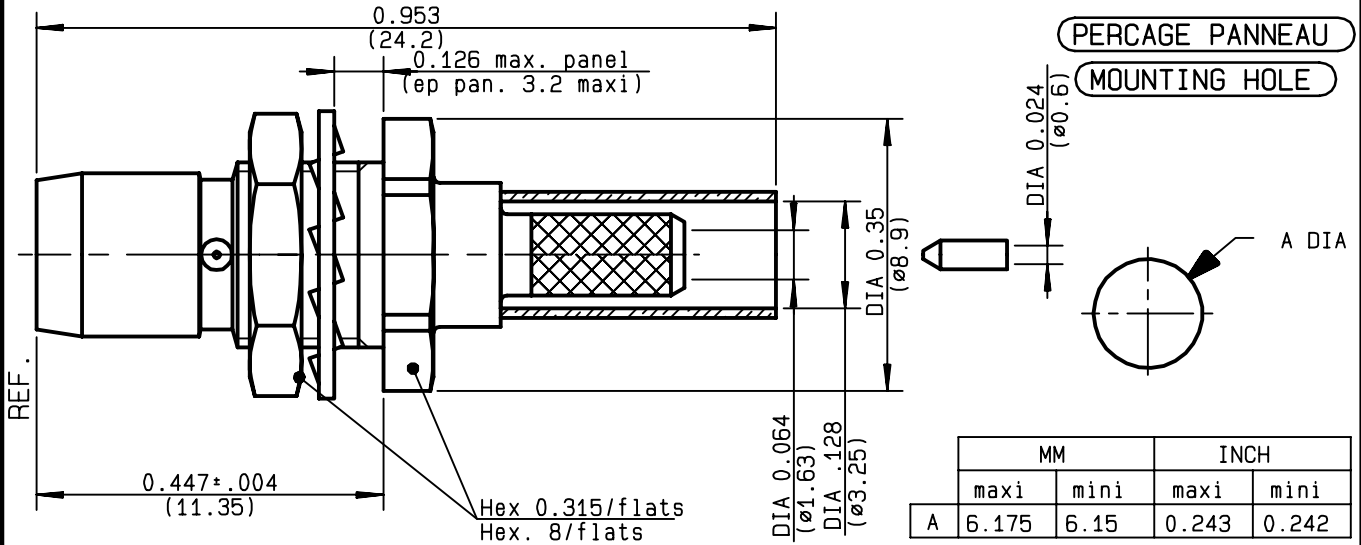

NOMINAL IMPEDANCE	<b>50</b>	$\Omega$
FREQUENCY RANGE	<b>0-12.4</b>	GHz
TEMPERATURE RATING	<b>-65/+125</b>	$^{\circ}\text{C}$
V.S.W.R	<b>1.15</b> +	<b>.02</b> x F(GHz)Maxi
RF INSERTION LOSS	<b>0.03</b>	$\sqrt{F}$ (GHz) dB Maxi
VOLTAGE RATING	<b>350</b>	Veff Maxi
DIELECTRIC WITHSTANDING VOLTAGE	<b>1000</b>	Veff Mini
INSULATION RESISTANCE	<b>5000</b>	M $\Omega$ Mini
HERMETIC SEAL	<b>NA</b>	Atm.cm <sup>3</sup> /s
LEAKAGE (pressurized only)	<b>NA</b>	
MECHANICAL DURABILITY	<b>500</b>	Cycles
WEIGHT	<b>3.09</b>	gr
SPECIFICATION		

CABLES : **KX 22A**  
**RG 188**  
**RG 316**

OTHERS CHARACTERISTICS

CABLE RETENTION	<b>110</b>	N Mini
CENTER CONTACT RETENTION		
Axial force - mating end	<b>18</b>	N Mini
Axial force - opposite end	<b>18</b>	N Mini
Torque	<b>NA</b>	cm.N Mini
RECOMMENDED TORQUES		
Mating	<b>NA</b>	cm.N
Panel nut	<b>150</b>	cm.N
Clamp nut	<b>NA</b>	cm.N

CONNECTOR PARTS	MATERIALS	FINISH	(all values are given in micrometers)
BODY	BRASS	BBR 2	
OUTER CONTACT			
CENTER CONTACT	BRONZE	GOLD 1.3 OVER COPPER 2	
INSULATOR	PTFE	-	
GASKET		-	
OTHERS PIECES	BRASS	BBR 2	

ISSUE	CREATION DATE	FILE PART-NUMBER
<b>9926A01</b>	<b>01/10/1996</b>	<b>EPC96-06</b>



BAFFERT

The information given here is subject to change without notice.  
Design changes may be in order to improve the product .

*Connect to the future*



**R128.083.827**

ISSUE 9926A01 SERIES BMA COM

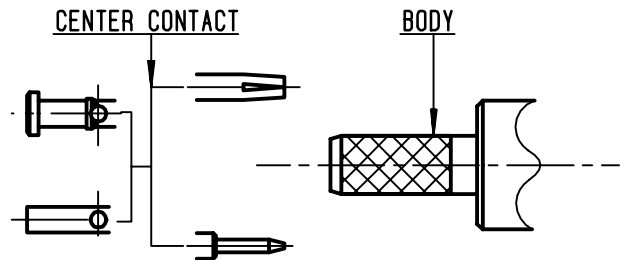
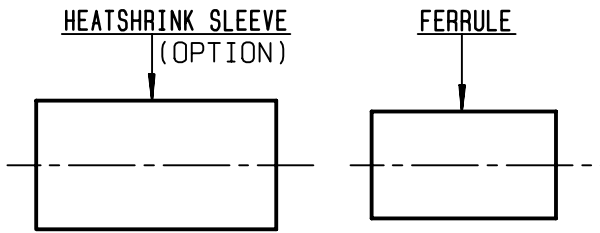

①

Slide ferrule and heatshrink sleeve onto cable .  
(R280.637.020 - Option)  
Strip the cable  
-

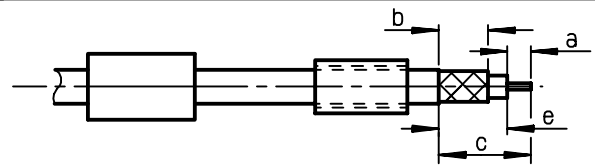

Stripping	a	b	c	d	e
inch	0.059	0.256	0.421	0	0.362
mm	1.5	6.5	10.7		9.2

②

Slide center contact on until it bottoms against cable dielectric .  
Solder center contact .  
Clean soldered area .  
-  
-

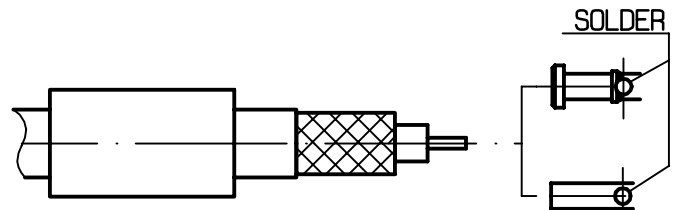

③

Fan the braid .  
Slide cable into body until it bottoms against insulator .  
Slide ferrule over the braid .  
(In direction F)

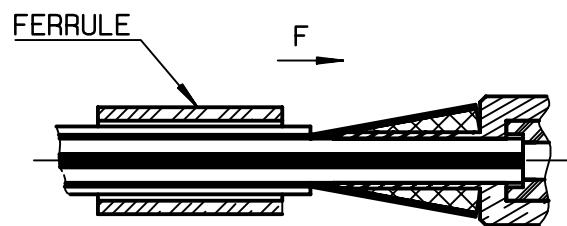

④

Crimp the ferrule with crimping tool R 282 211 000 ( Hex. : 3.25mm) or crimping tool R 282 293 000 ( M22520/5-01) + dies R 282 235 003 ( M22520/5-03 )  
Cut the excess of braid if necessary  
Slide sleeve over ferrule and heatshrink in place (Option).  
-  
-

Shrink the heatshrink sleeve

