

DIGITAL OUTPUT BAROMETER SENSORS

Enhanced Digital Output Sensors: Extended temperature range

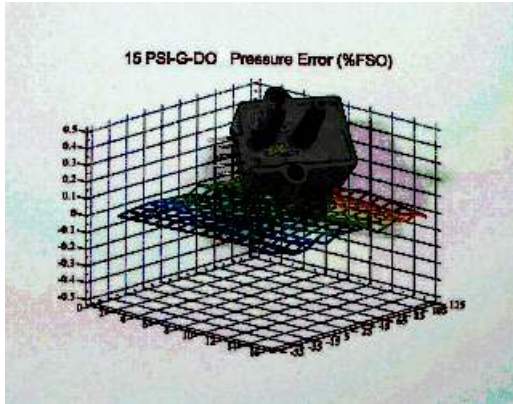

Features

- All Combined Errors Over Temperature Less Than 0.1%, Typical
- Wide -40 to 125°C Compensated Temperature Range
- Electrically Compatible to All Sensors GA142 Series
- Enhanced Dual Serial Interface Mode

Applications

- Medical Instrumentation
- Environmental Controls
- Meteorology

General Description

The Digital Output pressure sensors are based upon a proprietary surface mapping technology to produce a fully digital output that virtually eliminates all repeatable errors over temperature and pressure. This series provides a 12 bit digital serial output (14 bit in High Resolution Mode) with superior offset, span and linearity characteristics. The output is SPI and MICROWIRE/PLUS[®] compatible as well as fully compatible with the All Sensors GA142 Series sensors.

In addition to synchronous communications, the Digital Output pressure sensors incorporates a bi-directional, TTL level, asynchronous serial interfaces mode (hardware selectable 9,600 or 19,200 baud). This mode includes a command set that allows the host to interrogate the sensor for model information, pressure range, serial number, pressure units and conversion factor. The command set also allows the host to select a high resolution output mode, make minor adjustments to offset and has an addressable feature that allows multiple sensors to be tied to the same interface buss.

This series is intended for use with non-corrosive, non-ionic working fluids such as air, dry gases and the like. All signals are 5V TTL/CMOS compatible.

Physical Dimensions

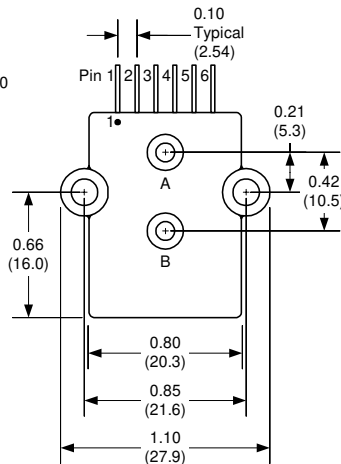
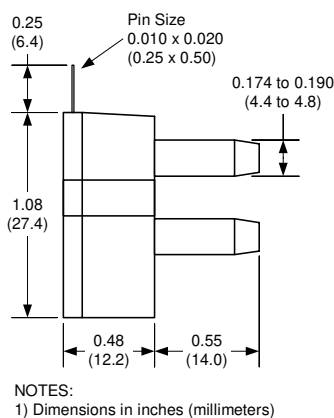

Pressure Applied to Port B

Pin Descriptions

Pin	Label	Description
1	Vcc	+5V power supply input
2	Data/SI	Data output for synchronous mode. Serial in for asynchronous mode.
3	Clock/SO	Clock output for synchronous mode. Serial out for asynchronous mode.
4	Ready/Mode	Ready output for synchronous mode. Selects asynchronous mode when held low during reset.
5	Convert/BR	Convert input for synchronous mode. Selects one of two baud rates for asynchronous mode (low=9,600, high=19,200).
6	Ground	Ground for power and signals



Absolute Maximum Ratings

Supply Voltage (Vcc)	7Vdc
Voltage on Any Pin with Respect to Gnd	-0.6 to Vcc+0.6V
Lead Temperature (soldering 2-4 sec.)	250°C

Environmental Specifications

Operating Voltage	+4.75Vdc to +5.25Vdc
Compensated Temperature	-40°C to +125°C
Operating Temperature	-40 to +125°C
Storage Temperature	-40 to 150°C
Humidity Limits	0 to 95% RH (non condensing)

Standard Pressure Ranges

Part Number	Operating Pressure	Units	Digital Span ⁽⁴⁾	Proof Pressure	Burst Pressure
BARO-DO-MIL	600 to 1100	mBar	3	60 PSI	120 PSI
BARO-INHG-DO-MIL	20 to 32	inchesHg	3	60 PSI	120 PSI
BARO-DO-MIL-PCB	600 to 1100	mBar	3	60 PSI	120 PSI
BARO-INHG-DO-MIL-PCB	20 to 32	inchesHg	3	60 PSI	120 PSI

General Performance Characteristics

Parameter ⁽¹⁾	Minimum	Nominal	Maximum	Units
Resolution	12	--	--	Bit
Conversion Speed	--	8	16	mS
Supply Current	--	8	12	mA
Overall Accuracy ⁽⁵⁾	--	1.0	25	mBar
Long Term Drift (one year)	--	--	20	mBar

Specification Notes

NOTE 1: UNLESS OTHERWISE SPECIFIED, ALL PARAMETERS ARE MEASURED AT 5.0 VOLT SUPPLY, POSITIVE PRESSURE APPLIED TO PORT B.

NOTE 2: THE DIGITAL OUTPUT IS A 16 BIT SIGNED BINARY OUTPUT IN A TWO'S COMPLIMENT FORMAT. THE APPLIED PRESSURE IS COMPUTED USING THE PRESSURE CONVERSION TABLE (BELOW). THE MODE COLUMN IDENTIFIES THE RESOLUTION OPERATING MODE OF THE DEVICE (A = STANDARD RESOLUTION, B = HIGH RESOLUTION). FSO AND UNITS ARE SHOWN FOR EACH MODEL.

NOTE 3: SHIFT IS WITHIN THE FIRST HOUR OF EXCITATION APPLIED TO THE DEVICE.

NOTE 4: DIGITAL SPAN IS DEPENDENT ON THE RESOLUTION OPERATING MODE. REFER TO THE DIGITAL SPAN TABLE (BELOW) TO IDENTIFY THE DIGITAL SPAN OF THE SPECIFIC MODEL. IN THE EVENT OF AN OVER-PRESSURE OR UNDER-PRESSURE CONDITION, THE DIGITAL OUTPUT WILL ONE COUNT HIGHER OR ONE COUNT LOWER (RESPECTIVELY) TO THE LISTED DIGITAL SPAN TO INDICATE THE CONDITION.

NOTE 5: OVERALL ACCURACY INCLUDES THE COMBINED EFFECTS OF OFFSET AND SPAN SHIFTS OVER TEMPERATURE, LINEARITY, HYSTERESIS, AND OFFSET AND SPAN CALIBRATION.

Error Code Table (Asynchronous mode)

Bit 0 : Part not compensated
Bit 1 : Tdex Overflow
Bit 2 : Tdex Over-range
Bit 3 : Pdex Overflow
Bit 4 : Pdex Over-range
Bit 5 : PWL Overflow
Bit 6 : Scaling Overflow
Bit 7 : High resolution overflow
Bit 8 : Pressure Output Limited to Specified Value
Bit 9 through Bit 15 : Reserved

Pressure Conversion Table

Mode	Pressure Output Equation
S	$P_{out} = \text{Digital Output} \times \frac{FSO \times \text{Units}}{10,000}$
H	$P_{out} = \text{Digital Output} \times \frac{FSO \times \text{Units}}{32,767}$

Digital Span Table

Span	Mode S (Standard)	Mode H (High Res)
1	-10,399 to 10,399	-32,767 to 32,766
2	-399 to 10,399	-999 to 32,766
3	5,054 to 10,399	17,501 to 32,766

Option: PCB mounted compatible to GA-series and SMRT series

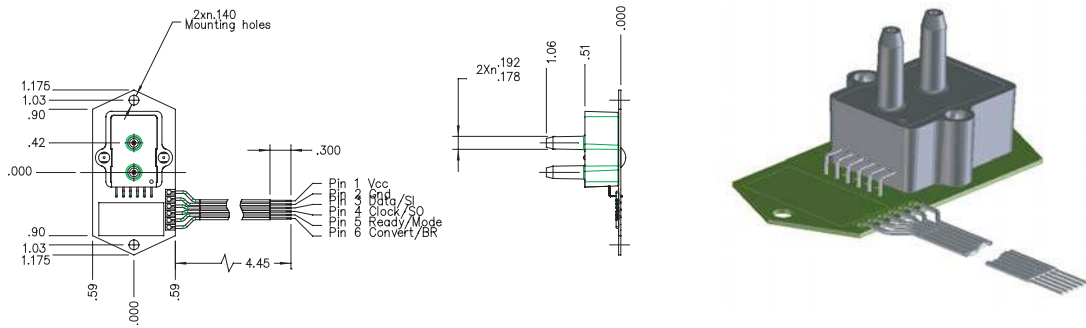

Optional 90 degree lead bend

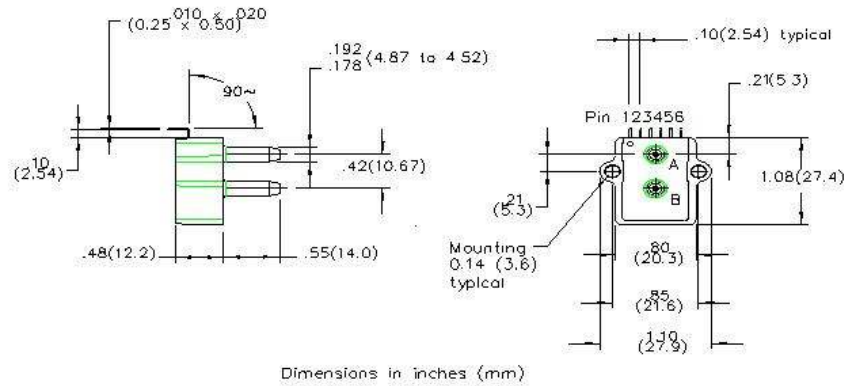

Typical Configurations

Synchronous Communications

Typical synchronous communications configuration (compatible with All Sensors GA142 Series Digital Output Sensors).

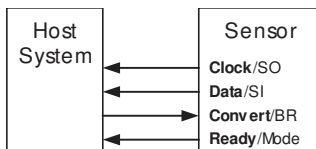

Asynchronous Communications

Typical asynchronous communications configuration. The Mode pin is interrogated at power up and if tied low, will cause the sensor to enter asynchronous communications mode. This mode supports multiple sensors by addressable commands. The Convert/BR pin then serves to select one of two available baud rates.

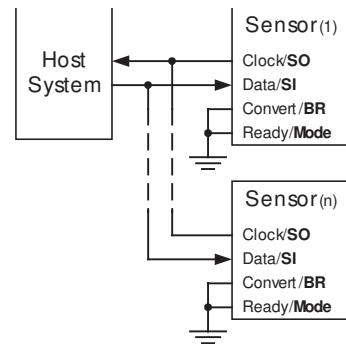

Asynchronous Command Summary ^(1,2)

Command	Description	Response
RD	Read Mode Setting	RD=<Mode>
RM	Read Model Information	RM=<Model String>
RO	Read User Offset Setting	RO=<hhhh>
RP	Read Pressure	RP=<hhhh>
RR	Read Device Pressure Range	RR=<Range String>
RS	Read Serial Number	RS=<Serial Number String>
WD<Mode>	Write Mode Setting ("S" = Standard, "H" = High Resolution)	WD=<Mode>
WO<Offset>	Write User Offset Setting	WO=<hhhh>
U<S/N><Cmd>	Select Unique Part for following command (for multidrop configurations).	U<S/N><Cmd>

Asynchronous Command Notes

- NOTE 1: ALL COMMANDS AND RESPONSES ARE IN ASCII CHARACTER FORMAT AND ARE TERMINATED BY A CARRIAGE RETURN (CARRIAGE RETURNS ARE NOT SHOWN IN COMMAND AND RESPONSE TABLE). EXAMPLE: THE READ HIGH RESOLUTION PRESSURE COMMAND (REPRESENTED BY: RH<CR>) IS GIVEN BY THE FOLLOWING THREE BYTE SEQUENCE: 0x52 0x48 0x0D
- NOTE 2: <hhhh> IS A FOUR BYTE ASCII STRING REPRESENTING A 16-BIT SIGNED VALUE. EXAMPLE: RH=2B7D REPRESENTS THE RESPONSE OF AN RH COMMAND WITH THE PRESSURE OUTPUT OF 0x2B7D (11,133 DECIMAL) VALUE.
- NOTE 3: <LLLL> IS A FOUR BYTE ASCII STRING REPRESENTING THE LOW RESOLUTION OUTPUT (SIMILAR TO THE HIGH RESOLUTION RESPONSE OF NOTE 2)
- NOTE 4: <eeee> IS A 16-BIT ERROR CODE. THE REPRESENTATION IS FOUR BYTE ASCII STRING (EXPRESSING A DOUBLE-BYTE OR 16-BITS). A "NO ERROR" CONDITION IS EXPRESSED AS "0000" WHERE AN ERROR IS EXPRESSED BY SETTING AN INDIVIDUAL BIT OF THE ERROR WORD AND PRESENTING IT IN ASCII HEX FORMAT.
- NOTE 5: {NULL} IS A NULL RESPONSE (NO RESPONSE). THE INTENT UTILITY OF THE COMMAND IS TO APPLY THIS COMMAND IN A MULTIDROP CONFIGURATION (BUSSED CONFIGURATION) AND SIMULTANEOUSLY CAPTURE THE PRESSURE OF ALL OF THE DEVICES ON THE BUSS. THE CAPTURED READINGS CAN SUBSEQUENTLY BE READ USING THE U COMMAND (SELECT UNIQUE PART) IN CONJUNCTION WITH THE RC COMMAND. EXAMPLE: U<S/N>RC<CR>

All Sensors reserves the right to make changes to any products herein. All Sensors does not assume any liability arising out of the application or use of any product or circuit described herein, neither does it convey any license under its patent rights nor the rights of others.

© MICROWIRE/PLUS IS A REGISTERED TRADEMARK OF NATIONAL SEMICONDUCTOR.