

PI3DBS16415

3.3V, 1-20Gbps 2-Lane 2:1 Mux/De-Mux Switch

Features

- 4 Differential Channel, 2:1 Mux/DeMux
- Up to 20 Gbps for applications including USB3.0, USB3.1, 10GE, Thunderbolt 3, and SAS3.0
- Bi-directional operation
- 3dB bandwidth: 14 GHz
- Low Bit-to-Bit Skew, 1ps typ
- Low channel-to-channel skew, 7ps typ
- Low insertion loss: -1.3dB@5 GHz, -1.3dB@8 GHz, -2dB@10 GHz
- Return loss: -21dB@5 GHz, -13dB@8 GHz, -9dB@10 GHz
- Low power consumption - 300µA typ
- Supply Voltage 3.3V
- Industrial Temperature Range: -40°C to 85°C
- Totally Lead-Free & Fully RoHS Compliant (Notes 1 & 2)
- Halogen and Antimony Free. "Green" Device (Note 3)
- Packaging (Pb-free & Green):
 - 42-contact, TQFN (ZH42), 3.5x9mm
 - 40-contact, TQFN (ZLC40), 3x6mm

Block Diagram

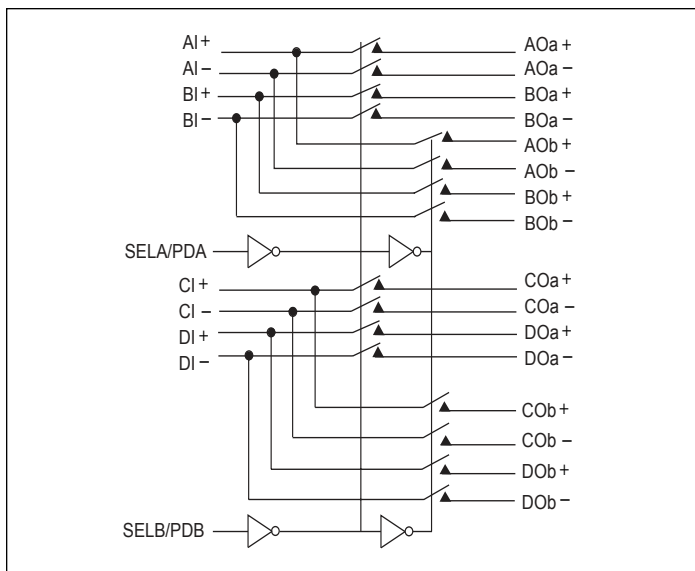

Description

The PI3DBS16415 is an 8 to 4 differential channel multiplexer/de-multiplexer switch. This solution can switch multiple signal types up to data rate of 20Gbps. Using a unique design technique, Diodes has been able to minimize the impedance of the switch such that the attenuation observed through the switch is minimal. The unique design technique also offers a layout targeted for USB3.0, USB3.1, 10GE, Thunderbolt 3, and SAS3.0 signals, which minimizes the channel to channel skew as well as channel to channel crosstalk as required by high speed signals.

Applications

- Routing high speed differential signals such as USB3.1 Gen 2, SAS3, PCIe4, TB3

Ordering Information

Part Number	Package	Description
PI3DBS16415ZH	ZH	42-Contact, Very Thin Quad Flat No-Lead (TQFN)
PI3DBS16415ZL	ZLC	40-Pin, 3x6mm (TQFN)

Notes:

1. No purposely added lead. Fully EU Directive 2002/95/EC (RoHS), 2011/65/EU (RoHS 2) & 2015/863/EU (RoHS 3) compliant.
2. See <https://www.diodes.com/quality/lead-free/> for more information about Diodes Incorporated's definitions of Halogen- and Antimony-free, "Green" and Lead-free.
3. Halogen- and Antimony-free "Green" products are defined as those which contain <900ppm bromine, <900ppm chlorine (<1500ppm total Br + Cl) and <1000ppm antimony compounds.
4. E = Pb-free and Green
5. X suffix = Tape/Reel