

## Product Specification for Approval

WE ARE PLEASED IN SUBMITTING OUR SAMPLES WITH SPECIFICATION TO YOU FOR APPROVAL.

CUSTOMER	:		
DESCRIPTION	:	<b>100/1000 BASE-T TRANSFORMER</b>	
MNC P/N	:	<b>G2401DG</b>	
VERSION	:	<b>A0</b>	
CUSTOMER P/N	:		
ISSUED DATE	:	<b>2020/04/27</b>	
PHOTO OF PRODUCT	:		
WEIGHT	:		<b>2.72g</b>
MADE IN	:		<b>CHINA</b>

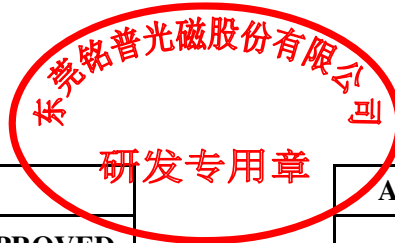

APPROVED BY MNC			APPROVED BY CUSTOMER
PREPARED BY	CHECKED BY	APPROVED BY	SIGNATURE OR STAMP
研发部 2020-04-27 符晶晶	研发部 2020-04-27 肖明华	研发部 2020-04-27 何校民	

1. PLEASE SEND BACK US A COPY OF THE SPECIFICATION WITH YOUR STAMP OR SIGNATURE ONCE THE SAMPLES APPROVED.
2. IT WILL BE DEEMED THE SAMPLES TO BE APPROVED IF NO FEEDBACK.

东莞铭普光磁股份有限公司  
 Add: Shipai Town, Dongguan City, Guangdong Province, China

TEL: +86-769-86921000  
 FAX: +86-769-81701563



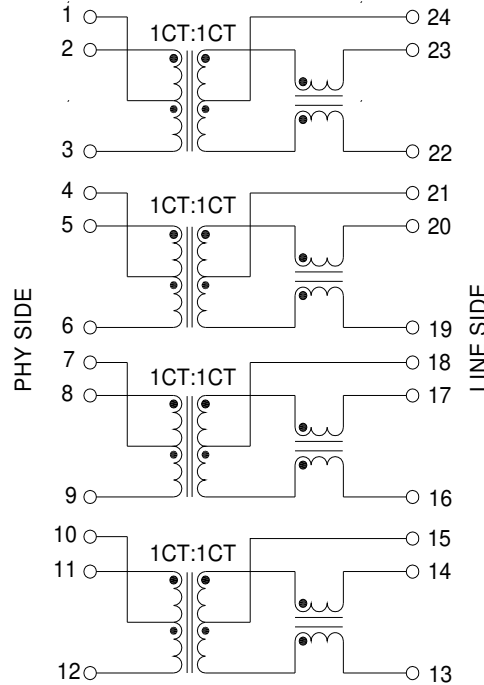

**SPECIFICATION**
**Part No. G2401DG**
**B. SCHEMATIC :**

**C. ELECTRICAL SPECIFICATION @ 25°C**

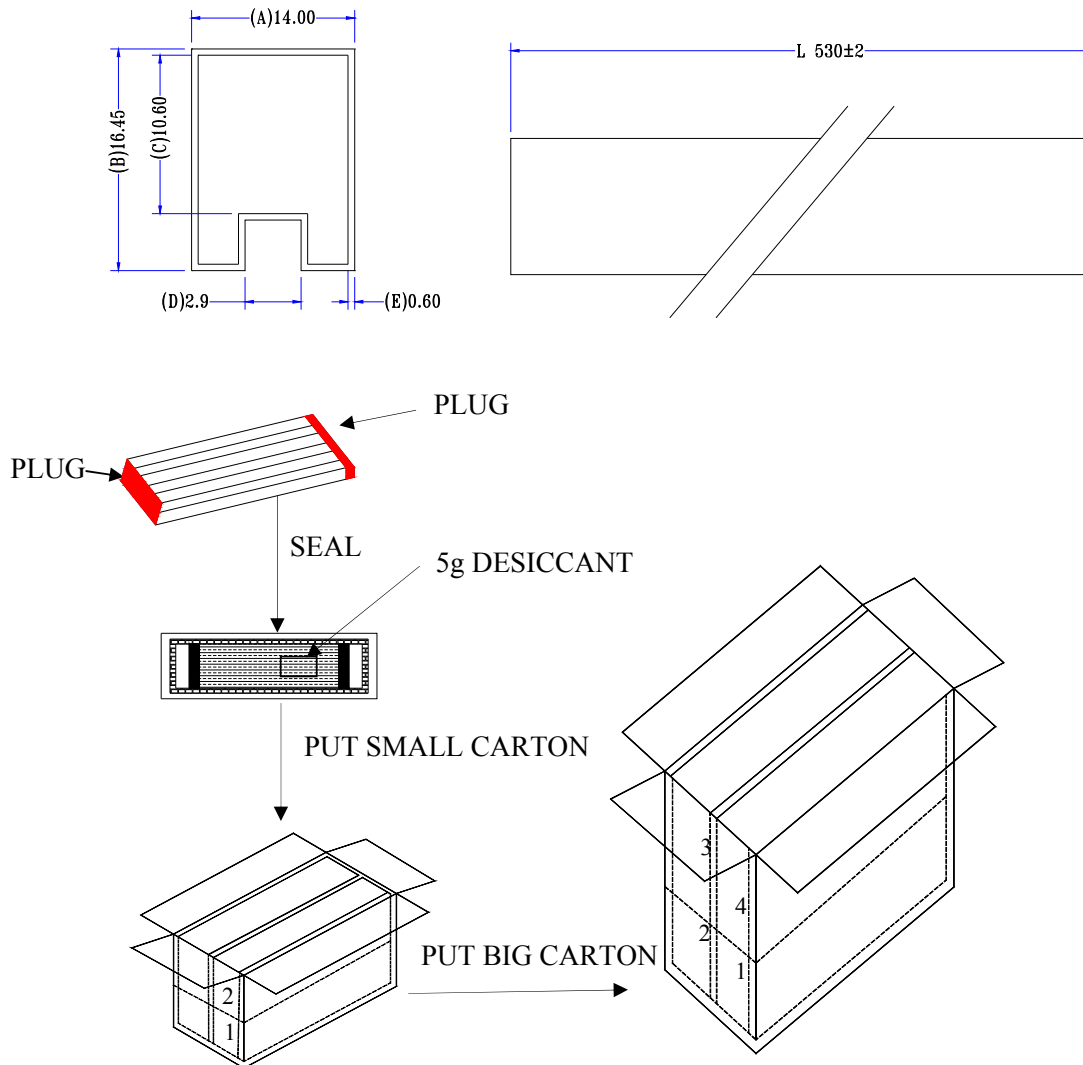
ITEM	SPECIFICATION	TEST CONDITION	TEST EQUIPMENT
INDUCTANCE :	350uH MIN.	100KHz 0.2V 8mA DC Bias	TH2819XB OR EQU.
LEAKAGE INDUCTANCE :	0.50uH MAX.	100KHz 0.2V	TH2819XB OR EQU.
INTERWINDING CAPACITANCE :	25pF TYP.	100KHz 0.2V	TH2819XB OR EQU.
DC RESISTANCE :	1.2Ω MAX.	AT 25 °C	TH2819XB OR EQU.
TURNS RATIO :	1CT:1CT±5%		TH2819XB OR EQU.
POLARITY :	2-23,5-20,8-17,11-14 IN-PHASE		
INSERTION LOSS :	-1.1dB MAX.	0.5-100 MHz	E5061A OR EQU.
RETURN LOSS :	-18dB MIN.	0.5-40 MHz	E5061A OR EQU.
	-12+20log(f/80)dB MIN.	40.1-100 MHz	
CROSS TALK :	-35dB MIN.	0.5-40 MHz	E5061A OR EQU.
	-33+20*log(f/50)dB MIN.	40.1-100 MHz	
CMRR :	-30dB MIN.	0.5-100 MHz	E5061A OR EQU.
HI-POT :PRI TO SEC :	1500VAC	1mA,60S	7152AB OR EQU.
	1650VAC	1mA,6S	
OPERATING TEMPERATURE :	0°C TO 70°C		

**PACKAGE**
**Part No. G2401DG**
**D. PACKING:**
**a. PACKAGING AS BELOW (ONLY FOR A REFERENCE):**

**b. Q'TY:**

32 PCS PER TUBE  
 5 TUBES PER BUNDLE (160 PCS)  
 8 BUNDLES PER BAG (1280 PCS)  
 1 BAG PER SMALL CARTON  
 4 SMALL CARTON PER BIG CARTON(5120PCS)

**c. LABEL:**

**REMARK:**

ABOVE PACKING IS FOR YOUR REFERENCE ONLY, WHICH MIGHT BE CHANGED WITHOUT NOTICE.

**MATERIAL LIST**
**Part No. G2401DG**
**E.BOM**

<b>MATERIAL LIST</b>					
<b>NO.</b>	<b>ITEM</b>	<b>MATERIAL</b>	<b>RATING</b>	<b>SUPPLIER OF MATERIAL</b>	<b>UL</b>
<b>1</b>	<b>CORE</b>	<b>Mn-Zn</b>	-----	<b>YEAN SHING</b>	<b>N/A</b>
			-----	<b>ZHONGSHAN CRC ELECTRONICS FACTORY</b>	<b>N/A</b>
		<b>Ni-Zn</b>	-----	<b>YEAN SHING</b>	<b>N/A</b>
			-----	<b>ZHONGSHAN CRC ELECTRONICS FACTORY</b>	<b>N/A</b>
<b>2</b>	<b>COPPER WIRE</b>	<b>QPN180</b>	<b>180℃</b>	<b>ZHUHAI SUNTEK WIRE CO.,LTD</b>	<b>E234867</b>
		<b>Polysol 180</b>	<b>180℃</b>	<b>ELEKTRISOLA(MALAYSIA) SDN.BHD.</b>	<b>E258243</b>
<b>3</b>	<b>CASE</b>	<b>PF2A5-151J(b)</b>	<b>V-0</b>	<b>CHANGSHU SOUTH-EAST PLASTIC CO.,LTD</b>	<b>E136137</b>
		<b>T378J</b>	<b>V-0</b>	<b>CHANG CHUN CHEMICAL(ZHANGZHOU) CO.,LTD.</b>	<b>E59481</b>
<b>4</b>	<b>PIN</b>	<b>CP WIRE</b>	-----	<b>HIFAM</b>	<b>N/A</b>
<b>5</b>	<b>EPOXY</b>	<b>3300A/B</b>	-----	<b>DONGGUAN EATTO ELECTRONIC MATERIAL CO.,LTD</b>	<b>E218090</b>

**RECOMMENDED SOLDERING PROFILE****Part No. G2401DG****a. RECOMMENDED WAVE SOLDERING PROFILE:****CONDITION:**

- a.1. AVAILABLE FOR ALL THE THROUGH HOLE PARTS
- a.2. SOLDERING METHOD: WAVE SOLDERING
- a.3. SOLDER: Sn-0.7Cu
- a.4. THE RECOMMENDED WAVE SOLDERING CURVE IS AS BELOW

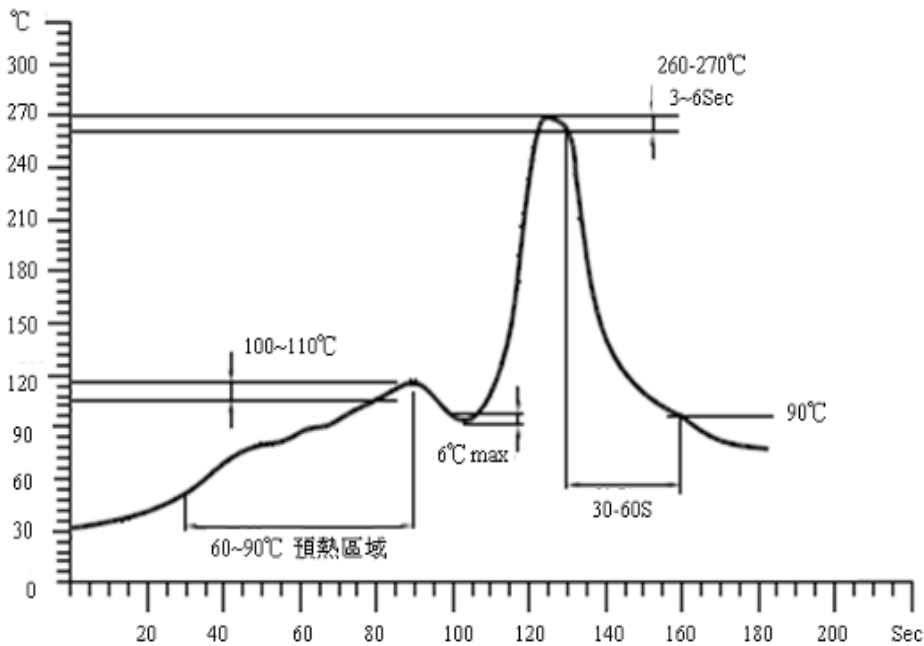
**b. MOISTURE SENSITIVE LEVEL:**

- b.1. LEVEL: 1
- b.2. SHELF LIFE: UNLIMITED
- b.3. STORAGE CONDITION:  $\leq 30^{\circ}\text{C}/85\% \text{RH}$