

Customer Information Sheet

DRAWING No.: K3602-XX

SHEET 2 OF 2

IF IN DOUBT - ASK

©

NOT TO SCALE

THIRD ANGLE PROJECTION

ALL DIMENSIONS IN mm

SEE COMPONENT SPECIFICATION C034XX FOR ASSEMBLY INSTRUCTIONS AND TECHNICAL DATA

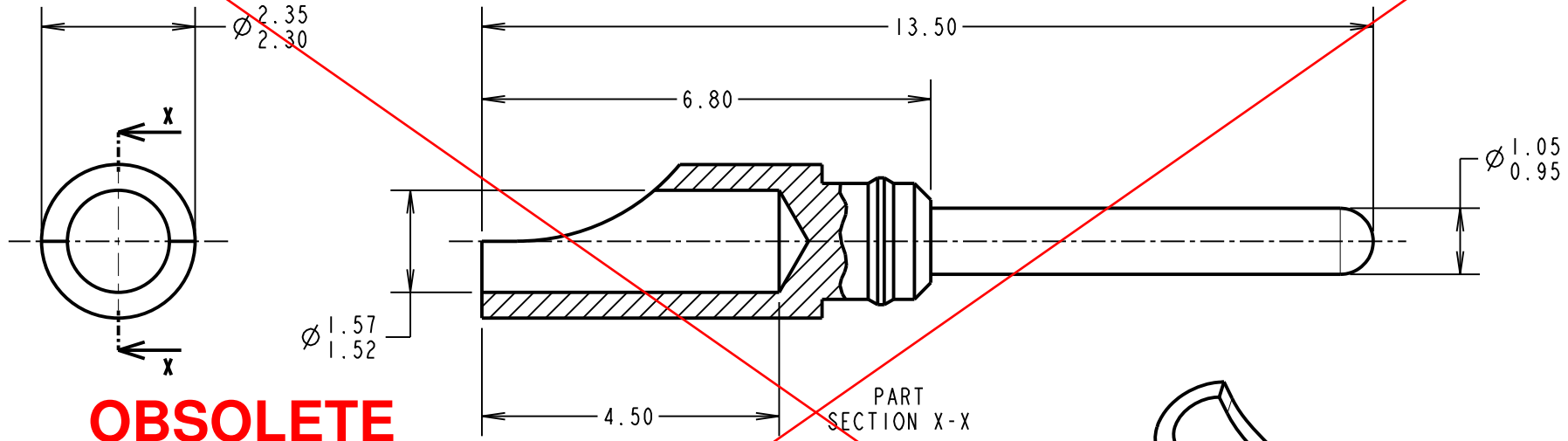

OBSOLETE

- NOTES:
1. RELEVANT SPECIFICATIONS ARE QUOTED ON THE MOULDING DRAWINGS, AND IN COMPONENT SPECIFICATION C034XX (LATEST ISSUE). THE COMPONENT SPECIFICATION ALSO INCLUDES NOTES ON ASSEMBLY METHODS.
 2. THIS SOLDER-BUCKET PIN FITS INTO MOULDINGS K3600-91 (2-WAY POWER CONNECTOR) OR K3700-91 (3-WAY POWER CONNECTOR).
 3. RECOMMENDED WIRE GAUGE = 18AWG, MAXIMUM INSULATION DIAMETER = $\varnothing 1.8\text{mm}$.
 4. STRIP END OF WIRE BY 3.5-4.5mm.
 5. ASSEMBLY TOOL ZK3610-00 CAN USED TO AID INSERTION AND EXTRACTION OF CONTACTS FROM MOULDING.

ORDER CODE:
K3602-XX

FINISH _____
46 = 3.5-5.0 μ 100% TIN OVER NICKEL

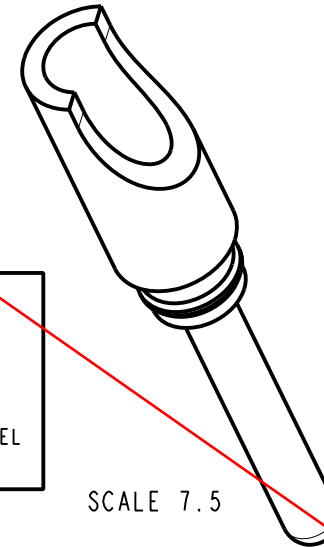

SCALE 7.5

WJP	4	18.03.15	12688
NAME	ISS.	DATE	C/NOTE
APPROVED: WJP			
CHECKED: MGP			
DRAWN: W. J. BOURNE			
CUSTOMER REF.:			
ASSEMBLY DRG:			

HARWIN

www.harwin.com
technical@harwin.com

THIS DRAWING AND ANY INFORMATION OR DESCRIPTIVE MATTER SET OUT HEREON ARE CONFIDENTIAL AND COPYRIGHT PROPERTY OF THE HARWIN GROUP AND MUST NOT BE DISCLOSED, LOANED, COPIED OR USED FOR MANUFACTURING, TENDERING OR FOR ANY OTHER PURPOSE WITHOUT THEIR WRITTEN PERMISSION.

TOLERANCES
X. = $\pm 1\text{mm}$
X.X = $\pm 0.50\text{mm}$
X.XX = $\pm 0.10\text{mm}$
X.XXX = $\pm 0.01\text{mm}$
ANGLES = $\pm 5^\circ$
UNLESS STATED

MATERIAL:
BRASS CW614N - CuZn39Pb3
TO BS EN 12164

FINISH: SEE ORDER CODE

S/AREA: mm²

TITLE:
POWER CONNECTOR
SOLDER-BUCKET PIN

DRAWING NUMBER:
K3602-XX

SHT
2 OF 2