

LOC		DIST		REVISIONS			
P	LTR	DESCRIPTION	DATE	DMN	APVD		
L4		REVISED PER ECO-10-015216	26JUL10	HMR	JO		

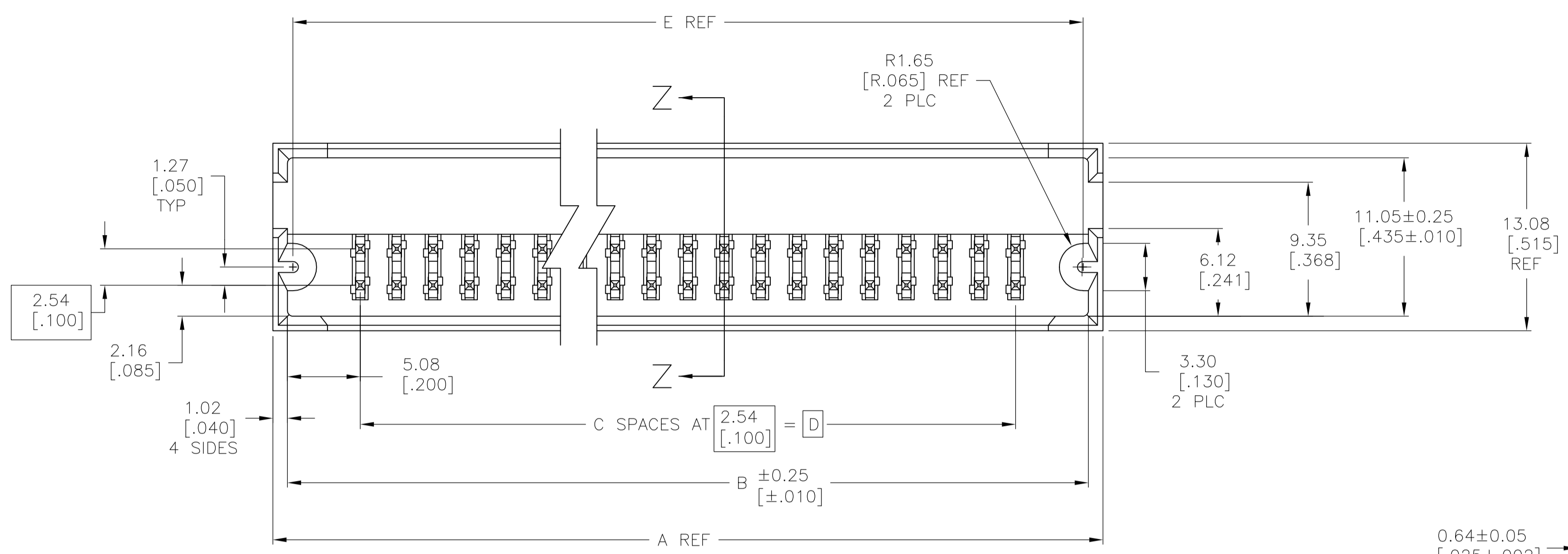

- 1 HOUSING: FLAME RETARDANT THERMOPLASTIC; COLOR: BLACK.
- 2 POST: COPPER ALLOY.
- 3 POST FINISH: 0.00076 [.000030] GOLD IN AREA G, 0.00254-0.00508 [.000100-.000200] BRIGHT TIN-LEAD IN AREA H, ALL OVER 0.00127 [.000050] NICKEL.
- 4 POINT OF MEASUREMENT FOR PLATING THICKNESS.
- 5 RECESSED DATE CODE. CSA LOGO RECESS STAMPED ON HOUSING.
- 6 DUPLEX PLATING: 0.00076 [.000030] GOLD IN AREA G, 0.00254-0.00508 [.000100-.000200] MATTE TIN IN AREA H, ALL OVER 0.00127 [.000050] NICKEL.
- 7 ROHS 2002/95/EC COMPLIANT.
- 8 OBSOLETE PARTS: OBSOLETE CIS STREAMLINING PER D.RENAUD/D.SINISI

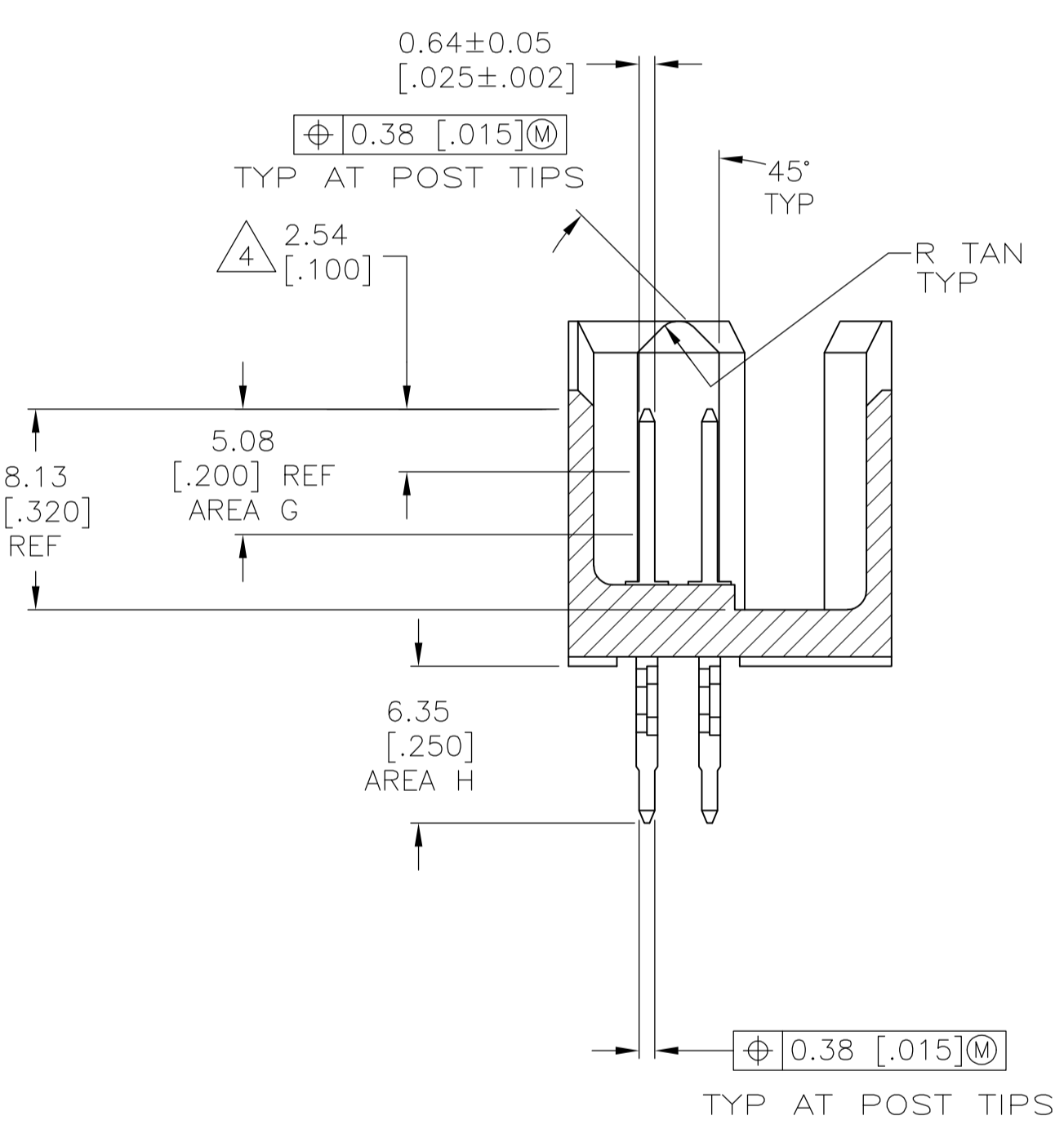
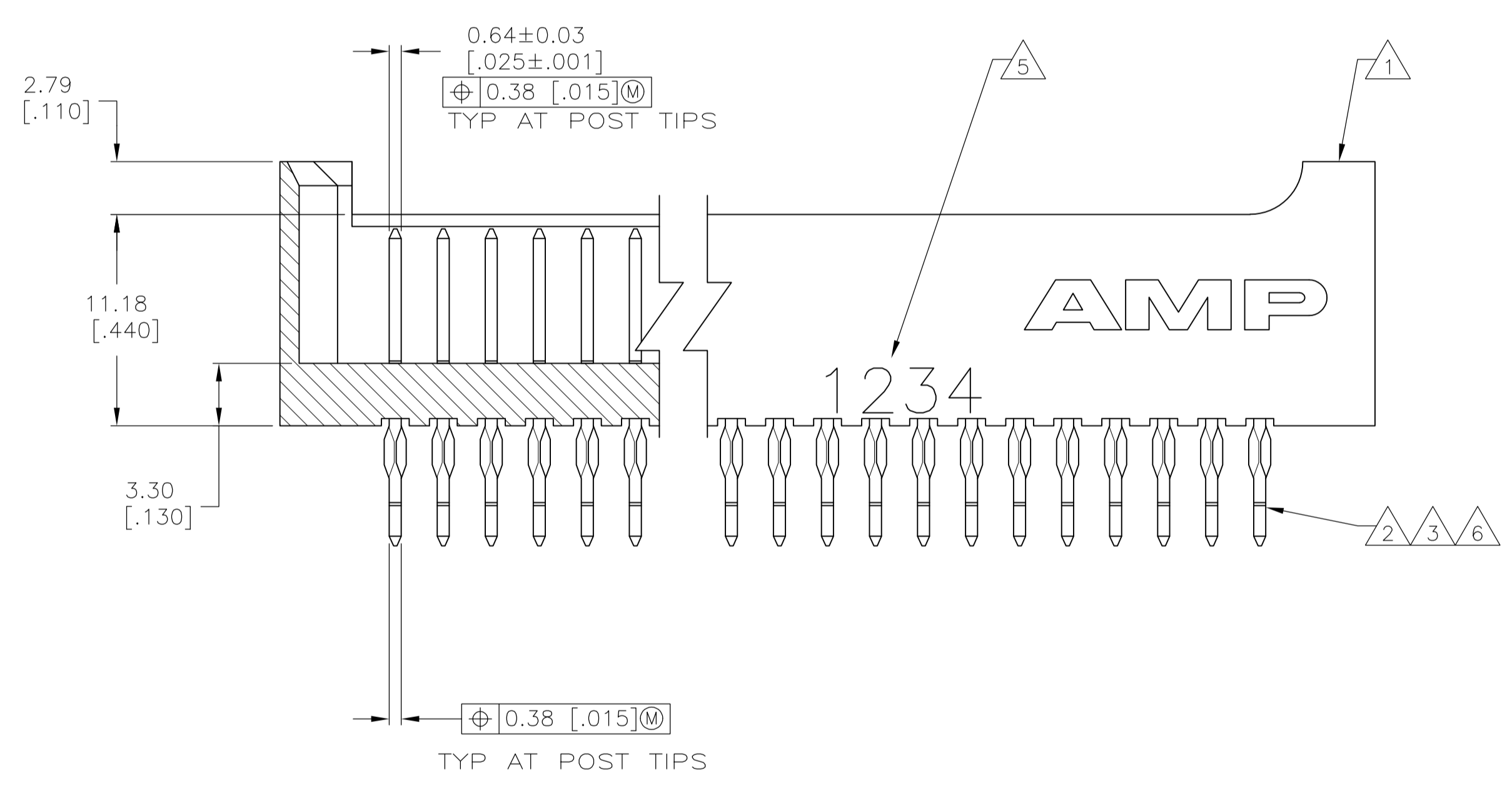

SECTION Z-Z
 ROTATED 90° CW

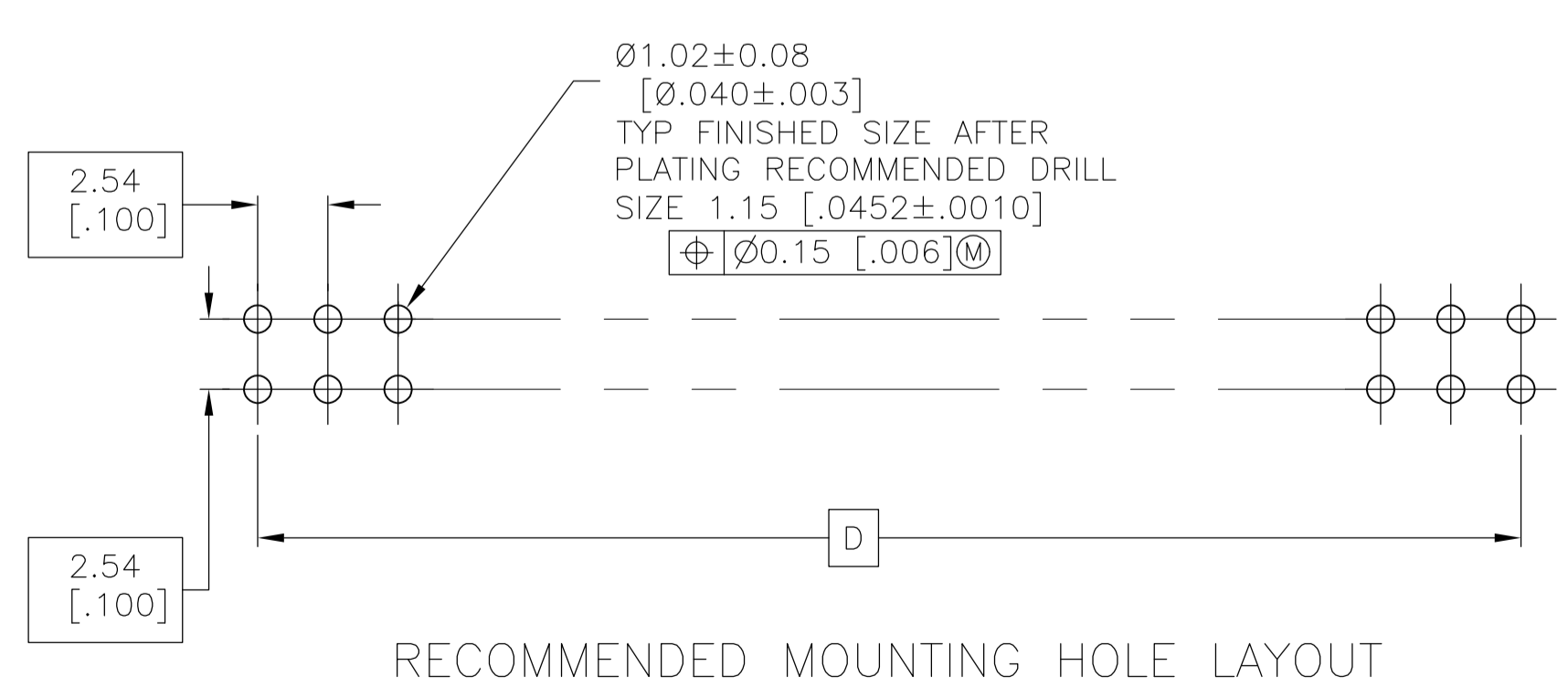

RECOMMENDED MOUNTING HOLE LAYOUT

THIS DRAWING IS A CONTROLLED DOCUMENT.		DIN K.L.CLOUSER/UTA 4/2/91	Tyco Electronics Corporation Harrisburg, PA 17105-3608	
DIMENSIONS: mm		CHK D SARVER	NAME HEADER ASSY, MOD II, DOUBLE ROW. 2.54 X 2.54 [.100 X .100]CL, .025 SQ COMPLIANT PIN POST, FOR .093 NOM AND THICKER BOARDS	
TOLERANCES UNLESS OTHERWISE SPECIFIED:		APVD	PRODUCT SPEC	
0 PLC ± -		APPLICATION SPEC		
1 PLC ± -		SIZE CAGE CODE DRAWING NO		
2 PLC ± 0.13 [.005]		WEIGHT		
3 PLC ± -		A1 00779 C=102690		
4 PLC ± -		CUSTOMER DRAWING		
ANGLES ± -		SCALE 4:1 SHEET 1 OF 2 REV L4		
MATERIAL 1 2		SEE TABLE		

OBSOLETE		210.06 [8.270]	200.66 [7.900]	79	210.82 [8.300]	212.85 [8.380]	160	7	7-102690-8
								7	7-102690-7
								7	7-102690-6
								7	7-102690-5
								7	7-102690-4
								7	7-102690-3
								7	7-102690-2
								7	7-102690-1
								7	7-102690-0
								7	6-102690-9
		98.30 [3.870]	88.90 [3.500]	35	22.86 [.900]	101.09 [3.980]	72	7	6-102690-8
OBSOLETE		95.76 [3.770]	86.36 [3.400]	34	96.52 [3.800]	98.55 [3.880]	70	7	6-102690-7
OBSOLETE	6	57.66 [2.270]	48.26 [1.900]	19	58.42 [2.300]	60.45 [2.380]	40	7	6-102690-6
OBSOLETE		44.96 [1.770]	35.56 [1.400]	14	45.72 [1.800]	47.75 [1.880]	30	7	6-102690-5
		27.18 [1.070]	17.78 [.700]	7	27.94 [1.100]	29.97 [1.180]	16	7	6-102690-4
OBSOLETE		32.26 [1.270]	22.86 [.900]	9	33.02 [1.300]	35.05 [1.380]	20	7	6-102690-3
OBSOLETE								7	6-102690-2
OBSOLETE		121.16 [4.770]	111.76 [4.400]	44	121.92 [4.800]	113.79 [4.480]	90	7	6-102690-1
OBSOLETE		260.86 [10.270]	251.46 [9.900]	99	261.62 [10.300]	263.65 [10.380]	200	7	6-102690-0
		159.26 [6.270]	149.86 [5.900]	59	160.02 [6.300]	162.05 [6.380]	120	7	5-102690-9
OBSOLETE		133.86 [5.270]	124.46 [4.900]	49	134.62 [5.300]	136.65 [5.380]	100	7	5-102690-8
		128.78 [5.070]	119.38 [4.700]	47	129.54 [5.100]	131.57 [5.180]	96	7	5-102690-7
		108.46 [4.270]	99.06 [3.900]	39	109.22 [4.300]	111.25 [4.380]	80	7	5-102690-6
		83.06 [3.270]	73.66 [2.900]	29	83.82 [3.300]	85.85 [3.380]	60	7	5-102690-5
		70.36 [2.770]	60.96 [2.400]	24	71.12 [2.800]	73.15 [2.880]	50	7	5-102690-4
OBSOLETE		52.58 [2.070]	43.18 [1.700]	17	53.34 [2.100]	55.37 [2.180]	36	7	5-102690-3
		37.34 [1.470]	27.94 [1.100]	11	38.10 [1.500]	40.13 [1.580]	24	7	5-102690-2
		22.10 [.870]	12.70 [.500]	5	22.86 [.900]	24.89 [.980]	12	7	5-102690-1
FINISH		E	D	C	B	A	NO OF POSN		PART NUMBER

OBSOLETE		210.06 [8.270]	200.66 [7.900]	79	210.82 [8.300]	212.85 [8.380]	160		2-102690-8
									2-102690-7
									2-102690-6
									2-102690-5
									2-102690-4
									2-102690-3
									2-102690-2
									2-102690-1
									2-102690-0
									1-102690-9
		98.30 [3.870]	88.90 [3.500]	35	22.86 [.900]	101.09 [3.980]	72		1-102690-8
OBSOLETE	8	95.76 [3.770]	86.36 [3.400]	34	96.52 [3.800]	98.55 [3.880]	70		1-102690-7
OBSOLETE	8	57.66 [2.270]	48.26 [1.900]	19	58.42 [2.300]	60.45 [2.380]	40		1-102690-6
OBSOLETE		44.96 [1.770]	35.56 [1.400]	14	45.72 [1.800]	47.75 [1.880]	30		1-102690-5
		27.18 [1.070]	17.78 [.700]	7	27.94 [1.100]	29.97 [1.180]	16		1-102690-4
		32.26 [1.270]	22.86 [.900]	9	33.02 [1.300]	35.05 [1.380]	20		1-102690-3
OBSOLETE									1-102690-2
		121.16 [4.770]	111.76 [4.400]	44	121.92 [4.800]	113.79 [4.480]	90		1-102690-1
OBSOLETE		260.86 [10.270]	251.46 [9.900]	99	261.62 [10.300]	263.65 [10.380]	200		1-102690-0
		159.26 [6.270]	149.86 [5.900]	59	160.02 [6.300]	162.05 [6.380]	120		102690-9
		133.86 [5.270]	124.46 [4.900]	49	134.62 [5.300]	136.65 [5.380]	100		102690-8
OBSOLETE	8	128.78 [5.070]	119.38 [4.700]	47	129.54 [5.100]	131.57 [5.180]	96		102690-7
		108.46 [4.270]	99.06 [3.900]	39	109.22 [4.300]	111.25 [4.380]	80		102690-6
		83.06 [3.270]	73.66 [2.900]	29	83.82 [3.300]	85.85 [3.380]	60		102690-5
		70.36 [2.770]	60.96 [2.400]	24	71.12 [2.800]	73.15 [2.880]	50		102690-4
OBSOLETE	8	52.58 [2.070]	43.18 [1.700]	17	53.34 [2.100]	55.37 [2.180]	36		102690-3
		37.34 [1.470]	27.94 [1.100]	11	38.10 [1.500]	40.13 [1.580]	24		102690-2
		22.10 [.870]	12.70 [.500]	5	22.86 [.900]	24.89 [.980]	12		102690-1
FINISH		E	D	C	B	A	NO OF POSN		PART NUMBER

THIS DRAWING IS A CONTROLLED DOCUMENT. DWN: K.L.CLOUSER/UTA 4/2/91
 CHK: D SARVER 6-19-91
 Tyco Electronics Corporation
 Harrisburg, PA 17105-3608

DIMENSIONS: mm	TOLERANCES UNLESS OTHERWISE SPECIFIED:	APVD	NAME
0. PLC ± .01	1. PLC ± .01	—	—
2. PLC ± .015 [0.05]	3. PLC ± .015 [0.05]	—	—
4. PLC ± .015 [0.05]	ANGLES ± .5	—	—

MATERIAL: FINISH SEE TABLE WEIGHT: — SIZE: A1 CAGE CODE: 00779 DRAWING NO: 102690 RESTRICTED TO: —
 CUSTOMER DRAWING SCALE: 4:1 SHEET 2 OF 2 REV 14