

P	LTR	DESCRIPTION	DATE	DWN	APVD
B		NEW VARIANT ADDED	24NOV2016	W SA	DHV
C		PN 9-2177090-1/-2/-3 Obsolete	27SEP2017	CR	DHV
C1		PN 0-2177090-5 in Tabelle hinzu	23MAR2018	CR	DHV
C2		New PN 0-2177090-6 added in table	08MAY2019	JJH	TSV

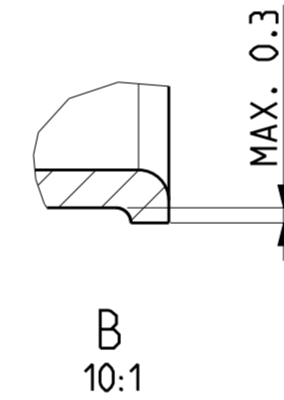
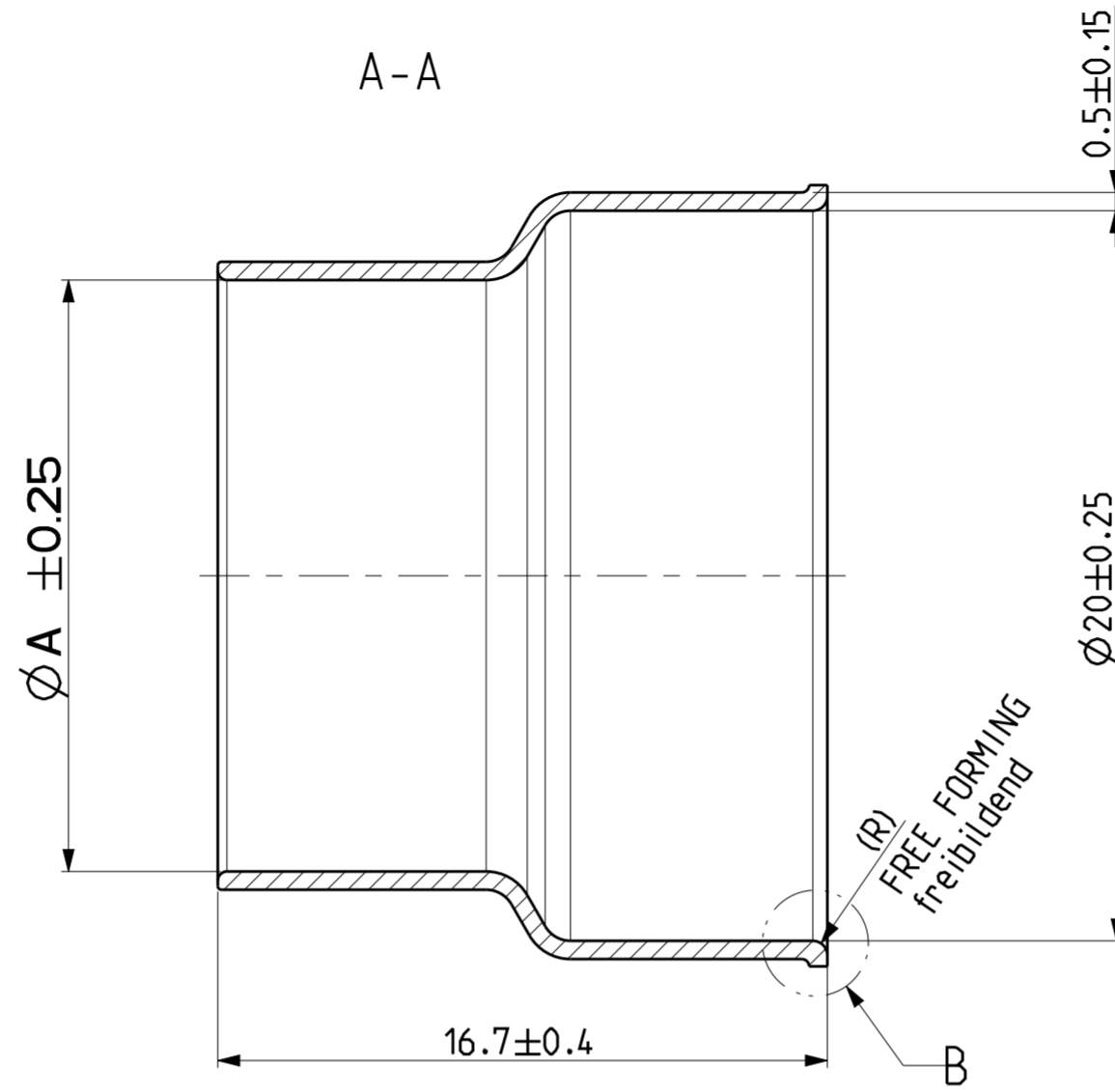
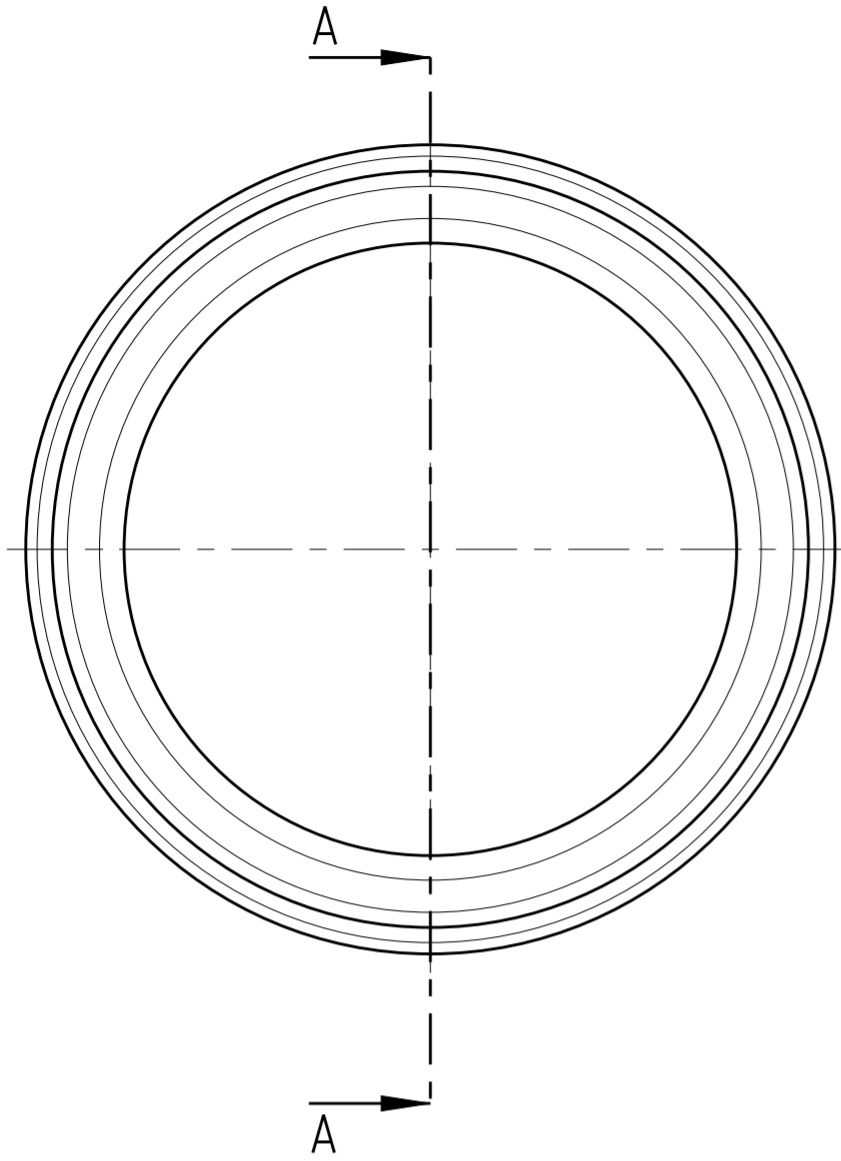

- ONLY THE GERMAN LANGUAGE IS AUTHORITATIVE
Massgebend ist der deutsche Text
- PACKAGING: BULK PACKAGING IN SHIPPING BOX
Verpackung: Schuettgut in Versandkarton

NOTE Bem.	FEATURE Merkmal
3	PRODUCT-SPEC. 108-94297 Produkt-Spez.
4	APPLICATION-SPEC. 114-94130 Verarbeitungs-Spez.

0-2177090-6	A	SHIELD CRIMP FERRULE Schirm Crimphuelse	15.6	50mm ² General Cable Prestolite ES-2364 for FCA Specific	STAINLESS STEEL 1.4301 Edelstahl 1.4301	4.0	BLANK blank
0-2177090-5	A		13.6	35mm ² Prestolite			
0-2177090-4	A		10.5	16			
0-2177090-3	A		12.5	25			
0-2177090-2	A		14.8	35			
0-2177090-1	A		16.2	50			
TE-ORDER-NO. TE-Bestell-Nr.	REV	DESCRIPTION Benennung	DIMENSION A Mass A	FOR / fuer WIRE SIZE [MM ²] Leitungsquers. [mm ²]	MATERIAL	WEIGHT Gewicht [g]	SURFACE Oberflaeche

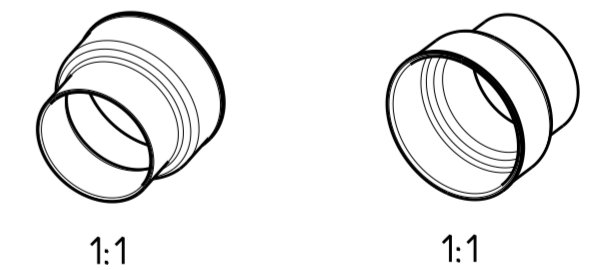
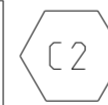

0- -1 AS SHOWN
wie gezeichnet

PRODUCT CHARACTERISTICS ACC. QMP_EMEA_012 BESONDERE MERKMALE NACH QMP_EMEA_012		TOLERANCING ISO 8015 TOLERIERUNG ISO 8015	
THIS DRAWING IS A CONTROLLED DOCUMENT.		DWN I.Salman 06MAY2011	TE Connectivity
DIMENSIONS: mm		CHK U.Hoepfner 09MAY2011	
TOLERANCES UNLESS OTHERWISE SPECIFIED: DIN ISO 2768-mK		APVD D.H.VU 09MAY2011	
MATERIAL		PRODUCT SPEC	NAME SHIELD CRIMP FERRULE Schirm Crimphuelse
FINISH		APPLIC. SPEC	SIZE A2
finish_spec_2		WEIGHT	CAGE CODE 00779
		CUSTOMER DRAWING	DRAWING NO C-2177090
		SCALE 5:1	RESTRICTED TO
		SHEET 1 OF 2	REV C2

REVISIONS					
P	LTR	DESCRIPTION	DATE	DWN	APVD
-		SEE SHEET 1	-	-	-

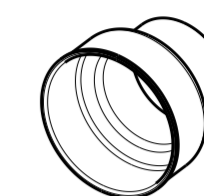

1:1

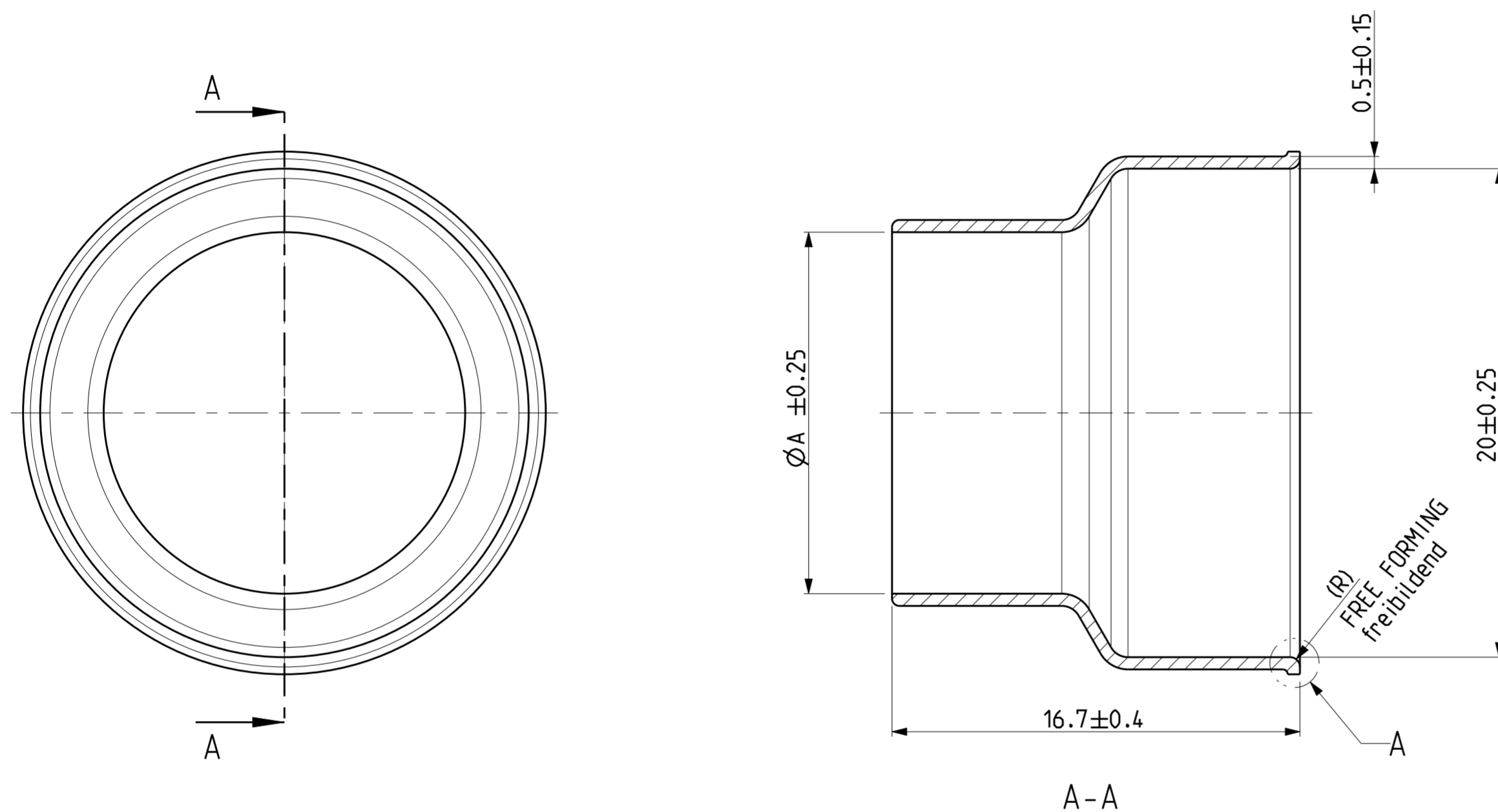

NOTES:

Bemerkungen:

- 1 ONLY THE GERMAN LANGUAGE IS AUTHORITATIVE
Maßgebend ist der deutsche Text
- 2 PACKAGING: BULK PACKAGING IN SHIPPING BOX
Verpackung: Schuetftgut in Versandkarton

OBSOLETE

NOTE Bem.	FEATURE Merkmal
3	PRODUCT-SPEC. 108-94297 Produkt-Spez.
4	APPLICATION-SPEC. 114-94130 Verarbeitungs-Spez.

9-2177090-3	1		12.5	25			
9-2177090-2	1	SHIELD CRIMP FERRULE Schirm Crimphuelse	14.8	35	STAINLESS STEEL 1.4301 Edelstahl 1.4301	4	BLANK blank
9-2177090-1	1		16.2	50			
TE-ORDER-NO. TE-Bestell-Nr.	REV	DESCRIPTION Benennung	DIMENSION A Mass A	FOR / fuer WIRE SIZE [MM ²] Leitungsquers. [mm ²]	MATERIAL	WEIGHT [G] Gewicht [g]	SURFACE Oberflaeche

PRODUCT CHARACTERISTICS ACC. QMP.EMEA.012 BESONDERE MERKMALE NACH QMP.EMEA.012		TOLERANCING ISO 8015 TOLERIERUNG ISO 8015	
THIS DRAWING IS A CONTROLLED DOCUMENT.		DWN I.Salman 06MAY2011	TE Connectivity
		CHK U.Hoepfner 09MAY2011	
		APVD D.H.VU. 09MAY2011	
DIMENSIONS: mm		TOLERANCES UNLESS OTHERWISE SPECIFIED: 0 PLC ± 1 PLC ± 2 PLC ± 3 PLC ± 4 PLC ± ANGLES ±° FINISH -	
MATERIAL -		PRODUCT SPEC 3 APPLICATION SPEC 4 WEIGHT -	
-		finish_spec_2	
CUSTOMER DRAWING		NAME SHIELD CRIMP FERRULE Schirm Crimphuelse SIZE A2 CAGE CODE 00779 DRAWING NO C-2177090 RESTRICTED TO SCALE 5:1 SHEET 2 OF 2 REV C2	