

Universal Timer Controller

Features

- Auto-shut off output once time-out
- Button to ON/OFF/RESET timer
- Available timer with high precision same as AC 50/60hz
- Build-in RC oscillator
- Drive external RELAY
- Support 50/60Hz by part
- Quick Test Mode (QTM) for manufacturer
- Available timer of 15/30/45/60/90/120/240/480min
- Buzzer function(PT8A2524/25/34/35/44/45 Optional)
- Low cost lead free package: TO94-4 or DIP-8 or SOIC-8

Description

Universal timer is a mixed signal CMOS IC designed for a fixed timer to drive external RELAY to implement safety power control. It is applied to 120V/240V and 50/60Hz AC power supply. It can automatically shut-off load in order to prevent undesired conditions from the system. Internal timer can present several kinds of different time: 15mins, 30mins, 45mins, 1hr, 1.5hrs, 2hrs, 4hrs and 8hrs, which is decided by part number.

Applications

- Universal Timer Controller

Pin Configuration

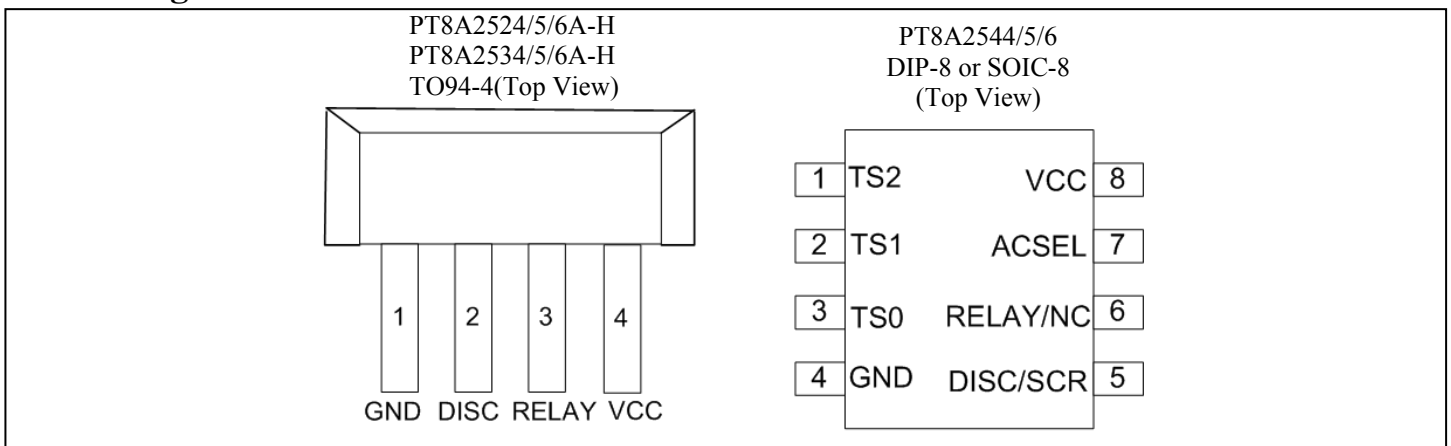

Pin Description

PT8A2524/5/6A-H, PT8A2534/5/6A-H

Pin Name	Pin No	I/O	Pin Description
GND	1	-	Ground
DISC	2	I/O	Control output if discharging external capacitor and button input, high active
RELAY	3	I/O	RELAY output and button input, high active
VCC	4	-	Power supply

PT8A2544/5/6

Pin Name	Pin No.	I/O	Pin Description
TS2	1	I	Timer selection pins(TS2 TS1 TS0 from 000~111) 000: 15m, 001: 30m, 010: 45m, 011: 60m, 100: 90m, 101: 120m,110: 240m,111: 480m Default 011 by TS2 internal pull down, TS1&TS0 internal pull up
TS1	2	I	
TS0	3	I	
GND	4	-	Ground
DISC	5	I/O	Control output if discharging external capacitor and button input, high active
RELAY	6	I/O	RELAY output and button input, high active
ACSEL	7	I	50/60Hz selection pin: default is 60Hz by internal pull down; connecting to VCC is 50Hz.
VCC	8	-	Power supply

Maximum Ratings

Storage Temperature.....	-40°C to +125°C
Supply Voltage to Ground Potential (Input & V _{CC} Only).....	-0.5V to V _{CC} +0.5V
Supply Voltage to Ground Potential (Outputs & D/O Only).....	-0.5V to V _{CC} +0.5V
DC Input Voltage	-0.5V to V _{CC} +0.5V
DC Output Current.....	20mA
Power Dissipation.....	500mW

Note:

Stresses greater than those listed under MAXIMUM RATINGS may cause permanent damage to the device. This is a stress rating only and functional operation of the device at these or any other conditions above those indicated in the operational sections of this specification is not implied. Exposure to absolute maximum rating conditions for extended periods may affect reliability.

Recommended operation conditions

Symbol	Parameter	Min	Typ	Max	Unit
V _{CC}	Operating Voltage	4.2	4.7	5.2	V
T _A	Operating temperature	0	25	85	°C

Electrical Characteristics

Sym	Parameter	Test Conditions		Min	Typ	Max	Unit
		V _{CC}	Condition				
V _{CC}	Shunt Regulator output voltage	-	I _{CC} = 1mA	4.2	4.7	5.2	V
V _{TH}	Input threshold(RELAY/DISC)	5V	-	0.3	0.35	0.4	V
I _{OH}	Output Source Current (RELAY/DISC)	5V	V _{OH} =0.7V	-0.3	-0.5	-1	mA
I _{OL}	Output Sink Current (RELAY/DISC)	5V	V _{OL} =0.5V	0.5	-	-	mA
I _{CC}	Power supply current	4.0V	-	-	-	0.5	mA
F _{OSC}	Frequency of internal oscillator	5V	-	96	128	160	KHz

Block Diagram

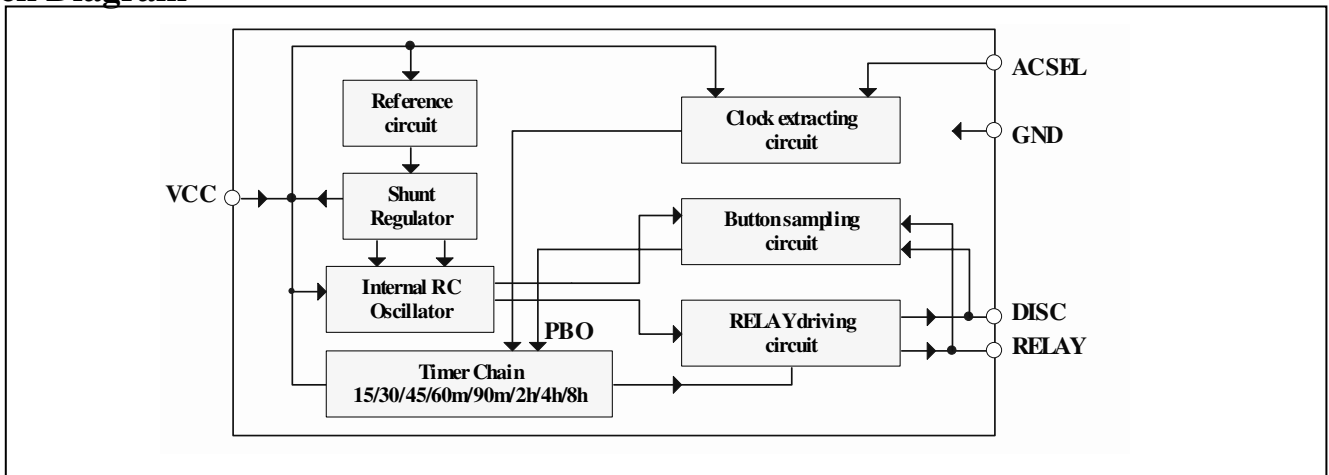

Functional Description (Note: In below description, “RELAY” presents a pin, while “relay” means a device.)

● **Clock extracting circuit**

VCC is not only the power supply pin but also clock source for internal precise timer. With the help of the external circuit, the AC 50/60Hz clock signal can be extracted to be used as timer clock source.

● **Internal RC oscillator circuit**

It is employed to create pulse driving signal for RELAY, it is a completely internal RC oscillator with frequency of about 128KHZ.

● **Timer chain**

Timer chain can be used to generate various timer including 15/30/45/60/90/120/240/480min.

● **Button sampling circuit**

With external buttons, ON/OFF/RESET function can be realized. User can select one button with once ON, once OFF or two buttons to turn ON or OFF separately, also use one button to restart timer.

Button sampling circuit senses button’s operation 3 times per 8ms. System will sample the button’s operation during first 100ms after power on, if buttons are pressed during this period, then system will start 3s timer to check if the chip will enter into quick test mode (see test mode section). If the related button is pressed over 3s just after power on, chip will enter quick test mode as soon as the button is released. If buttons are not pressed during first 100ms, system will operate normally.

● **RELAY driving circuit**

RELAY driving signal is special, anytime, first 8ms is always high following output pulse signal with about 32KHZ and 25% duty cycle.

DISC is used to limit the voltage of external high voltage capacitor by discharging it with a NPN transistor.

After power on, DISC should be active during first 1s before RELAY in order to charge the external high voltage capacitor.

RELAY is active to output first 8ms high following 32KHZ with 25% duty cycle. When relay is OFF, RELAY will output a narrow pulse each 8ms, while, DISC is active to output 32KHZ with 25% duty cycle.

For PT8A2524/2534 one button (RESET)

- Button is tied to RELAY pin.
- Pressing button RESET to turn on relay and restart internal timer.
- RELAY is active once the button is released.
- DISC will output low when relay is ON.

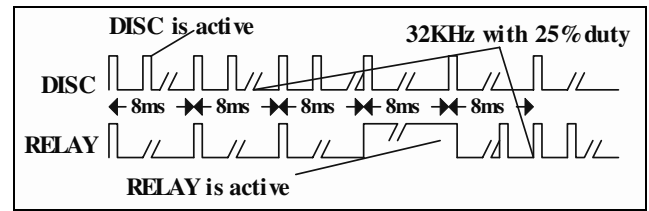

Driving signals of RELAY and DISC

For PT8A2525/2535 one button (ON/OFF)

- Button is tied to RELAY pin, once ON, once OFF.
- Pressing button ON/OFF to turn on/off relay and start/reset internal timer.
- RELAY is active when the button is pressed at first time.
- DISC is active when the button is pressed at second time.
- DISC outputs Low when relay is ON.

For PT8A2526/2536 two buttons (ON, OFF)

- Button tied to DISC pin is for ON, Button tied to RELAY pin is for OFF.
- Pressing button ON to turn on relay and start internal timer.
- Pressing button OFF to turn off relay and reset internal timer.
- RELAY is active when button ON is pressed.
- DISC is active when button OFF is pressed.
- DISC will output a narrow pulse each 8ms when relay is ON.

● **Buzzer**

For PT8A2524/25/34/35/44/45, a buzzer will make 0.5s sound with a frequency of 4KHz every 1s for 6 times after internal timer times out. Pin DISC will output 4KHz with 25% duty for 0.5s to let the buzzer work, then output 32KHz with 25% duty for 0.5s, after the output 6 times 4KHz, DISC will keep output 32KHz.

● **Quick Test Mode(QTM)**

In order to make the manufacturer’s test convenient, quick test mode is designed to speed up the test.

QTM can be accessed by pressing button (ON or RESET) over 3s (option 2s) once power on. It can exit automatically after quick test timer is expired, system needs to power on again to come back normal operation after quick test mode. Any button operations will be ignored in QTM.

Note: For PT8A2526/2536, the button to be pressed over 3s to enter into QTM is OFF.

Operation illustration of entering into and exiting Quick test mode

Compare Table: Real timer and QTM timer

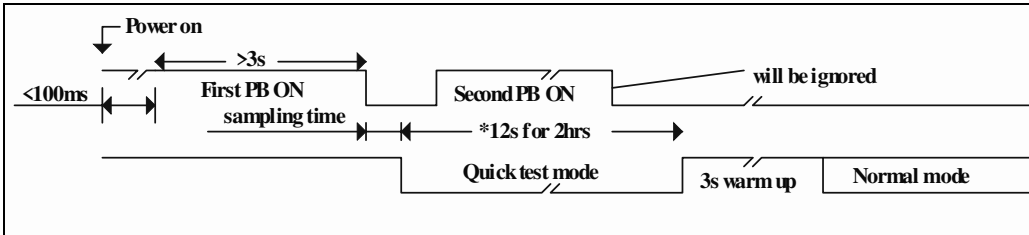

Real Timer	QTM Timer
15m	2s
30m	4s
45m	6s
60m	8s
90m	10s
120m	12s
4h	14s
8h	16s

Application Circuit

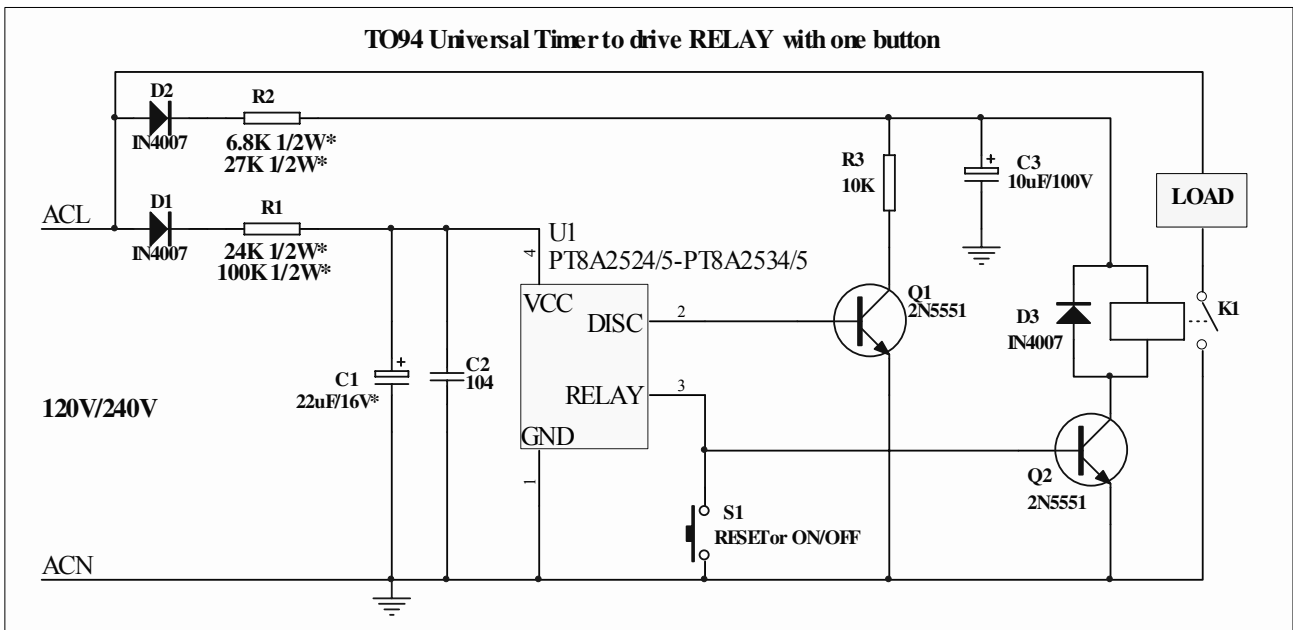

***Note1:** For 120VAC power supply system, R1 value is 24K, R2 value is 6.8K.
For 240VAC power supply system, R1 value is 100K, R2 value is 27K.

Note2: C1 value range is 22uF to 68uF.

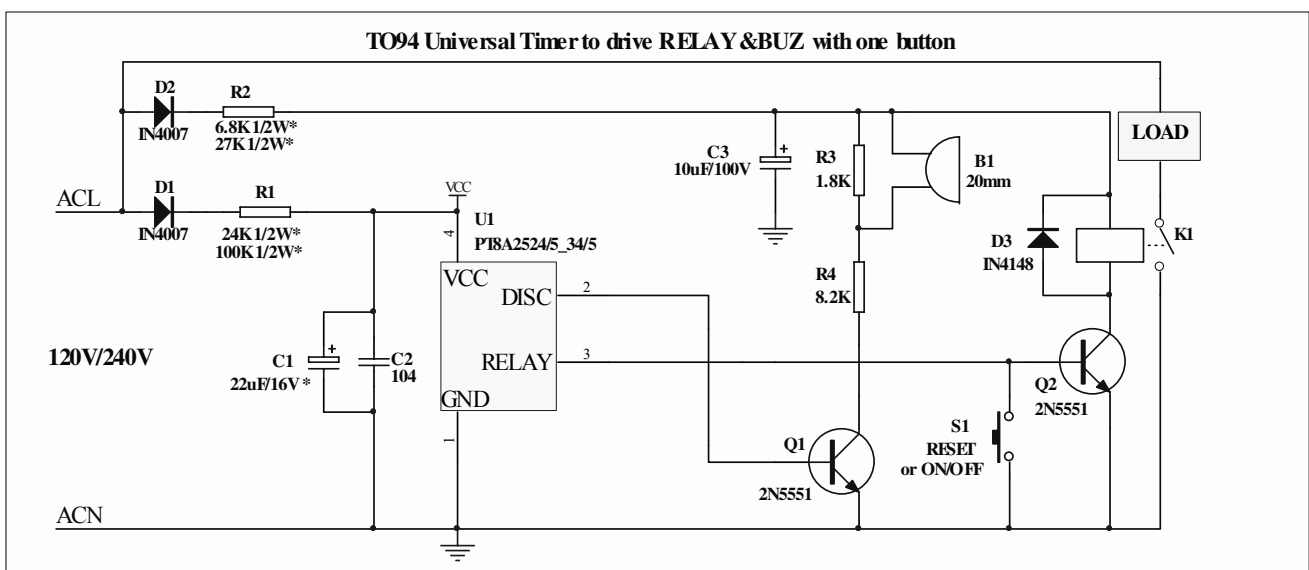

***Note1:** For 120VAC power supply system, R1 value is 24K, R2 value is 6.8K.
For 240VAC power supply system, R1 value is 100K, R2 value is 27K.

Note2: C1 value range is 22uF to 68uF.

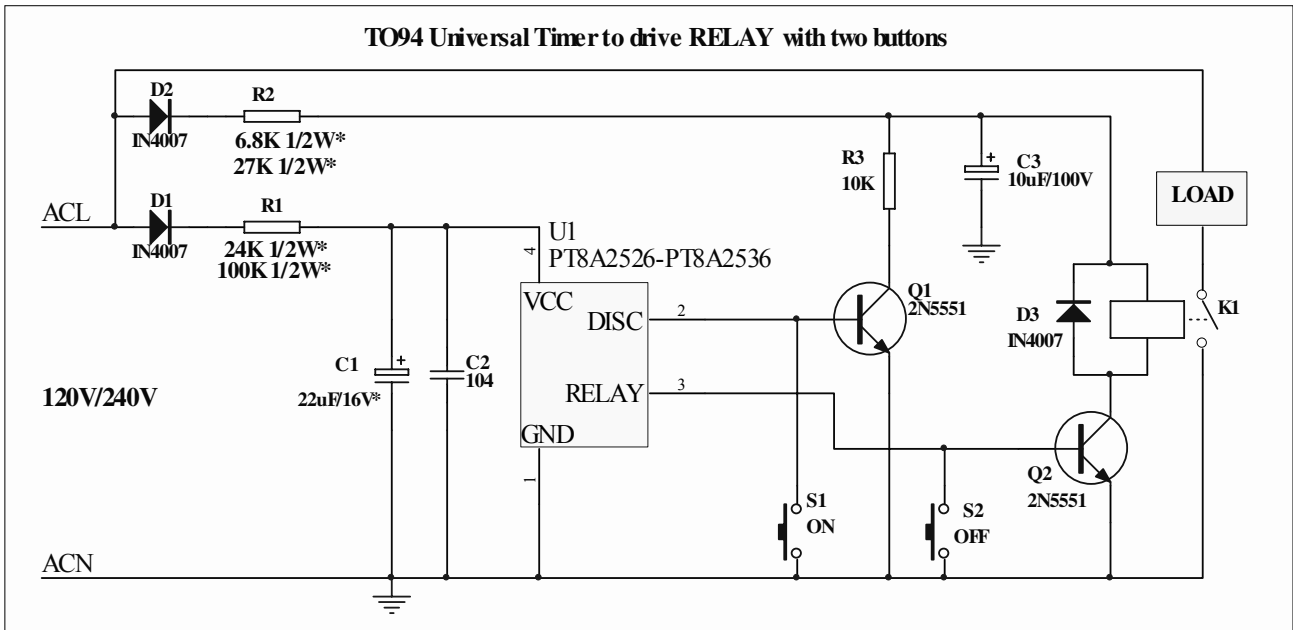

***Note1:** For 120VAC power supply system, R1 value is 24K, R2 value is 6.8K.
For 240VAC power supply system, R1 value is 100K, R2 value is 27K.

Note2: C1 value range is 22uF to 68uF.

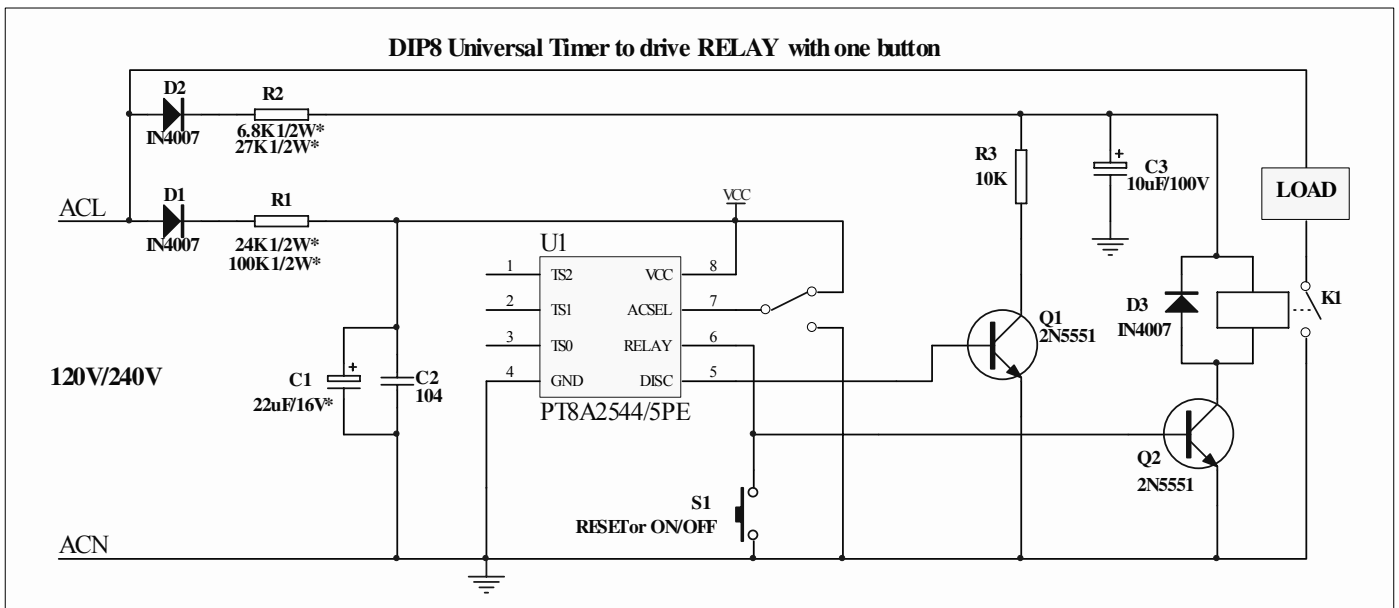

***Note1:** For 120VAC/60Hz power supply system, R1 value is 24K, R2 value is 6.8K, ACSEL is connected to GND or floating.

For 240VAC/50Hz power supply system, R1 value is 100K, R2 value is 27K, ACSEL is connected to VCC.

***Note2:** TS0, TS1 and TS2 are floating, the timer time out is 60 minutes.

Note3: C1 value range is 22uF to 68uF.

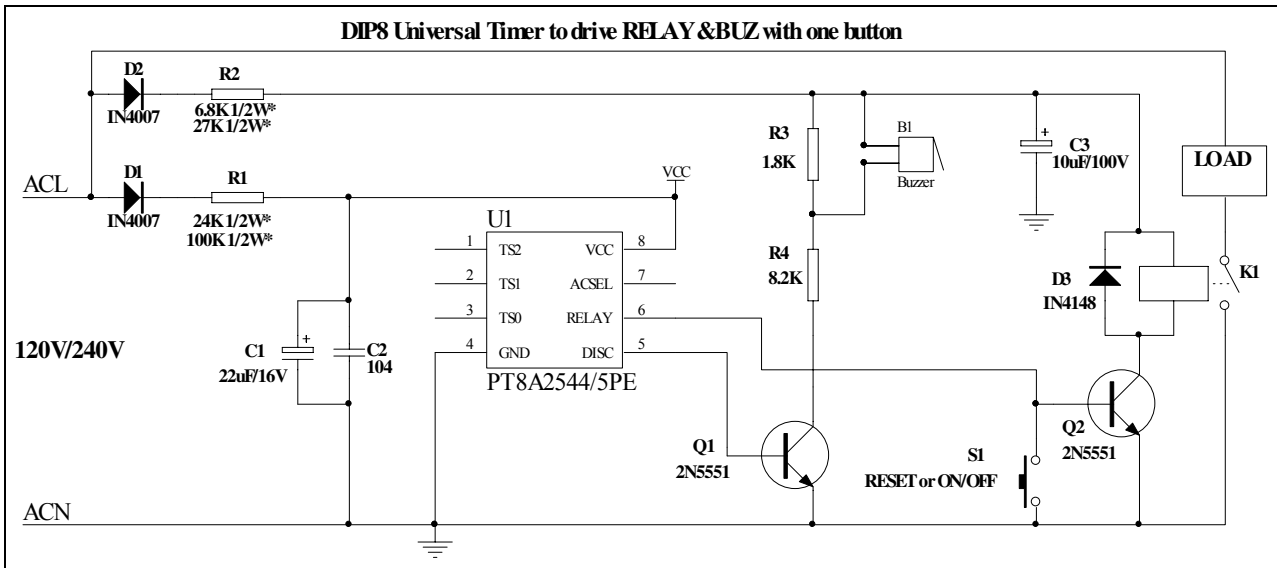

- *Note1: For 120VAC/60Hz power supply system, R1 value is 24K, R2 value is 6.8K, ACSEL is connected to GND or floating.
For 240VAC/50Hz power supply system, R1 value is 100K, R2 value is 27K, ACSEL is connected to VCC.
- *Note2: TS0, TS1 and TS2 are floating, the timer time out is 60 minutes.
- Note3: C1 value range is 22uF to 68uF.

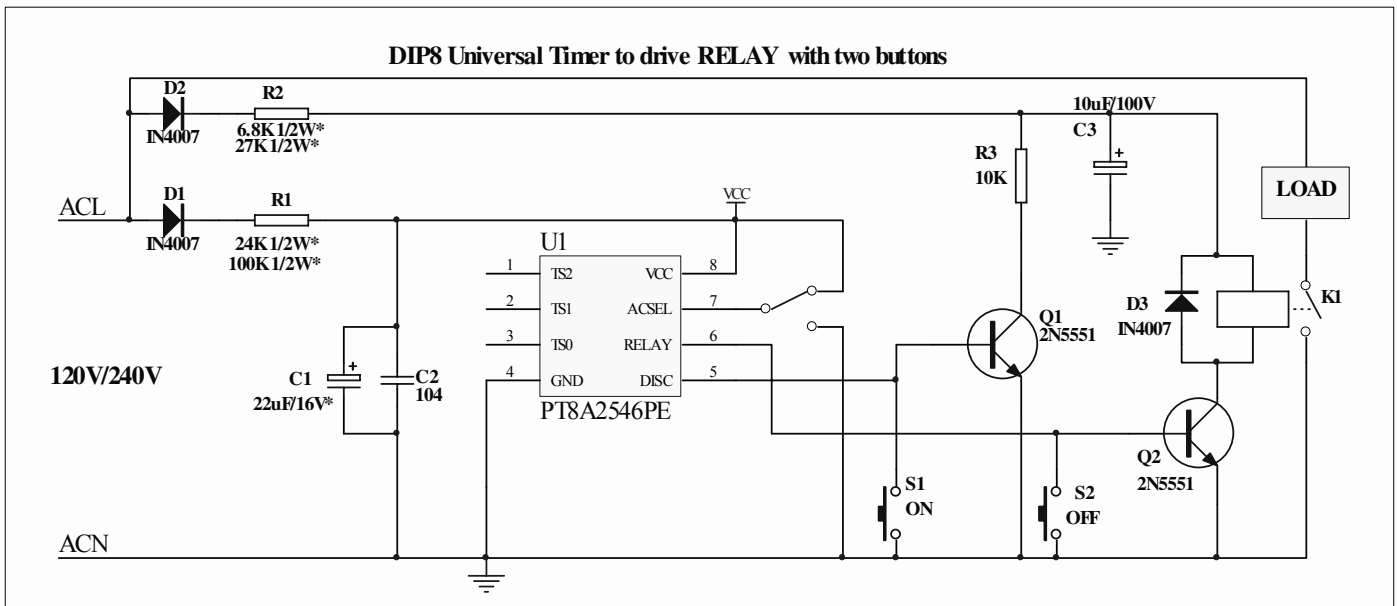

- *Note1: For 120VAC/60Hz power supply system, R1 value is 24K, R2 value is 6.8K, ACSEL is connected to GND or floating.
For 240VAC/50Hz power supply system, R1 value is 100K, R2 value is 27K, ACSEL is connected to VCC.
- *Note2: TS0, TS1 and TS2 are floating, the timer time out is 60 minutes.
- Note3: C1 value range is 22uF to 68uF.

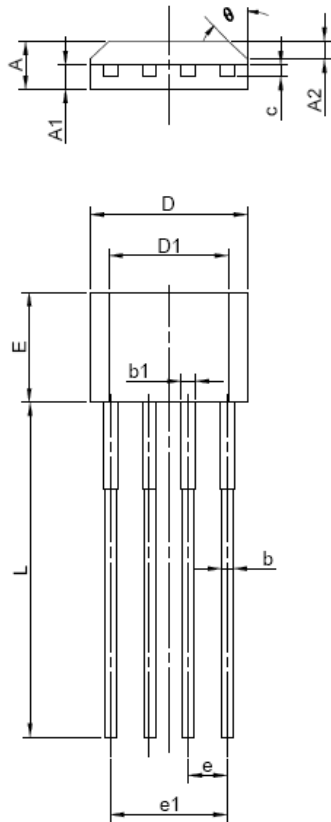
Mechanical Information
TO94-4L

PKG. DIMENSIONS(MM)		
SYMBOL	Min	Max
A	1.40	1.80
A1	0.70	0.90
b	0.36	0.50
b1	0.38	0.55
c	0.36	0.51
D	4.98	5.28
D1	3.78	4.08
e	1.27 TYP	
E	3.45	3.75
e1	3.71	3.91
L	14.90	15.30
θ	45° BSC	

Note:



DATE: 06/18/13

DESCRIPTION: 4-Pin, TO94

PACKAGE CODE: N (N4)

DOCUMENT CONTROL #: PD-2150

REVISION: --

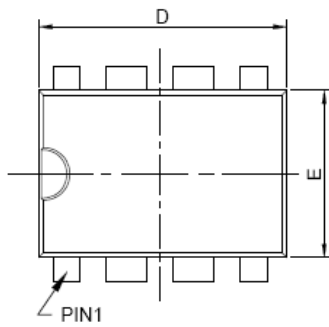
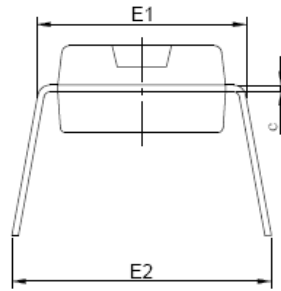
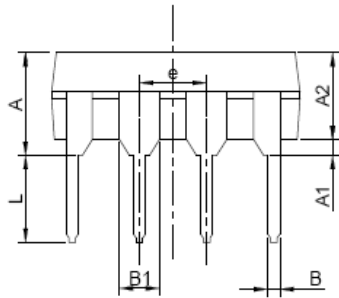
DIP-8L

PKG. DIMENSIONS(MM)		
SYMBOL	Min	Max
A	3.71	4.31
A1	0.51	
A2	3.20	3.80
B	0.38	0.57
B1	1.52 BSC	
c	0.20	0.36
D	9.00	9.40
E	6.20	6.80
E1	7.32	7.92
e	2.54 BSC	
L	3.00	3.80
E2	8.40	9.00

Notes:

1. Refer JEDEC MS-001D/BA



DATE: 06/14/13

DESCRIPTION: 8-Pin, Dual InLine Plastic, DIP

PACKAGE CODE: P (P8)

DOCUMENT CONTROL#: PD-2134

REVISION: --

SOIC-8L
DOCUMENT CONTROL NO.
 PD - 1001

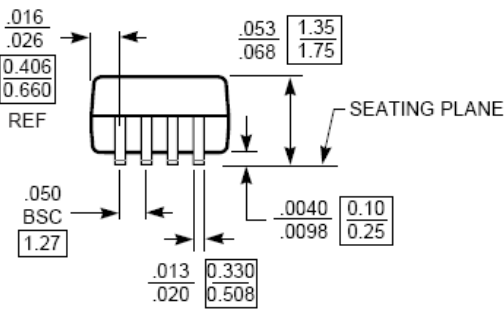
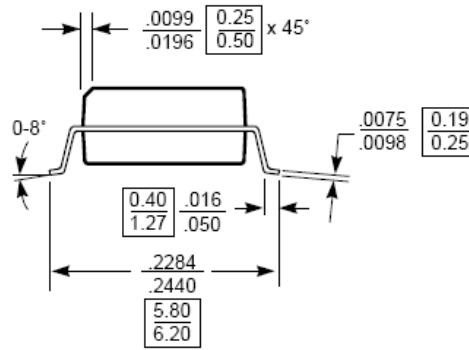
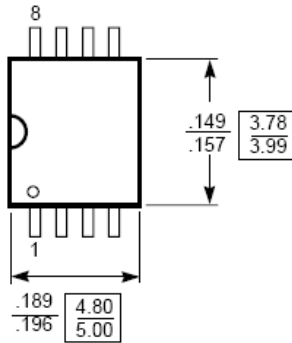
REVISION: E
DATE: 07/06/99

X.XX	DENOTES DIMENSIONS
X.XX	IN MILLIMETERS

Notes:
 1) Controlling dimensions in millimeters.
 2) Ref. JEDEC MS - 012 AA

 Pericom Semiconductor Corporation
 2380 Bering Drive, San Jose, CA 95131
 Tel: (408) 435-0800 • Fax: (408) 435-1100

DESCRIPTION: 8-PIN SOIC (150 MIL WIDE)
PACKAGE CODE: W8

Ordering Information

Ordering No.	Package Code	Package
PT8A2524xNE*	N	Lead free TO-94
PT8A2525xNE*	N	Lead free TO-94
PT8A2526xNE*	N	Lead free TO-94
PT8A2534xNE*	N	Lead free TO-94
PT8A2535xNE*	N	Lead free TO-94
PT8A2536xNE*	N	Lead free TO-94
PT8A2544PE*	P	Lead free DIP-8
PT8A2545PE*	P	Lead free DIP-8
PT8A2546PE*	P	Lead free DIP-8
PT8A2544WE	W	Lead free and Green SOIC-8
PT8A2545WE	W	Lead free and Green SOIC-8
PT8A2546WE*	W	Lead free and Green SOIC-8

Note:

- “x” shows A~H with different Internal Timer, see below Suffix x: Internal Timer table.
- E = Pb-free or Pb-free & Green
- Adding X Suffix= Tape/Reel
- *contact Pericom for availability.

Function Comparison Table

Part No	One/Two key	Button	50/60 Hz	Part No	One/Two key	Button	50/60 Hz
PT8A2524x	One	Reset	50HZ	PT8A2534x	One	Reset	60HZ
PT8A2525x	One	On/Off	50HZ	PT8A2535x	One	On/Off	60HZ
PT8A2526x	Two	On, Off	50HZ	PT8A2536x	Two	On, Off	60HZ

Part No	One/Two key	Button	50/60 Hz	Timer(min)
PT8A2544	One	Reset	Optional	Optional
PT8A2545	One	On/Off	Optional	Optional
PT8A2546	Two	On, Off	Optional	Optional

Suffix x: Internal Timer Table

Suffix	A	B	C	D	E	F	G	H
Internal Timer(min)	15	30	45	60	90	120	240	480

Pericom Semiconductor Corporation • 1-800-435-2336 • www.pericom.com

Pericom reserves the right to make changes to its products or specifications at any time, without notice, in order to improve design or performance and to supply the best possible product. Pericom does not assume any responsibility for use of any circuitry described other than the circuitry embodied in Pericom product. The company makes no representations that circuitry described herein is free from patent infringement or other rights, of Pericom.