

DATE CODE ALLEN-BRADLEY (B)			
EVEN	ODD	YEARS	
1974	MONTH	1995	
A	JAN	N	A-2012+2013
B	FEB	O	B-2014+2015
C	MAR	P	C-2016+2017
D	APR	R	D-2018+2019
E	MAY	S	E-2020+2021
F	JUN	T	F-2022+2023
G	JUL	U	G-2024+2025
H	AUG	V	H-2026+2027
I	SEP	W	I-2028+2029
J	OCT	X	J-2030+2031
K	NOV	Y	K-2032+2033
L	DEC	Z	L-2034+2035
M			M-2036+2037
			N-2038+2039
			O-2040+2041
			P-2042+2043
			Q-2044+2045
			R-2046+2047
			S-2048+2049
			T-2050+2051
			U-2052+2053
			V-2054+2055
			W-2056+2057
			X-2058+2059
			Y-2060+2061
			Z-2062+2063

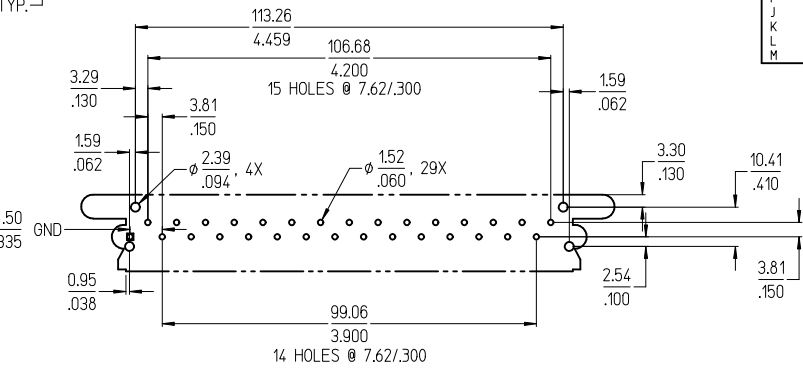
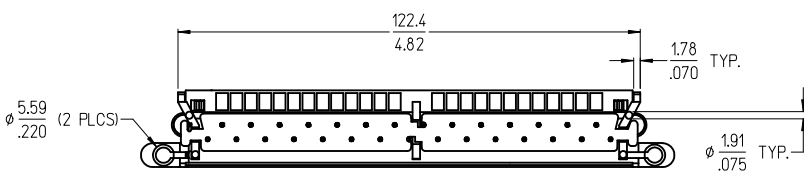

- NOTES:
1. MATERIAL: SEE TABLE
 2. PIN ORGANIZERS MAY TWIST, WARP, BOW AND/OR OTHERWISE DEFLECT.
 3. TAIL LOCATIONS TOLERANCE IS $\pm 0.51 \pm 0.20$ W/PIN ORGANIZER INSTALLED.
 4. ASSEMBLY IS ROHS COMPLIANT.
 5. REPLACES DWG# SD-39939-0010. (B)

RECOMMENDED PTH PATTERN

ITEM	QTY.	DESCRIPTION	MATERIAL	FINISH
13	2	THREADED NUT INSERT	BRASS	NICKEL
12	13	REAR PIN	HPA COPPER	SELECTIVE GOLD/NICKEL
11	12	FRONT PIN	HPA COPPER	SELECTIVE GOLD/NICKEL
10	1	HEADER HOUSING	NYLON (PAI) 66/6	GRAY
9	2	RETAINER CLIP	STEEL	ZN/CLEAR CHROMATE
8	2	JACKING SCREW, M2.5, PAN, PH/SL	STEEL	NICKEL/COPPER
7	25	SCREW&WASHER, WIRING, M3, PAN, PH/SL	STEEL	NICKEL/COPPER
6	25	NUT	STEEL	ZN/YELLOW CHROMATE
5	13	LONG PLUG TERMINAL	BERYLLIUM COPPER	SELECTIVE GOLD/NICKEL
4	12	SHORT PLUG TERMINAL	BERYLLIUM COPPER	SELECTIVE GOLD/NICKEL
3	1	PIN ORGANIZER	POLYESTER	WHITE
2	1	COVER, FRONT ROW	POLYCARBONATE	CLEAR
1	1	PLUG HOUSING	NYLON (PAI) 66/6	GRAY

UPDATE DATE CODE TABLE
 EC NO: IFC2012-0311
 DRWN: ENC INAS 2012/02/01
 CHKD: JMACNEIL
 APPR: JMACNEIL 2012/03/20

QUALITY SYMBOLS
 ▽=0
 ▽=0

GENERAL TOLERANCES (UNLESS SPECIFIED)

	mm	INCH
4 PLACES	± .---	± .---
3 PLACES	± .---	± .005
2 PLACES	± 0.13	± .01
1 PLACE	± 0.3	± .---

ANGULAR ± 2 °

DRAFT WHERE APPLICABLE MUST REMAIN WITHIN DIMENSIONS

DIMENSION STYLE
 MM/IN

DRAWN BY DATE
 S. GILBERT 2000/12/04

CHECKED BY DATE
 P. WALTZ 2001/04/09

APPROVED BY DATE
 JMACNEIL 2012/03/20

MATERIAL NO.
 399390010

SCALE 1:1
 DESIGN UNITS INCH
 THIRD ANGLE PROJECTION

TITLE
 DR BTS PLUG & HEADER W/
 PIN ORGANIZER 29 ASSY.

MOLEX MOLEX INCORPORATED

DOCUMENT NO. SD-39939-008
 SHEET NO. 1 OF 1

THIS DRAWING CONTAINS INFORMATION THAT IS PROPRIETARY TO MOLEX INCORPORATED AND SHOULD NOT BE USED WITHOUT WRITTEN PERMISSION