

REVISIONS					
P	LTR	DESCRIPTION	DATE	DWN	APVD
F13		PN 6-796640-6 RELEASED FOR PRODUCTION	04DEC2018	RK	PS
F14		6-796640-6 PART OBSOLETE	28AUG2020	DV	PS
F15		4-796640-1 MADE OBSOLETE	27DEC2021	SCB	PS

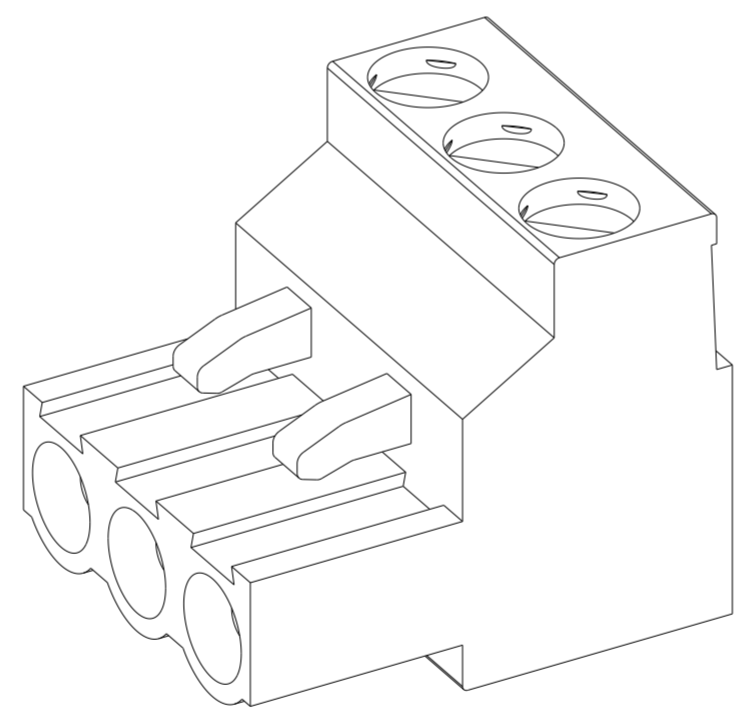
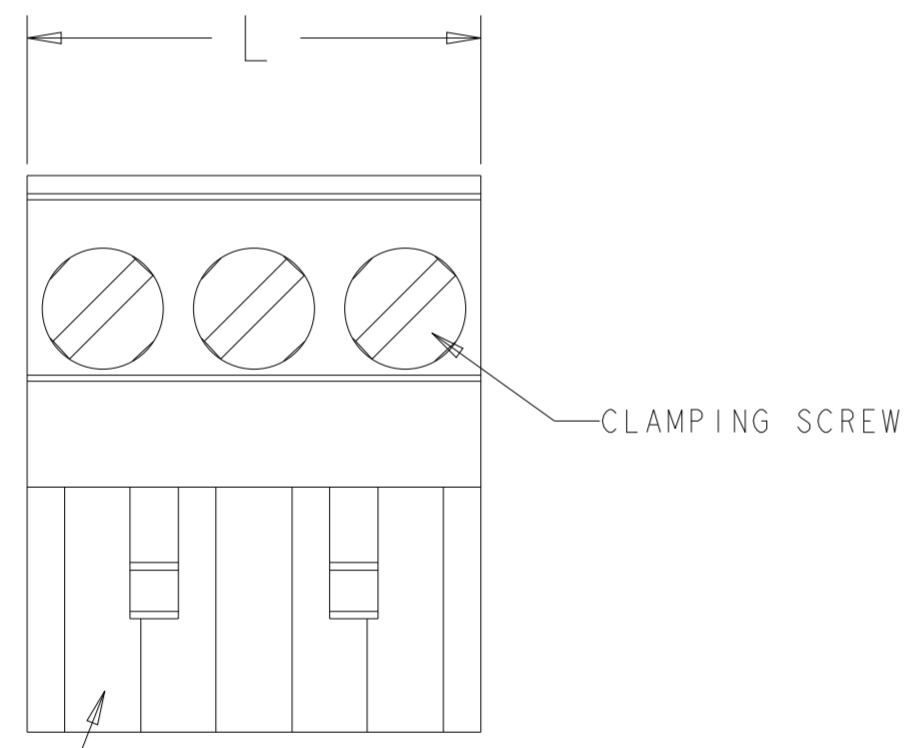
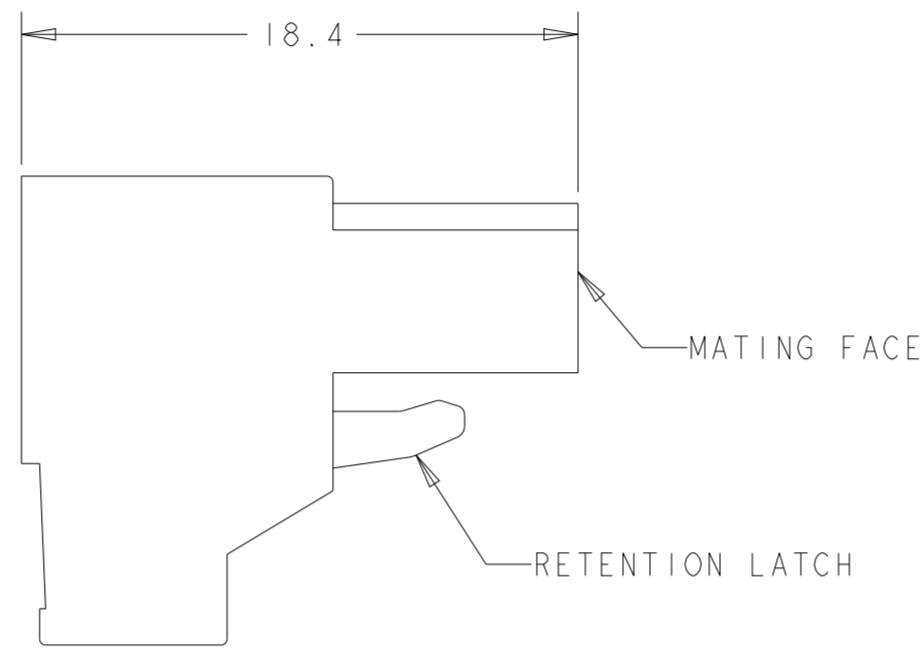
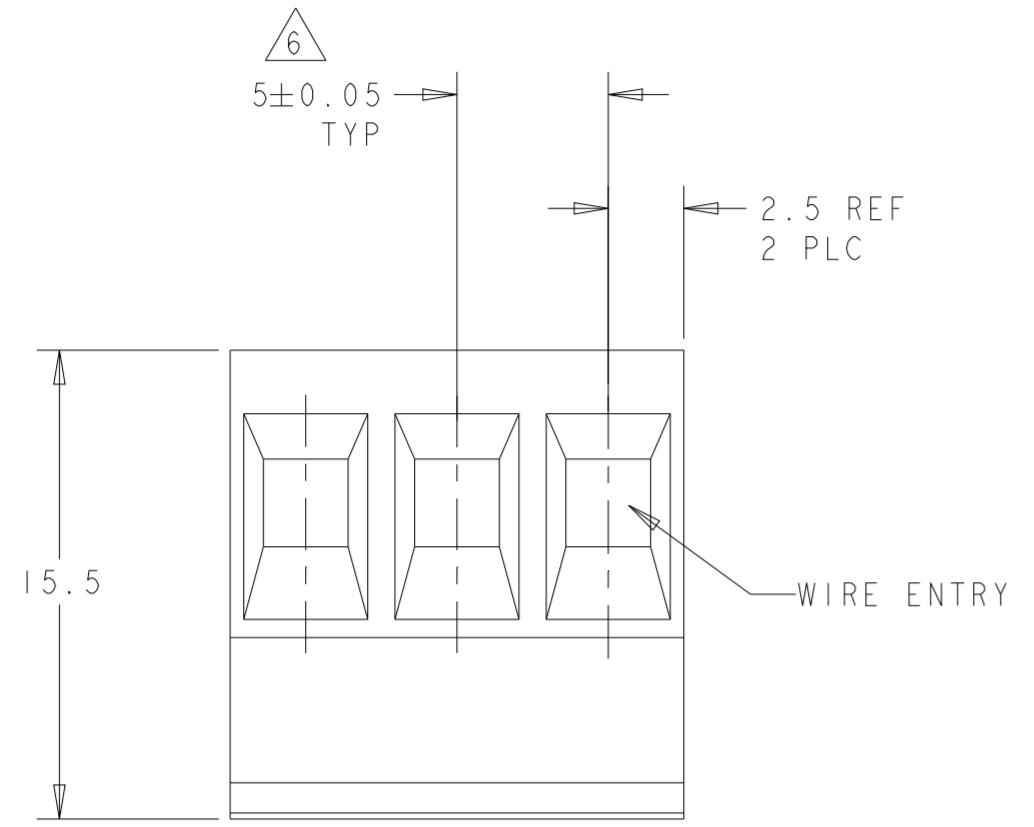

OBSOLETE	TIN	7 9	MARK 4 TO 1	20.00	4	5-796640-4
OBSOLETE	TIN	7 9	MARK 3 TO 1	15.00	3	5-796640-3
OBSOLETE	TIN	7 9	MARK 1 TO 3	15.00	3	5-796640-2
OBSOLETE	TIN	7 9	MARK 1 TO 3	15.00	3	5-796640-1
OBSOLETE	TIN	7 9	MARK 1 TO 4	20.00	4	5-796640-0
OBSOLETE	TIN	7 9	MARK 15 TO 28	70.00	14	4-796640-9
OBSOLETE	TIN	7 9	MARK 13 TO 24	60.00	12	4-796640-8
OBSOLETE	TIN	7 9	MARK 1 TO 14	70.00	14	4-796640-7
OBSOLETE	TIN	8 9	MARK 1 TO 12	60.00	12	4-796640-6
OBSOLETE	TIN	8 9	MARK 1 TO 7	35.00	7	4-796640-5
OBSOLETE	TIN	8 9	MARK 1 TO 5	25.00	5	4-796640-4
OBSOLETE	TIN	8 9	MARK 11 TO 15	25.00	5	4-796640-3
OBSOLETE	TIN	-	DETAIL S	35.00	7	4-796640-2
OBSOLETE	TIN	7 9	MARK 1 TO 3	15.00	3	4-796640-1
OBSOLETE	TIN	-	DETAIL P	20.00	4	4-796640-0
OBSOLETE	TIN	7 9	MARK 1 TO 8	40.00	8	3-796640-9
OBSOLETE	TIN	7 9	MARK 37 TO 54	90.00	18	3-796640-8
OBSOLETE	TIN	7 9	MARK 19 TO 36	90.00	18	3-796640-7
OBSOLETE	TIN	7 9	MARK 1 TO 18	90.00	18	3-796640-6
OBSOLETE	TIN	8 9	MARK 1 TO 10	50.00	10	3-796640-5
OBSOLETE	TIN	8 9	MARK 1 TO 8	40.00	8	3-796640-4
OBSOLETE	TIN	7 9	DETAIL N	30.00	6	3-796640-3
OBSOLETE	TIN	7 9	MARK 1 TO 6	30.00	6	3-796640-2
OBSOLETE	TIN	-	-	125.00	25	2-796640-9
OBSOLETE	TIN	-	-	120.00	24	2-796640-8
OBSOLETE	TIN	-	-	115.00	23	2-796640-7
OBSOLETE	TIN	-	-	110.00	22	2-796640-6
OBSOLETE	TIN	-	-	105.00	21	2-796640-5
OBSOLETE	TIN	-	-	100.00	20	2-796640-4
OBSOLETE	TIN	-	-	95.00	19	2-796640-3
OBSOLETE	TIN	-	-	90.00	18	2-796640-2
OBSOLETE	TIN	-	-	85.00	17	2-796640-1
OBSOLETE	TIN	-	-	80.00	16	1-796640-9
OBSOLETE	TIN	-	-	75.00	15	1-796640-8
OBSOLETE	TIN	-	-	70.00	14	1-796640-7
OBSOLETE	TIN	-	-	65.00	13	1-796640-6
OBSOLETE	TIN	-	-	60.00	12	1-796640-5
OBSOLETE	TIN	-	-	55.00	11	1-796640-4
OBSOLETE	TIN	-	-	50.00	10	1-796640-3
OBSOLETE	TIN	-	-	45.00	9	1-796640-2
OBSOLETE	TIN	-	-	40.00	8	796640-9
OBSOLETE	TIN	-	-	35.00	7	796640-8
OBSOLETE	TIN	-	-	30.00	6	796640-7
OBSOLETE	TIN	-	-	25.00	5	796640-6
OBSOLETE	TIN	-	-	20.00	4	796640-5
OBSOLETE	TIN	-	-	15.00	3	796640-4
OBSOLETE	TIN	-	-	10.00	2	796640-3
OBSOLETE	TIN	-	-	10.00	2	796640-2

TERMINAL PLATING	MARKING	SPECIAL	L	NO OF POSN	PART NUMBER

THIS DRAWING IS A CONTROLLED DOCUMENT.

DWN S. WELDON 18OCT2000  
CHK D. BIEVENOUR 18OCT2000  
APVD D. BIEVENOUR 18OCT2000

**STE** TE Connectivity

NAME: TERMINAL BLOCK, PLUG, STACKING  
5.00mm PITCH

SIZE: A2 CAGE CODE: 00779 DRAWING NO: C-796640

SCALE: 4:1 SHEET: 1 OF 3 REV: F15

P	LTR	DESCRIPTION	DATE	DWN	APVD
-		SEE SHEET 1	-	-	-

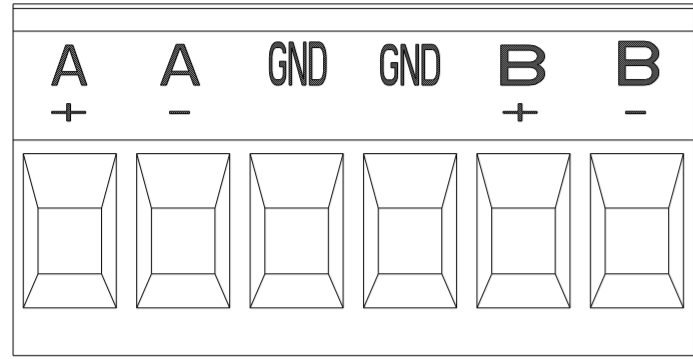

DETAIL N

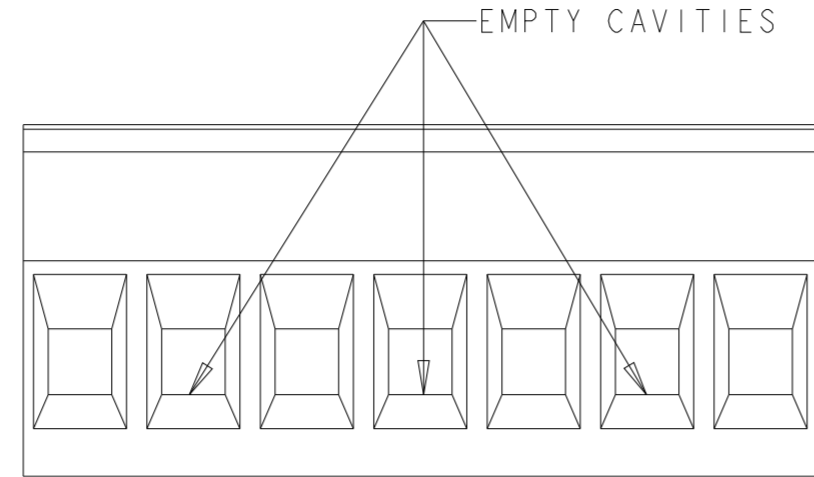

DETAIL S

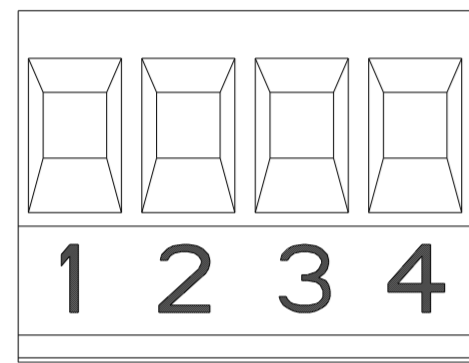

DETAIL P

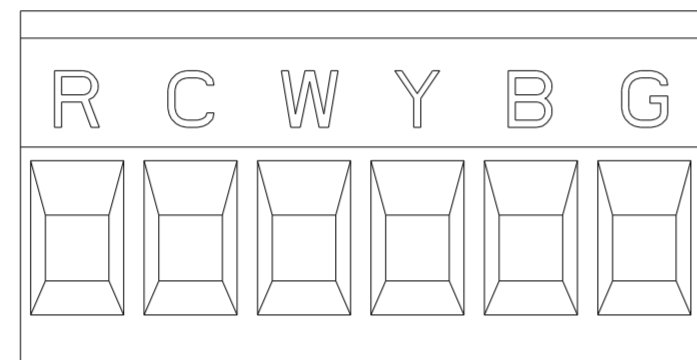

DETAIL T

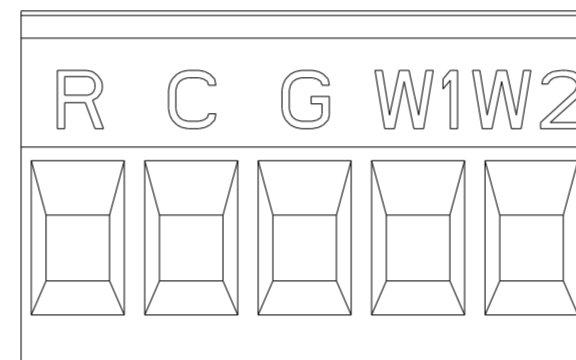

DETAIL Z

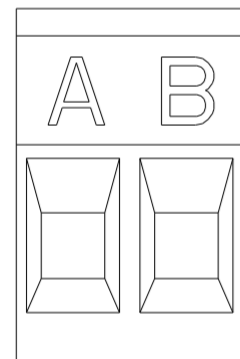

DETAIL U

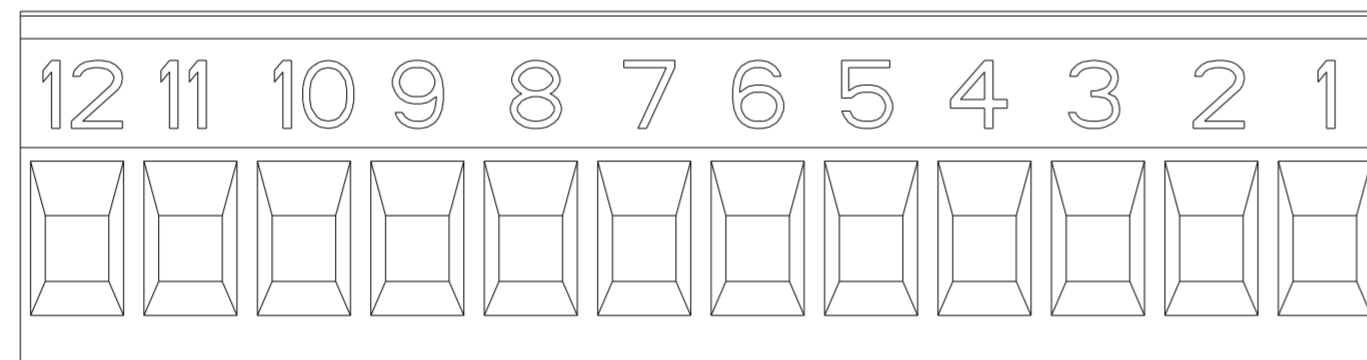

DETAIL V

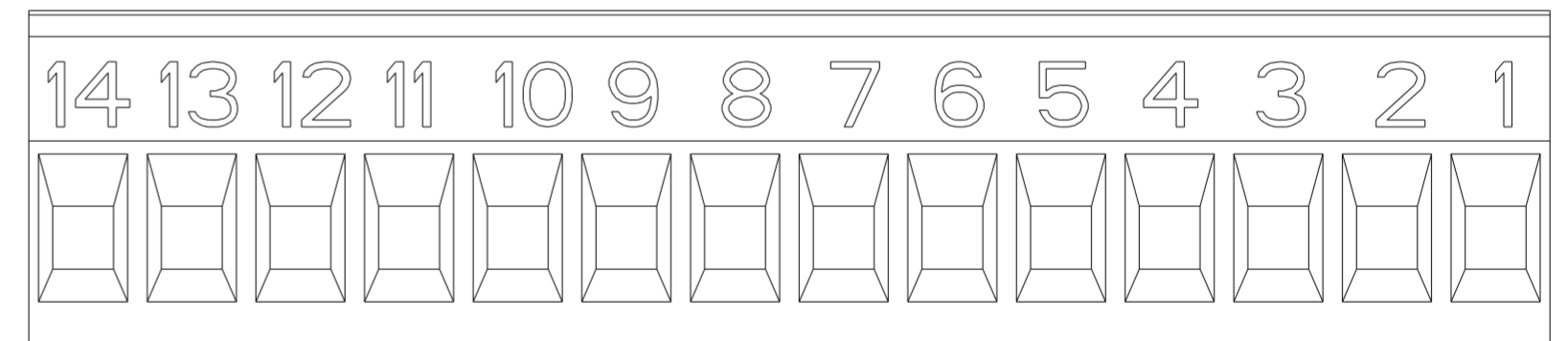

DETAIL X

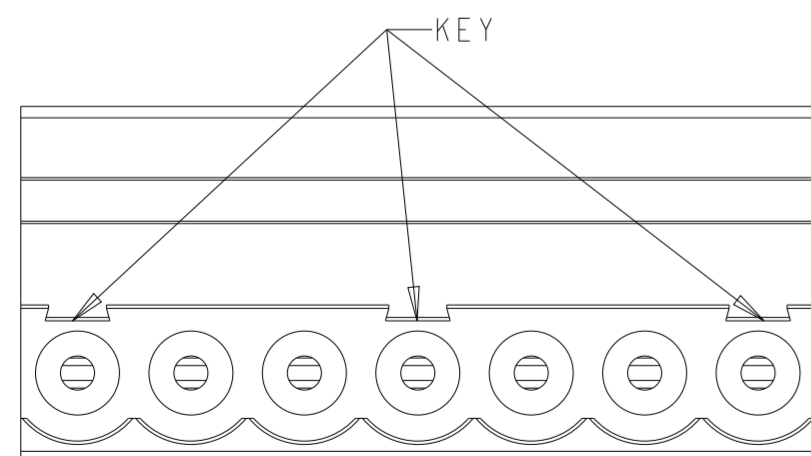

DETAIL W

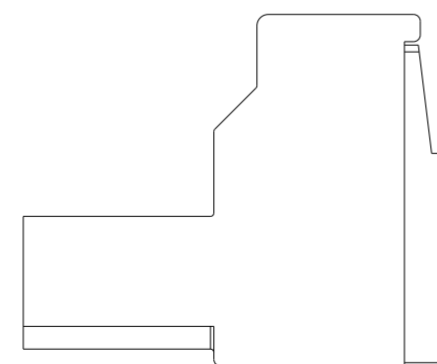

DETAIL Y

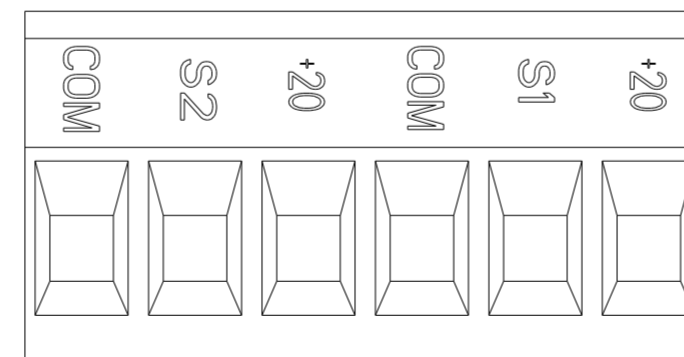

OBSOLETE	TIN	$\begin{matrix} \triangle 7 \\ \triangle 7 \end{matrix}$	DETAIL Z	25.00	5	<del>6-796640-6</del>
	TIN	$\begin{matrix} \triangle 7 \\ \triangle 7 \end{matrix}$	DETAIL Y	30.00	6	<del>6-796640-5</del>
OBSOLETE	TIN	$\begin{matrix} \triangle 7 & \triangle 14 \\ \triangle 7 & \triangle 14 \end{matrix}$	DETAIL X	70.00	14	<del>6-796640-4</del>
	TIN	-	DETAIL W, NO LATCH KEY POSN 1,4,7	35.00	7	<del>6-796640-1</del>
OBSOLETE	TIN	$\begin{matrix} \triangle 7 & \triangle 14 \\ \triangle 7 & \triangle 14 \end{matrix}$	DETAIL V	60.00	12	<del>6-796640-0</del>
	GOLD FLASH	-	-	35.00	7	<del>5-796640-9</del>
OBSOLETE	TIN	$\begin{matrix} \triangle 7 \\ \triangle 7 \end{matrix}$	DETAIL U	10.00	2	<del>5-796640-8</del>
	TIN	$\begin{matrix} \triangle 7 \\ \triangle 7 \end{matrix}$	DETAIL T	30.00	6	<del>5-796640-7</del>
OBSOLETE	TIN	$\begin{matrix} \triangle 7 & \triangle 9 \\ \triangle 7 & \triangle 9 \end{matrix}$	MARK 13 TO 24	60.00	12	<del>5-796640-6</del>
	TIN	$\begin{matrix} \triangle 7 & \triangle 9 \\ \triangle 7 & \triangle 9 \end{matrix}$	MARK 25 TO 38	70.00	14	<del>5-796640-5</del>
	TERMINAL PLATING	MARKING	SPECIAL	L	NO OF POSN	PART NUMBER

THIS DRAWING IS A CONTROLLED DOCUMENT.

DIMENSIONS: mm	TOLERANCES UNLESS OTHERWISE SPECIFIED: 0 PLC ± 1 PLC ±0.3 2 PLC ±0.25 3 PLC ± 4 PLC ± ANGLES ±2 FINISH	DWN S. WELDON 18OCT2000 CHK D. BIEVENOUR 18OCT2000 APVD D. BIEVENOUR 18OCT2000	TE Connectivity NAME: TERMINAL BLOCK, PLUG, STACKING 5.00mm PITCH
MATERIAL SEE NOTES	SEE NOTES	PRODUCT SPEC APPLICATION SPEC WEIGHT	

CUSTOMER DRAWING

REVISIONS

P	LTR	DESCRIPTION	DATE	DWN	APVD
	-	SEE SHEET 1	-	-	-

NOTES:

- 1. MATERIALS AND FINISH:  
HOUSING: PA 6-6, UL 94-V0, COLOR: GREEN.  
CLAMP: BRASS, NICKEL PLATED.  
DOUBLE SIDE CONTACT SPRING: PHOSPHOR BRONZE, PLATING: SEE TABLE.  
CLAMPING SCREW: M3, BRASS, NICKEL PLATED.
- 2. END-TO-END STACKABLE WITHOUT LOSS OF CENTERLINE SPACING.
- 3. MECHANICAL  
WIRE STRIPPING LENGTH : 6.0-7.5 mm  
RECOMMENDED TIGHTENING TORQUE FOR SCREW : 0.5 Nm.
- 4. ELECTRICAL  
WIRE RANGE : 12-30 AWG  
MAX. VOLTAGE : 300 V  
MAX CURRENT : 15 A  
CONTACT RESISTANCE : <15 m Ohm  
INSULATION RESISTANCE : >1000 M Ohm (500V DC)
- 5. RECOGNIZED UNDER THE COMPONENT PROGRAM OF UNDERWRITERS LABORATORIES INC. FILE NO E60677.
- 6. NOT CUMULATIVE TOLERANCE
- 7. INK MARKING: BLACK COLOR.
- 8. INK MARKING: WHITE COLOR.
- 9. NUMERICAL SEQUENCE: FROM LEFT TO RIGHT, WIRE ENTRY SIDE.
- 10. RETENTION LATCHES REMOVED
- 11. BUCHANAN LOGO TO APPEAR ON HOUSING, LOCATION OPTIONAL WHERE SPACE PERMITS.
- 12. WIRE ENTRY CLOSED.
- 13. PRELIMINARY - NOT FOR PRODUCTION.
- 14. NUMERICAL SEQUENCE: FROM RIGHT TO LEFT, WIRE ENTRY SIDE.
- 15. OPERATING TEMPERATURE RANGE: -40°C TO +105°C

THIS DRAWING IS A CONTROLLED DOCUMENT.		DWN S. WELDON 18OCT2000	 TE Connectivity	
DIMENSIONS: mm		CHK D. BIEVENOUR 18OCT2000		
TOLERANCES UNLESS OTHERWISE SPECIFIED:		APVD D. BIEVENOUR 18OCT2000	NAME TERMINAL BLOCK, PLUG, STACKING 5.00mm PITCH	
0 PLC ± 1 PLC ±0.3 2 PLC ±0.25 3 PLC ± 4 PLC ±		PRODUCT SPEC -	SIZE A2	
ANGLES ±2		APPLICATION SPEC -	CAGE CODE 00779	DRAWING NO C-796640
MATERIAL SEE NOTES	FINISH SEE NOTES	WEIGHT -	RESTRICTED TO -	
CUSTOMER DRAWING		SCALE 4:1	SHEET 3 OF 3	REV F15